

# High Side Current Sense with Comparators and a 400mV Reference

## DESCRIPTION

Demonstration circuit 2193A features the [LT<sup>®</sup>6119](#), a high side current sense amplifier with comparators and a 400mV reference.

The demo board circuit amplifies the voltage across an onboard current sense resistor, to provide a precision unipolar voltage output that is proportional to the sensed current. The board has two onboard comparators with latching outputs and an integrated 400mV reference that sets the threshold for the comparators. There are two versions of the board, A and B. The version determines the available comparator inputs. The DC2261A-A (LT6119-1) has an inverting and a noninverting comparator input available while the DC2261A-B (LT6119-2) has two inverting inputs

available. The demonstration board includes circuitry to guarantee that the comparator resets on power up. The current sense gain and current fault limits are set by on board resistors. The default gain is set at 10V/A and the comparators are set to trip at current thresholds of 50mA and 300mA.

The key performance specifications are listed in the table below.

**Design files for this circuit board are available at <http://www.linear.com/demo/DC2261A>**

LT, LT, LTC, LTM, Linear Technology and the Linear logo are registered trademarks of Linear Technology Corporation. All other trademarks are the property of their respective owners.

## PERFORMANCE SUMMARY Specifications are at T<sub>A</sub> = 25°C

SYMBOL	PARAMETER	CONDITIONS	MIN	TYP	MAX	UNITS
V <sub>IN</sub>	Input Supply Range		2.7		60	V
V <sub>OUTA</sub>	Measured Output Signal	I <sub>LOAD</sub> = 100mA		1		V
I <sub>LOAD</sub>	Output Load Current Range	Thermal Limit of R <sub>SENSE</sub>			3	A
I <sub>Q</sub>	IN Quiescent Current	V <sub>IN</sub> = 12V		600		μA
I <sub>THR1</sub>	Comparator1 Threshold	V <sub>OUTA</sub> = 3V		300		mA
I <sub>THR2</sub>	Comparator2 Threshold	V <sub>OUTA</sub> = 0.5V		50		mA

## OPERATING PRINCIPLES

The LT6119 operates by amplifying the voltage drop across a sense resistor that is in series with the load. The sense inputs of the amplifier differentially measure the sense resistor voltage drop to control an internal variable current source that allows translation of the input voltage level to a level referenced to the GND. The circuit gain is set by the ratio of the output resistor to the input resistor. The comparator thresholds are set by the internal reference and the current trip points are set by dividing the output

resistance into a network of three resistors. The RC filter connected to the latch enable (LE) pin guarantee that the latch enable pin is held low long enough on start-up to reset the comparator output on power on.

The DC2261A is shipped with a 100mΩ sense resistor. The amplifier gain is configured for 100V/V, providing an overall circuit gain of 10V/A. The current fault thresholds are set at 50mA and 300mA.

# DEMO MANUAL DC2261A

## BLOCK DIAGRAM

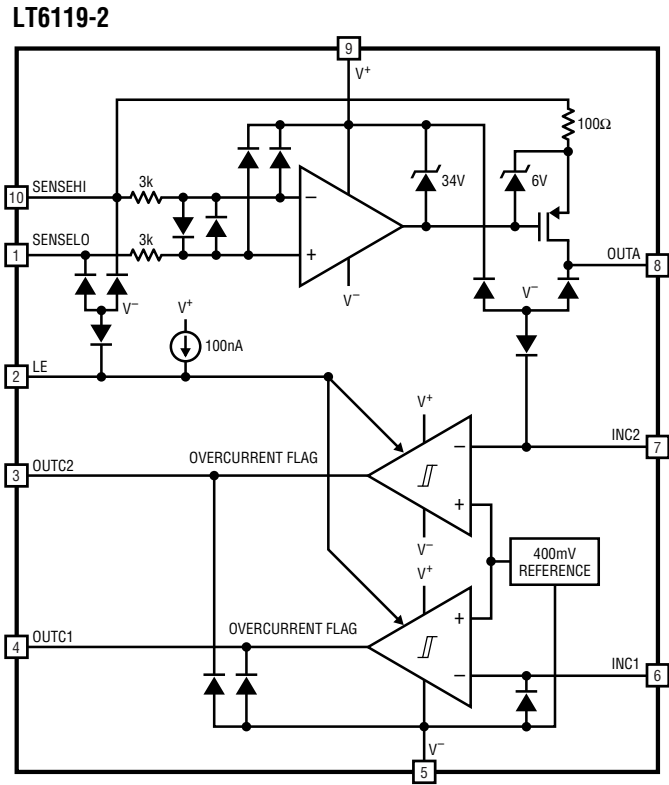
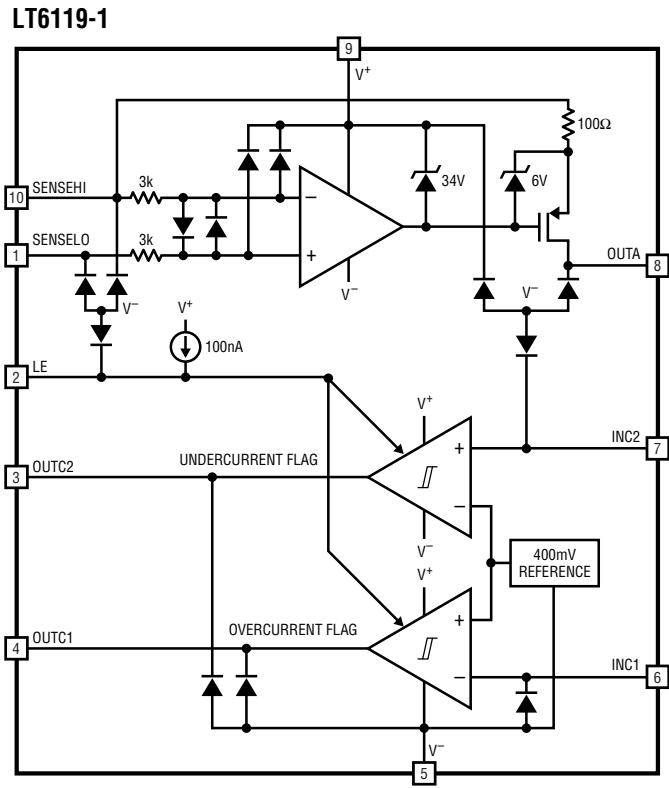



## CURRENT SENSE GAIN

The gain of the LT6119 current sense amplifier is set by the ratio of  $R_{OUT}$  and  $R_{IN}$  resistors. In the demo circuit this means that the gain is set by the ratio of  $(R_{OUT})/R4$ , where  $R_{OUT} = (R7 + R10 + R11) \parallel R8(OPT)$ . The default values are  $R7 = 2k$ ,  $R10 = 6.65k$ ,  $R11 = 1.33k$ , and  $R8$  is not installed. This provides a gain of  $9.98k/100$ . By installing the optional resistor,  $R8$ , the gain can be reduced. The gain error is primarily set by the precision of the resistors used:

The provided resistors are a 1% tolerance which will dominate the gain error. To reduce system gain error, the resistors can be replaced with 0.1% resistors.

### Jumper Summary

JP1: The Logic supply jumper has two settings.

- $V^+$ : the comparator output is tied to the  $V^+$  supply
- EXT: the comparator output is tied to an external supply on the VLOGIC Turret

### Optional Settings

1. To power the LT6119 from a supply separate from the load, remove  $R1$  and connect the power supply to the  $V^+$  turret.
2. There are a number of optional components that allow the DC2193 to be tailored to a specific application:
  - A) To free comparator inputs INC1 and INC2 for other use, remove  $R7$ ,  $R10$  and  $R11$  and install  $R8$ . Connect LE turret as required.
  - B) To add filtering to the amplifier output, install  $C3$ .
  - C) If driving the LE turret from an external source, pressing the reset button,  $SW1$  will short the signal. A resistor can be added at  $R13$  to help isolate the external signal.

**SCHEMATIC DIAGRAM**

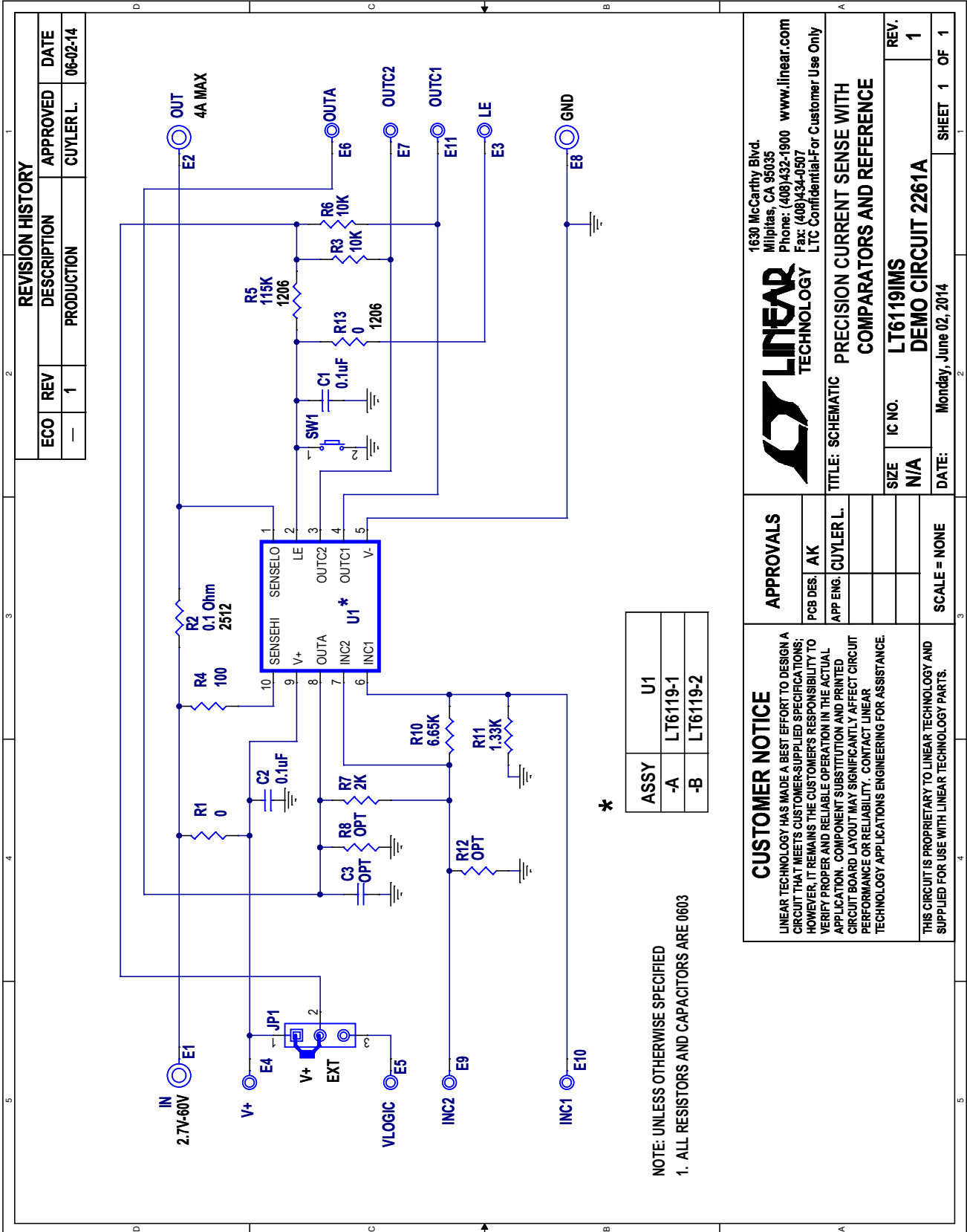

dc2261af

# DEMO MANUAL DC2261A

---

## DEMONSTRATION BOARD IMPORTANT NOTICE

Linear Technology Corporation (LTC) provides the enclosed product(s) under the following **AS IS** conditions:

This demonstration board (DEMO BOARD) kit being sold or provided by Linear Technology is intended for use for **ENGINEERING DEVELOPMENT OR EVALUATION PURPOSES ONLY** and is not provided by LTC for commercial use. As such, the DEMO BOARD herein may not be complete in terms of required design-, marketing-, and/or manufacturing-related protective considerations, including but not limited to product safety measures typically found in finished commercial goods. As a prototype, this product does not fall within the scope of the European Union directive on electromagnetic compatibility and therefore may or may not meet the technical requirements of the directive, or other regulations.

If this evaluation kit does not meet the specifications recited in the DEMO BOARD manual the kit may be returned within 30 days from the date of delivery for a full refund. **THE FOREGOING WARRANTY IS THE EXCLUSIVE WARRANTY MADE BY THE SELLER TO BUYER AND IS IN LIEU OF ALL OTHER WARRANTIES, EXPRESSED, IMPLIED, OR STATUTORY, INCLUDING ANY WARRANTY OF MERCHANTABILITY OR FITNESS FOR ANY PARTICULAR PURPOSE. EXCEPT TO THE EXTENT OF THIS INDEMNITY, NEITHER PARTY SHALL BE LIABLE TO THE OTHER FOR ANY INDIRECT, SPECIAL, INCIDENTAL, OR CONSEQUENTIAL DAMAGES.**

The user assumes all responsibility and liability for proper and safe handling of the goods. Further, the user releases LTC from all claims arising from the handling or use of the goods. Due to the open construction of the product, it is the user's responsibility to take any and all appropriate precautions with regard to electrostatic discharge. Also be aware that the products herein may not be regulatory compliant or agency certified (FCC, UL, CE, etc.).

No License is granted under any patent right or other intellectual property whatsoever. **LTC assumes no liability for applications assistance, customer product design, software performance, or infringement of patents or any other intellectual property rights of any kind.**

LTC currently services a variety of customers for products around the world, and therefore this transaction **is not exclusive**.

**Please read the DEMO BOARD manual prior to handling the product.** Persons handling this product must have electronics training and observe good laboratory practice standards. **Common sense is encouraged.**

This notice contains important safety information about temperatures and voltages. For further safety concerns, please contact a LTC application engineer.

Mailing Address:

Linear Technology  
1630 McCarthy Blvd.  
Milpitas, CA 95035

Copyright © 2004, Linear Technology Corporation

## X-ON Electronics

Largest Supplier of Electrical and Electronic Components

*Click to view similar products for [Amplifier IC Development Tools](#) category:*

*Click to view products by [Analog Devices](#) manufacturer:*

Other Similar products are found below :

[EVAL-ADCMP566BCPZ](#) [EVAL-ADCMP606BKSZ](#) [AD8013AR-14-EBZ](#) [AD8033AKS-EBZ](#) [AD8044AR-EBZ](#) [AD8225-EVALZ](#)  
[ADA4859-3ACP-EBZ](#) [ADA4862-3YR-EBZ](#) [DEM-OPA-SO-2B](#) [AD744JR-EBZ](#) [AD8023AR-EBZ](#) [AD8030ARJ-EBZ](#) [AD8040ARU-EBZ](#)  
[AD8073JR-EBZ](#) [AD813AR-14-EBZ](#) [AD848JR-EBZ](#) [ADA4858-3ACP-EBZ](#) [ADA4922-1ACP-EBZ](#) [551600075-001/NOPB](#) [DEM-OPA-SO-](#)  
[2E](#) [THS7374EVM](#) [EVAL-ADCMP553BRMZ](#) [EVAL-ADCMP608BKSZ](#) [MIOP 42109](#) [EVAL-ADCMP609BRMZ](#) [MAX9928EVKIT+](#)  
[MAX9636EVKIT+](#) [MAX9611EVKIT](#) [MAX9937EVKIT+](#) [MAX9934TEVKIT+](#) [MAX44290EVKIT#](#) [MAX2644EVKIT](#) [MAX4073EVKIT+](#)  
[DEM-OPA-SO-2C](#) [MAX2643EVKIT](#) [ISL28158EVAL1Z](#) [MAX40003EVKIT#](#) [MAX2473EVKIT](#) [MAX2472EVKIT](#) [MAX4223EVKIT](#)  
[MAX9700BEVKIT](#) [MADL-011014-001SMB](#) [DC1685A](#) [DEM-OPA-SO-2D](#) [MAX2670EVKIT#](#) [DEM-OPA-SO-1E](#) [AD8137YCP-EBZ](#)  
[EVAL-ADA4523-1ARMZ](#) [MAX44242EVKIT#](#) [EVAL-LT5401\\_32FDAZ](#)