

**LT3091EDE**
**-36V, 1.5A Negative Linear Regulator  
 with Programmable Current Limit**
**DESCRIPTION**

Demonstration circuit DC2276A is a 1.5A low dropout negative linear regulator featuring the [LT<sup>®</sup>3091](#). This device is designed for applications requiring negative output voltage, high current without a heat sink, output adjustability to zero and low dropout voltage.

The LT3091 features fast transient response, high PSRR and output noise as low as  $18\mu\text{V}_{\text{RMS}}$ . The LT3091 generates a wide output voltage range (0V to -32V) while maintaining unity gain operation. This yields virtually constant bandwidth, load regulation, PSRR and noise, independent of the programmed output voltage.

The LT3091 supplies 1.5A at a typical dropout voltage of 300mV. Operating quiescent current is nominally 1.2mA and drops to  $\ll 1\mu\text{A}$  in shutdown. A single resistor adjusts the LT3091's precision programmable current limit. The LT3091's positive or negative current monitor either

sources a current (0.25mA/A) or sinks a current (0.5mA/A) proportional to output current.

Built-in protection includes reverse output protection, internal current limit with foldback and thermal shutdown with hysteresis.

DC2276A uses the LT3091EDE which is a 14-lead (4mm x 3mm) plastic DFN package with an exposed pad on the bottom side of the IC for better thermal performance. These features make DC2276A an ideal circuit for surface-mount power supplies, rugged industrial power supplies, low output voltage supplies and as a post regulator for switching supplies.

**Design files for this circuit board are available at <http://www.linear.com/demo/DC2276A>**

LT, LT, LTC, LTM, Linear Technology and the Linear logo are registered trademarks of Linear Technology Corporation. All other trademarks are the property of their respective owners.

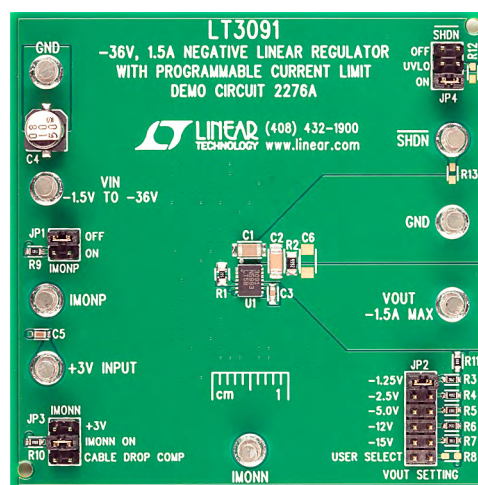
**BOARD PHOTO**

# DEMO MANUAL DC2276A

## PERFORMANCE SUMMARY Specifications are at $T_A = 25^\circ\text{C}$

CONDITIONS	$I_{OUT}$	$V_{IN}$ (V)			$V_{OUT}$ (V)		
		MIN*	TYP	MAX	MIN	TYP	MAX
Shunt at -1.25V for JP1	-10mA	-36.0		-1.55	-1.30	-1.25	-1.20
	-1.5A	-2.75		-1.55	-1.30	-1.25	-1.20
Shunt at -2.5V for JP1	-10mA	-36.0		-2.80	-2.6	-2.5	-2.4
	-1.5A	-4.0		-2.80	-2.6	-2.5	-2.4
Shunt at -5.0V for JP1	-10mA	-36.0		-5.30	-5.2	-5.0	-4.8
	-1.5A	-6.50		-5.30	-5.2	-5.0	-4.8
Shunt at -12V for JP1	-10mA	-36.0		-12.3	-12.5	-12.0	-11.5
	-1.5A	-13.5		-12.3	-12.5	-12.0	-11.5
Shunt at -15V for JP1	-10mA	-36.0		-15.3	-15.6	-15.0	-14.4
	-1.5A	-16.5		-15.3	-15.6	-15.0	-14.4

\* The minimum input voltage for -1.5A load current is set by the 50°C temperature rise of LT3091 on the demo circuit without forced-air cooling. Lower input voltage can be reached if larger copper area or forced-air cooling is applied. The output current is also limited by the differential voltage of input and output voltage, please refer the data sheet for details.

## QUICK START PROCEDURE

DC2276A is easy to set up to evaluate the performance of the LT3091. Refer to Figure 1 for proper measurement equipment setup and follow the procedure below:

NOTE: When measuring the input or output voltage ripple, care must be taken to avoid a long ground lead on the oscilloscope probe. Measure the input or output voltage ripple by touching the probe tip directly across the terminals of the input or output capacitors. See Figure 2 for proper scope probe technique.

1. Use JP2 to set the desired output voltage.
2. Put JP4 on ON position.
3. With power off, connect the input power supply to  $V_{IN}$  and GND.

4. Turn on the power at the  $V_{IN}$ .

NOTE: Make sure that the  $V_{IN}$  voltage does not exceed  $-36V$ .

5. Check for the proper output voltages:

NOTE: If there is no output, temporarily dis-connect the load to make sure that the load is not set too high or is shorted.

6. Once the proper output voltages are established, adjust the loads within the operating range and observe the output voltage regulation, efficiency and other parameters.

NOTE: Make sure that the power dissipation is limited below the thermal limit.

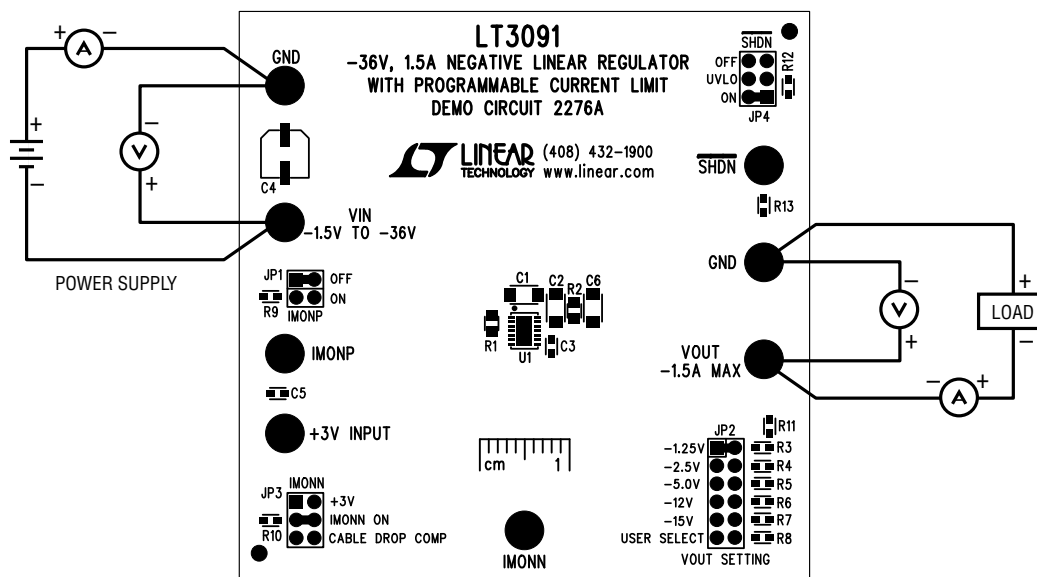

Figure 1. Test Procedure Setup for DC2276A

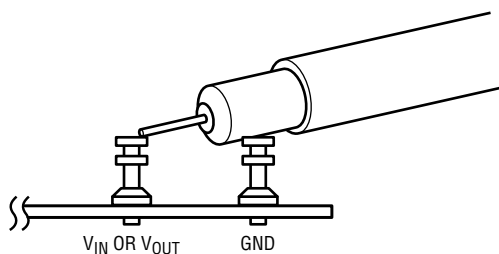

Figure 2. Measuring Input or Output Ripple

## POSITIVE OR NEGATIVE CURRENT MONITOR AND CABLE DROP COMPENSATION CONFIGURATION

There are both positive and negative current monitors on the LT3091. The configurations for these two monitors are different. Please check following table for proper configuration.

When the positive current monitor is in use, JP1 needs to be configured on ON position and JP3 needs to be configured on +3V position. Meantime, a +3V external power supply needs to be connected to +3V INPUT turret.

When the negative current monitor is in use, JP1 needs to be configured on OFF position and JP3 needs to be configured on IMONN ON position. There is no external power supply needed.

Demo Circuit 2276A also can be configured to evaluate the cable drop compensation on the LT3091. Note that cable drop compensation is only using negative current monitor configuration. JP1, JP3 and R11 shall be configured. JP1 needs to be configured on OFF position. JP3 needs to be configured on CABLE DROP COMP position. R11 needs to be replaced by a calculated value which has the following relationship with the total output cable impedance (RCBL) below. R11 and RCBL are both in  $\Omega$ :  $R11 = RCBL \cdot 2 k$ .

	JP1 (IMONP)	JP3 (IMONN)	R11( $\Omega$ )
Positive Current Monitor	ON	+3V	0
Negative Current Monitor	OFF	IMONN ON	0
Cable Drop Compensation	OFF	CABLE DROP COMP	$RCBL(\Omega) \cdot 2 k$

## THERMAL IMAGE

An example thermal image shows the temperature distribution on the PC board. The test is done in still air at room temperature with 2.25W power dissipation in

the LT3091 IC. This gives an IC case-to-ambient thermal resistance of  $\theta_{CA} = 22^{\circ}\text{C}/\text{W}$  on the demo circuit. The IC, at its highest point, reaches  $75^{\circ}\text{C}$ , at  $-2.75\text{V}_{\text{IN}}$ ,  $-1.25\text{V}_{\text{OUT}}$  and 1.5A load current.

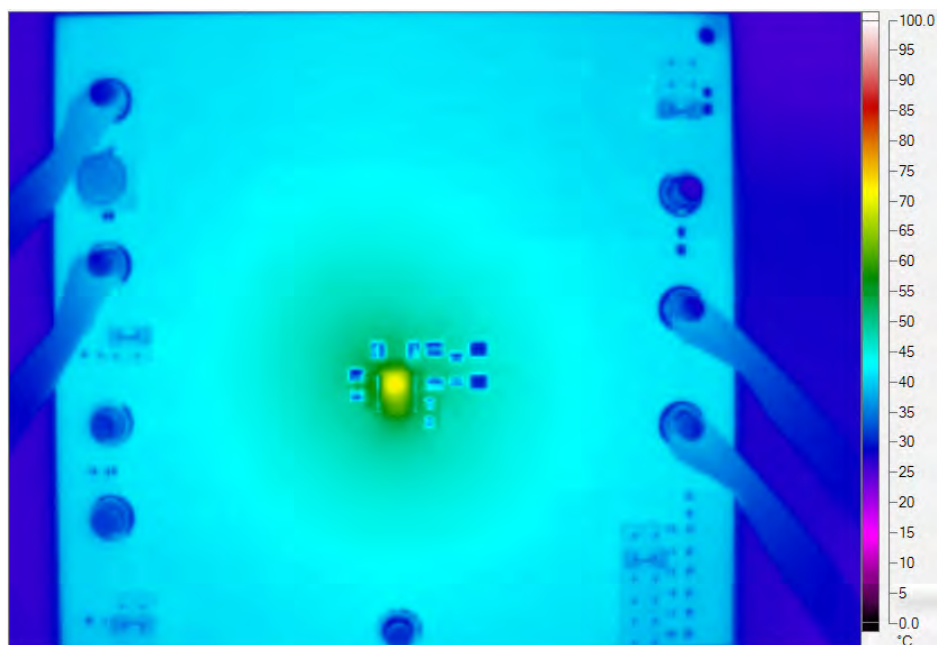

Figure 3. Temperature Rise at 2.25W Dissipation ( $V_{\text{IN}} = -2.75\text{V}$ ,  $V_{\text{OUT}} = -1.25\text{V}$ ,  $I_{\text{OUT}} = -1.5\text{A}$ )

# DEMO MANUAL DC2276A

## PARTS LIST

ITEM	QTY	REFERENCE	PART DESCRIPTION	MANUFACTURER/PART NUMBER
<b>Required Circuit Components</b>				
1	2	C1,C2	CAP., X5R, 10 $\mu$ F, 50V, 10%, 1206	MURATA, GRM31CR61H106KA12L
2	1	C3	CAP., X7R, 0.1 $\mu$ F, 25V, 10%, 0603	MURATA, GRM188R71E104KA01D
3	1	C4	CAP., ALUM, 10 $\mu$ F, 50V, 20%	SUN ELECT, 50CE10BSS
4	1	C5	CAP., X7R, 1 $\mu$ F, 10V, 10%, 0603	MURATA, GRM188R71A105KA61D
5	1	R1	RES., CHIP, 5.1k, 1/10W, 5%, 0603	VISHAY, CRCW06035K10JNEA
6	1	R2	RES., CHIP, 49.9k, 1/8W, 1%, 0805	VISHAY, CRCW080549K9FKEA
7	1	R3	RES., CHIP, 24.9k, 1/10W, 1%, 0603	VISHAY, CRCW060324K9FKEA
8	1	R4	RES., CHIP, 49.9k, 1/10W, 1%, 0603	VISHAY, CRCW060349K9FKEA
9	1	R5	RES., CHIP, 100k, 1/10W, 1%, 0603	VISHAY, CRCW0603100KFKEA
10	1	R6	RES., CHIP, 243k, 1/10W, 1%, 0603	VISHAY, CRCW0603243KFKEA
11	1	R7	RES., CHIP, 301k, 1/10W, 1%, 0603	VISHAY, CRCW0603301KFKEA
12	1	R9	RES., CHIP, 1.58k, 1/10W, 1%, 0603	VISHAY, CRCW06031K58FKEA
13	1	R10	RES., CHIP, 806, 1/10W, 1%, 0603	VISHAY, CRCW0603806RFKEA
14	1	R11	RES., CHIP, 0, 1/10W, 0603	VISHAY, CRCW06030000Z0EA
15	1	U1	I.C., REGULATOR, DFN14	LINEAR TECH, LT3091EDE#PBF
<b>Additional Demo Board Circuit Components</b>				
16	0	C5 (OPT)	CAP., OPTION, 1206	
17	0	R8, R12, R13 (OPT)	RES., OPTION, 0603	
<b>Hardware: For Demo Board Only</b>				
18	8	E1-E8	TESTPOINT, TURRET, .094" PBF	MILL-MAX, 2501-2-00-80-00-00-07-0
19	1	JP1	HEADER 2x2 PIN 0.079 DOUBLE ROW	WURTH ELEKTRONIK, 62000421121
20	1	JP2	HEADER 6x2 PIN 0.079 DOUBLE ROW	SAMTEC, TMM-106-02-L-D
21	2	JP3-JP4	HEADER 3x2 PIN 0.079 DOUBLE ROW	WURTH ELEKTRONIK, 62000621121
22	4	XJP1-XJP4	SHUNT, 0.079" CENTER	WURTH ELEKTRONIK, 60800213421

**SCHEMATIC DIAGRAM**

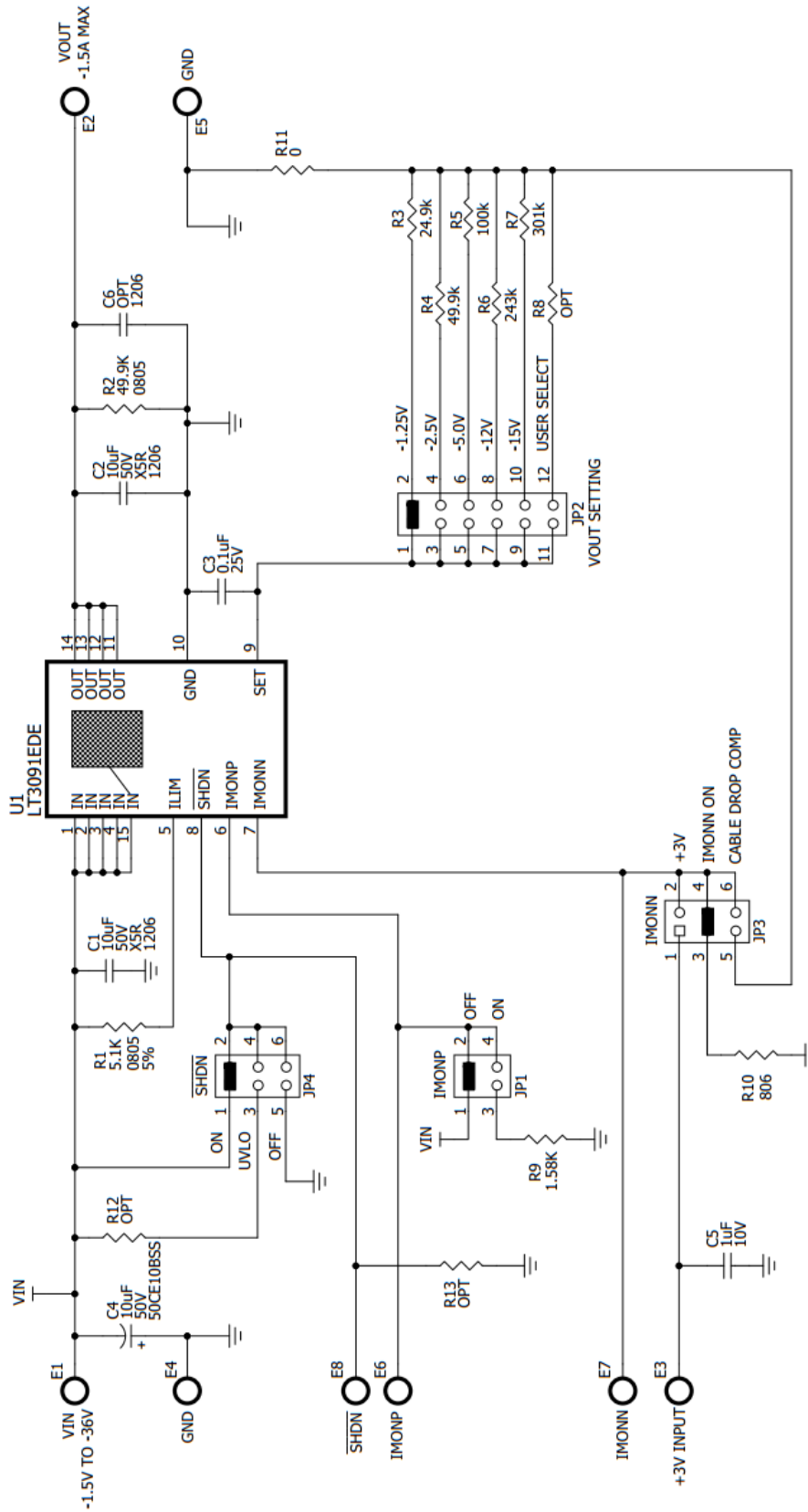

**NOTE: UNLESS OTHERWISE SPECIFIED**

1. ALL RESISTORS ARE 0603, 1%.  
ALL CAPACITORS ARE 0603

# DEMO MANUAL DC2276A

---

## DEMONSTRATION BOARD IMPORTANT NOTICE

Linear Technology Corporation (LTC) provides the enclosed product(s) under the following **AS IS** conditions:

This demonstration board (DEMO BOARD) kit being sold or provided by Linear Technology is intended for use for **ENGINEERING DEVELOPMENT OR EVALUATION PURPOSES ONLY** and is not provided by LTC for commercial use. As such, the DEMO BOARD herein may not be complete in terms of required design-, marketing-, and/or manufacturing-related protective considerations, including but not limited to product safety measures typically found in finished commercial goods. As a prototype, this product does not fall within the scope of the European Union directive on electromagnetic compatibility and therefore may or may not meet the technical requirements of the directive, or other regulations.

If this evaluation kit does not meet the specifications recited in the DEMO BOARD manual the kit may be returned within 30 days from the date of delivery for a full refund. **THE FOREGOING WARRANTY IS THE EXCLUSIVE WARRANTY MADE BY THE SELLER TO BUYER AND IS IN LIEU OF ALL OTHER WARRANTIES, EXPRESSED, IMPLIED, OR STATUTORY, INCLUDING ANY WARRANTY OF MERCHANTABILITY OR FITNESS FOR ANY PARTICULAR PURPOSE. EXCEPT TO THE EXTENT OF THIS INDEMNITY, NEITHER PARTY SHALL BE LIABLE TO THE OTHER FOR ANY INDIRECT, SPECIAL, INCIDENTAL, OR CONSEQUENTIAL DAMAGES.**

The user assumes all responsibility and liability for proper and safe handling of the goods. Further, the user releases LTC from all claims arising from the handling or use of the goods. Due to the open construction of the product, it is the user's responsibility to take any and all appropriate precautions with regard to electrostatic discharge. Also be aware that the products herein may not be regulatory compliant or agency certified (FCC, UL, CE, etc.).

No License is granted under any patent right or other intellectual property whatsoever. **LTC assumes no liability for applications assistance, customer product design, software performance, or infringement of patents or any other intellectual property rights of any kind.**

LTC currently services a variety of customers for products around the world, and therefore this transaction **is not exclusive**.

**Please read the DEMO BOARD manual prior to handling the product.** Persons handling this product must have electronics training and observe good laboratory practice standards. **Common sense is encouraged.**

This notice contains important safety information about temperatures and voltages. For further safety concerns, please contact a LTC application engineer.

Mailing Address:

Linear Technology  
1630 McCarthy Blvd.  
Milpitas, CA 95035

Copyright © 2004, Linear Technology Corporation



## X-ON Electronics

Largest Supplier of Electrical and Electronic Components

*Click to view similar products for [Power Management IC Development Tools](#) category:*

*Click to view products by [Analog Devices](#) manufacturer:*

Other Similar products are found below :

[EVAL-ADM1168LQEBZ](#) [EVB-EP5348UI](#) [MIC23451-AAAYFL EV](#) [MIC5281YMME EV](#) [DA9063-EVAL](#) [ADP122-3.3-EVALZ](#) [ADP130-0.8-EVALZ](#) [ADP130-1.2-EVALZ](#) [ADP130-1.5-EVALZ](#) [ADP130-1.8-EVALZ](#) [ADP1714-3.3-EVALZ](#) [ADP1716-2.5-EVALZ](#) [ADP1740-1.5-EVALZ](#) [ADP1752-1.5-EVALZ](#) [ADP1828LC-EVALZ](#) [ADP1870-0.3-EVALZ](#) [ADP1871-0.6-EVALZ](#) [ADP1873-0.6-EVALZ](#) [ADP1874-0.3-EVALZ](#) [ADP1882-1.0-EVALZ](#) [ADP199CB-EVALZ](#) [ADP2102-1.25-EVALZ](#) [ADP2102-1.875EVALZ](#) [ADP2102-1.8-EVALZ](#) [ADP2102-2-EVALZ](#) [ADP2102-3-EVALZ](#) [ADP2102-4-EVALZ](#) [ADP2106-1.8-EVALZ](#) [ADP2147CB-110EVALZ](#) [AS3606-DB](#) [BQ24010EVM](#) [BQ24075TEVM](#) [BQ24155EVM](#) [BQ24157EVM-697](#) [BQ24160EVM-742](#) [BQ24296MEVM-655](#) [BQ25010EVM](#) [BQ3055EVM](#) [NCV891330PD50GEVB](#) [ISLUSBI2CKIT1Z](#) [LM2744EVAL](#) [LM2854EVAL](#) [LM3658SD-AEV/NOPB](#) [LM3658SDEV/NOPB](#) [LM3691TL-1.8EV/NOPB](#) [LM4510SDEV/NOPB](#) [LM5033SD-EVAL](#) [LP38512TS-1.8EV](#) [EVAL-ADM1186-1MBZ](#) [EVAL-ADM1186-2MBZ](#)