

LTC5576

3GHz to 8GHz High Linearity Active Upconverting Mixer

DESCRIPTION

Demonstration circuit 2322A is designed for evaluation of the LTC[®]5576 active upconverting mixer with very wide input bandwidth and low distortion. Its OUT port is optimized for 4GHz to 6GHz applications, but is easily retuned for output frequencies as low as 3GHz, or as high as 8GHz with minor performance degradation. The IN port is optimized for 30MHz to 6GHz operation while the LO port is always 50Ω matched from 1GHz to 8GHz.

The LTC5576 is optimized for 5V operation, but can be used with a 3.3V supply with slightly reduced performance. The enable function allows the part to be easily shut down for further power savings.

ABSOLUTE MAXIMUM RATINGS

Supply Voltage (V_{CC})	6.0V
Enable Input Voltage (EN)	-0.3V to $V_{CC} + 0.3V$
IADJ Pin Voltage	-0.3V to 2.7V
LO Port Power (1GHz to 8GHz)	+10dBm
IN Port Power (30MHz to 6GHz)	+15dBm
TEMP Input Current	10mA
Operating Temperature Range (T_C)	-40°C to 105°C
Junction Temperature (T_J)	150°C
Storage Temperature Range	-65°C to 150°C

CAUTION: This part is sensitive to electrostatic discharge (ESD). Observe proper ESD precautions when handling the LTC5576.

Design files for this circuit board are available at <http://www.linear.com/demo/DC2322A>

LT, LT, LTC, LTM, Linear Technology and the Linear logo are registered trademarks of Linear Technology Corporation. All other trademarks are the property of their respective owners.

PROPER TEST SETUP

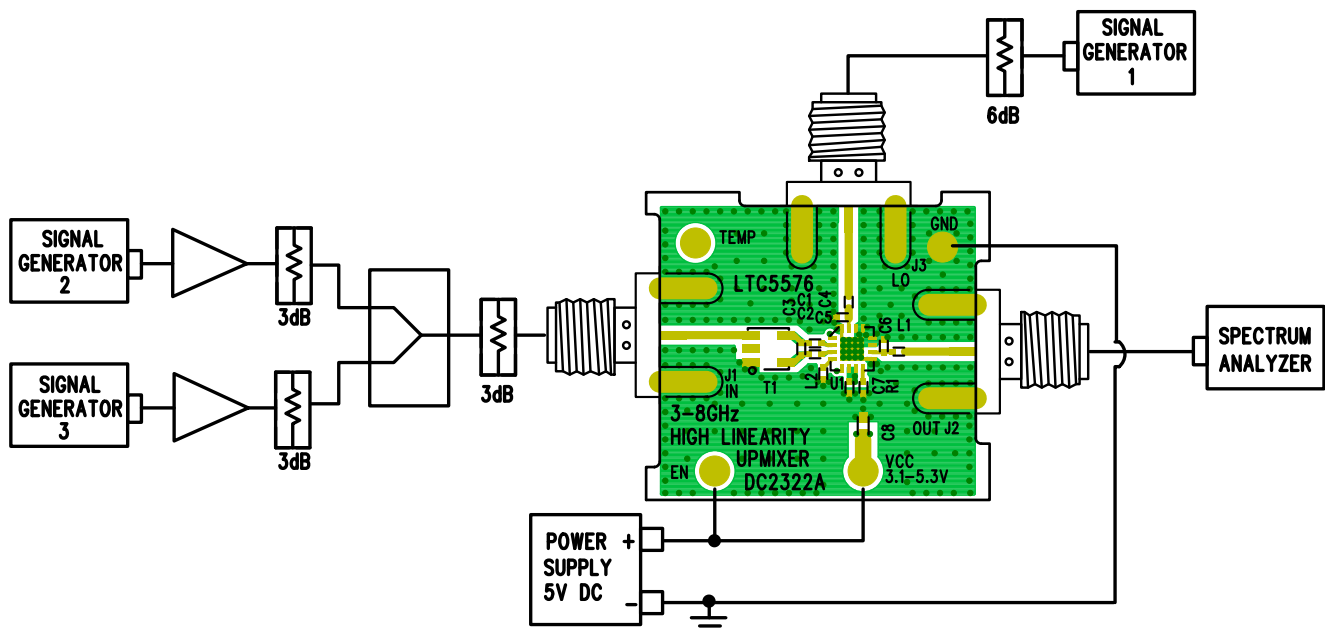

Figure 1. Test Setup for Mixer Two-Tone Measurements

NOTES ON TEST EQUIPMENT AND SETUP

- High performance signal generators with low harmonic outputs should be used for 2-tone measurements. Otherwise, low-pass filters at the signal generator outputs should be used to suppress harmonics.
- High quality combiners should be used to present a broadband 50Ω termination on all ports as well as provide good port-to-port isolation. Adding attenuator pads further improves source isolation and helps prevent the signal generators from producing intermodulation products.
- Spectrum analyzers can produce significant internal distortion products if they are overdriven. Generally, spectrum analyzers are designed to operate at their best with about –30dBm to –40dBm at their input. The spectrum analyzer’s input attenuation setting should be used to avoid saturating the instrument.
- Set the spectrum analyzer’s input attenuation depending on the spectrum analyzer used.
- Before performing measurements on the DUT, the system performance should be evaluated to ensure that a clean input signal is obtained and that the spectrum analyzer’s internal distortion is minimized.

QUICK START PROCEDURE

1. Connect all test equipment as shown in Figure 1.
2. Set the power supply output voltage to 5V, and set the current limit to 150mA.
3. Connect the ground and V_{CC} turrets to the power supply. **BE SURE TO CONNECT THE V_{CC} TURRET BEFORE THE EN TURRET TO ENSURE THAT THE PART DOES NOT GET DAMAGED. ALSO, REMOVE POWER FROM EN TURRET BEFORE REMOVING POWER FROM THE V_{CC} TURRET.**
4. Connect the EN turret to the power supply.
5. Set the LO signal generator to provide a 4900MHz CW signal at about 0dBm to the demo board’s LO port.
6. Set the RF signal generators to provide one 899MHz CW signal and one 901MHz CW signal. The signals should be applied to the 2-way combiner. The output of the combiner should be applied to the demo board’s IN port. The two tones should be set to –10dBm each at the mixer’s IN port.
7. Set the spectrum analyzer’s center frequency to 5.8GHz.
8. Perform various measurements (Conversion Gain, OIP3, LO leakage, etc.)

PARTS LIST

ITEM	QTY	REFERENCE	PART DESCRIPTION	MANUFACTURER/PART NUMBER
1	2	C1, C2	CAP., 1000pF, COG, 50V, 5%, 0402	MURATA, GRM1555C1H102JA01
2	0	C3	DNI, 0402	
3	1	C4	CAP., 100pF, COG, 50V, 5%, 0402	MURATA, GRM1555C1H101JA01
4	1	C5	CAP., 0.3pF, COG, 50V, ±0.05pF, 0402	AVX, 04021J0R3ZBS
5	1	C6	CAP., 0.2pF, COG, 50V, ±0.05pF, 0402	AVX, 04021J0R2ZBS
6	1	C7	CAP., 0.01μF, X7R, 50V, 10%, 0402	MURATA, GRM155R71H103KA88
7	1	C8	CAP., 1μF, X7R, 10V, 10%, 0603	MURATA, GRM188R71A105KA61
8	4	E1-E4	TEST POINT, TURRET, .064 MTG. HOLE	MILL-MAX, 2308-2-00-80-00-00-07-0
9	3	J1-J3	CON., SMA, 50Ω, EDGE-LANCH	E.F. JOHNSON, 142-0701-851
10	2	L1, L2	RES., 0Ω, 0402	VISHAY, CRCW04020000Z0ED
11	1	R1	RES., 2.61k, 1/16W, 1%, 0402	VISHAY, CRCW04022K61FKED
12	1	T1	TRANS., 50Ω, 4.5MHz – 3000MHz, TC1-1-13M+	MINI CIRCUITS, TC1-1-13M+
13	1	U1	IC., HIGH DYNAMIC RANGE ACTIVE MIXER	LINEAR TECH., LTC5576IU

SCHEMATIC DIAGRAM

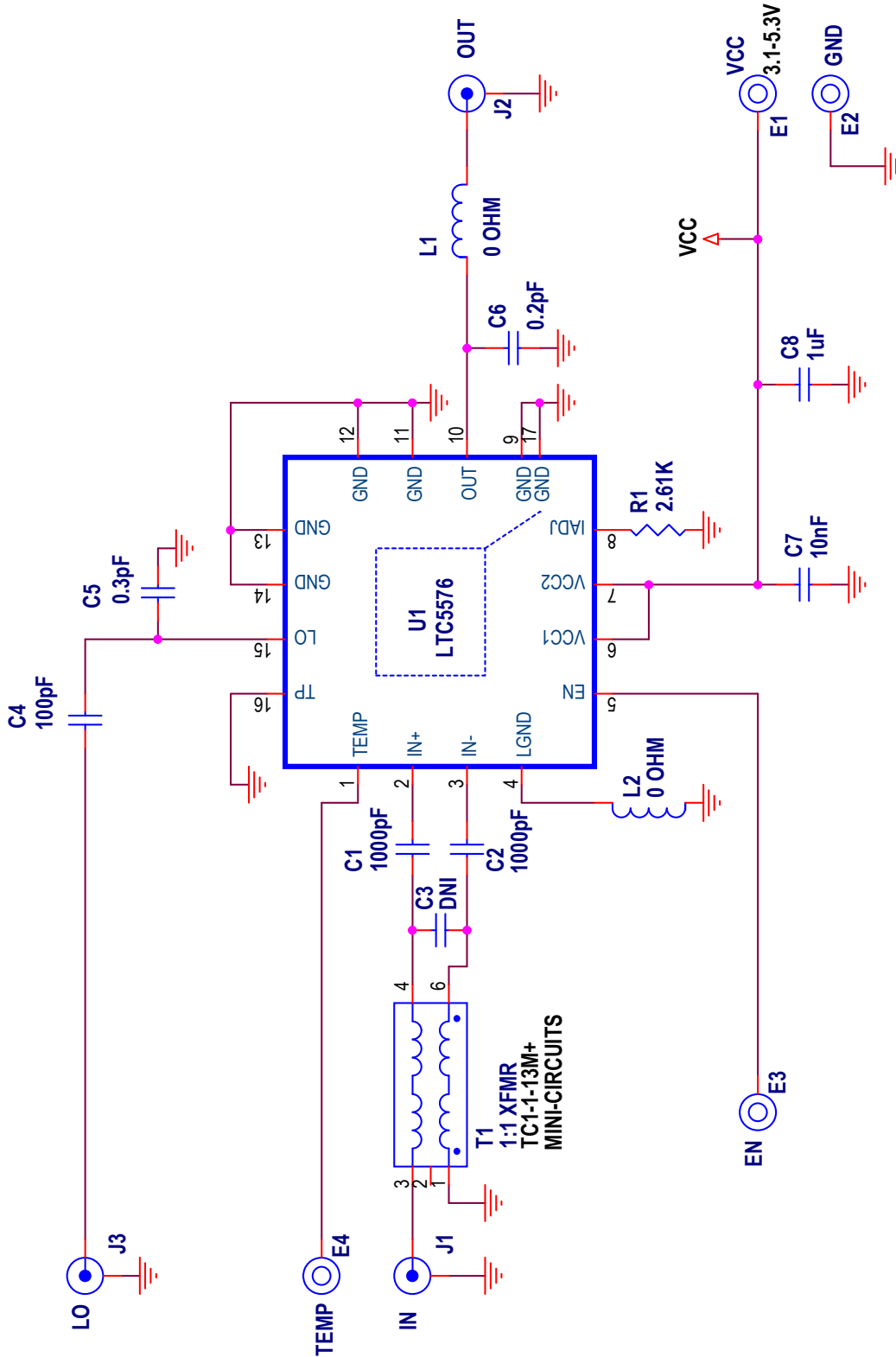

Figure 2: High Linearity Active Upconverting Mixer Schematic

DEMO MANUAL DC2322A

DEMONSTRATION BOARD IMPORTANT NOTICE

Linear Technology Corporation (LTC) provides the enclosed product(s) under the following **AS IS** conditions:

This demonstration board (DEMO BOARD) kit being sold or provided by Linear Technology is intended for use for **ENGINEERING DEVELOPMENT OR EVALUATION PURPOSES ONLY** and is not provided by LTC for commercial use. As such, the DEMO BOARD herein may not be complete in terms of required design-, marketing-, and/or manufacturing-related protective considerations, including but not limited to product safety measures typically found in finished commercial goods. As a prototype, this product does not fall within the scope of the European Union directive on electromagnetic compatibility and therefore may or may not meet the technical requirements of the directive, or other regulations.

If this evaluation kit does not meet the specifications recited in the DEMO BOARD manual the kit may be returned within 30 days from the date of delivery for a full refund. **THE FOREGOING WARRANTY IS THE EXCLUSIVE WARRANTY MADE BY THE SELLER TO BUYER AND IS IN LIEU OF ALL OTHER WARRANTIES, EXPRESSED, IMPLIED, OR STATUTORY, INCLUDING ANY WARRANTY OF MERCHANTABILITY OR FITNESS FOR ANY PARTICULAR PURPOSE. EXCEPT TO THE EXTENT OF THIS INDEMNITY, NEITHER PARTY SHALL BE LIABLE TO THE OTHER FOR ANY INDIRECT, SPECIAL, INCIDENTAL, OR CONSEQUENTIAL DAMAGES.**

The user assumes all responsibility and liability for proper and safe handling of the goods. Further, the user releases LTC from all claims arising from the handling or use of the goods. Due to the open construction of the product, it is the user's responsibility to take any and all appropriate precautions with regard to electrostatic discharge. Also be aware that the products herein may not be regulatory compliant or agency certified (FCC, UL, CE, etc.).

No License is granted under any patent right or other intellectual property whatsoever. **LTC assumes no liability for applications assistance, customer product design, software performance, or infringement of patents or any other intellectual property rights of any kind.**

LTC currently services a variety of customers for products around the world, and therefore this transaction **is not exclusive**.

Please read the DEMO BOARD manual prior to handling the product. Persons handling this product must have electronics training and observe good laboratory practice standards. **Common sense is encouraged.**

This notice contains important safety information about temperatures and voltages. For further safety concerns, please contact a LTC application engineer.

Mailing Address:

Linear Technology
1630 McCarthy Blvd.
Milpitas, CA 95035

Copyright © 2004, Linear Technology Corporation

X-ON Electronics

Largest Supplier of Electrical and Electronic Components

Click to view similar products for [RF Development Tools](#) category:

Click to view products by [Analog Devices](#) manufacturer:

Other Similar products are found below :

[MAAM-011117](#) [MAAP-015036-DIEEV2](#) [EV1HMC1113LP5](#) [EV1HMC6146BLC5A](#) [EV1HMC637ALP5](#) [EVAL-ADG919EBZ](#) [ADL5363-EVALZ](#) [LMV228SDEVAL](#) [SKYA21001-EVB](#) [SMP1331-085-EVB](#) [EV1HMC618ALP3](#) [EVAL01-HMC1041LC4](#) [MAAL-011111-000SMB](#)
[MAAM-009633-001SMB](#) [MASW-000936-001SMB](#) [107712-HMC369LP3](#) [107780-HMC322ALP4](#) [SP000416870](#) [EV1HMC470ALP3](#)
[EV1HMC520ALC4](#) [EV1HMC244AG16](#) [MAX2614EVKIT#](#) [124694-HMC742ALP5](#) [SC20ASATEA-8GB-STD](#) [MAX2837EVKIT+](#)
[MAX2612EVKIT#](#) [MAX2692EVKIT#](#) [EV1HMC629ALP4E](#) [SKY12343-364LF-EVB](#) [108703-HMC452QS16G](#) [EV1HMC863ALC4](#)
[EV1HMC427ALP3E](#) [119197-HMC658LP2](#) [EV1HMC647ALP6](#) [ADL5725-EVALZ](#) [106815-HMC441LM1](#) [EV1HMC1018ALP4](#)
[UXN14M9PE](#) [MAX2016EVKIT](#) [EV1HMC939ALP4](#) [MAX2410EVKIT](#) [MAX2204EVKIT+](#) [EV1HMC8073LP3D](#) [SIMSA868-DKL](#)
[SIMSA868C-DKL](#) [SKY65806-636EK1](#) [SKY68020-11EK1](#) [SKY67159-396EK1](#) [SKY66181-11-EK1](#) [SKY65804-696EK1](#)