

High Current Synchronous Step-Down LED Driver

DESCRIPTION

Demonstration circuit 2339A is a high current synchronous step-down LED driver featuring the LT[®]3744. The unique drive stage used on the LT3744 allows the anodes of three LEDs to be connected together for better heat sinking. This connection will work in both the step-down configuration and the inverting buck-boost configuration. The pros and cons of each configuration can be found in the data sheet. This demonstration circuit 2339A is for customers to test the step-down configuration only. The inverting buck-boost configuration is shown in a separate demonstration circuit.

The input of the demo board is up to 36V. The components are optimized for the efficiency, thermal and PWM dimming for a 12V input. Each of the three outputs is up to 5V, 20A with a 6.05V maximum output voltage limit. The PWM1, PWM2 and PWM3 pins are set to low by default. A DC or PWM signal is required to connect to at least one of the PWM pins to enable the circuit. At any given time, output current only passes through one LED determined by settings of PWM pins.

The CTRL1, CTRL2 and CTRL3 pins can be adjusted to provide accurate analog dimming down to 20:1 ratio.

The minimal input voltage for the LT3744 to operate is 3.3V. However, to maintain the output current regulation in a step down regulator, the minimum input voltage is determined by the LED voltage and the maximum duty cycle. For a 5V output, the demo board minimum input voltage will be around 5.5V at room temperature. The load to be used with this demo board is high current LEDs or laser diodes. Smaller LEDs may not be able to handle the high current, even for a short period of time. It is necessary to mount the LED load on a proper heat sink. A fan may become necessary to avoid exceeding LED's maximum temperature rating.

The typical efficiency of the demo board is 93.5% from a 12V input to 5V, 20A load. The lower the input voltage, the higher the efficiency tends to be for a given load. At output power level of 100W, even one percent of efficiency improvement is a big advantage in minimizing temperature rise. If an efficiency measurement is needed in an application, the output voltage must be measured at the output capacitors instead of the LED load. This prevents cable loss from being counted as a loss of the board.

The demo circuit DC2399A achieves fast current rise time from 0A to 20A in 5 μ s. To see the real rise time, connecting wires between the LED and the board should be as short as possible to minimize the wire inductance and resistance. It is recommended to measure the voltage across R32 with a short 50 Ω coax cable directly into a BNC connector on the oscilloscope. The current can be calculated from the measured voltage. Figure 1 shows the current rise time. A current probe adds more delays to the rise time so using a current probe is not recommended unless rise time is not a concern.

The LT3744 data sheet gives a complete description of the part, operation and application information. The data sheet must be read in conjunction with this quick start guide for demo circuit 2339A.

Design files for this circuit board are available at <http://www.linear.com/demo/DC2339A>

LT, LT, LTC, LTM, Linear Technology and the Linear logo are registered trademarks of Linear Technology Corporation. All other trademarks are the property of their respective owners.

DESCRIPTION

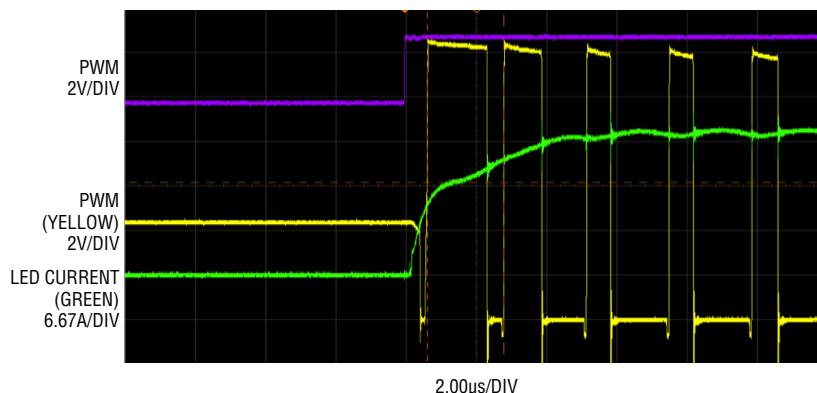

Figure 1. DC2339A Current Rise Time. $V_{IN} = 12V$, LED Voltage = 4.2V when ON. Total LED Current = 20A

PERFORMANCE SUMMARY Specifications are at $T_A = 25^\circ C$

SYMBOL	PARAMETER	CONDITIONS	MIN	TYP	MAX	UNITS
PV_{IN}	Input Supply Voltage	$V_{LED+} = 5V$	5.5		36	V
V_{LED+}	Maximum Output Voltage			6.05		V
I_{OUT}	Output Current	CTRL1, CTRL2, CTRL3 = 1.5V	19	20	21	A
f_{SW}	Switching Frequency		380	425	470	kHz
EFF	Efficiency at DC	$V_{IN} = 12V, I_{OUT} = 20A, V_{OUT} = 5V$		93.5		%

QUICK START PROCEDURE

Demonstration circuit 2339A is easy to set up to evaluate the performance of the LT3744. Refer to Figure 2 for proper measurement equipment setup and follow the procedure below:

1. With power off, connect the input power supply to PV_{IN} and GND. Note: make sure PV_{IN} is below 36V. Connect a DC supply or a PWM signal to PWM1, PWM2 and/or PWM3.
2. With power off, connect the LED load to V_{LED+} and proper $LED1^-$, $LED2^-$, $LED3^-$ according to the setting of the PWM pins.
3. Turn on the power at the input. Turn on PWM1, PWM2 and/or PWM3.
4. Carefully evaluate other design parameters as needed.

QUICK START PROCEDURE

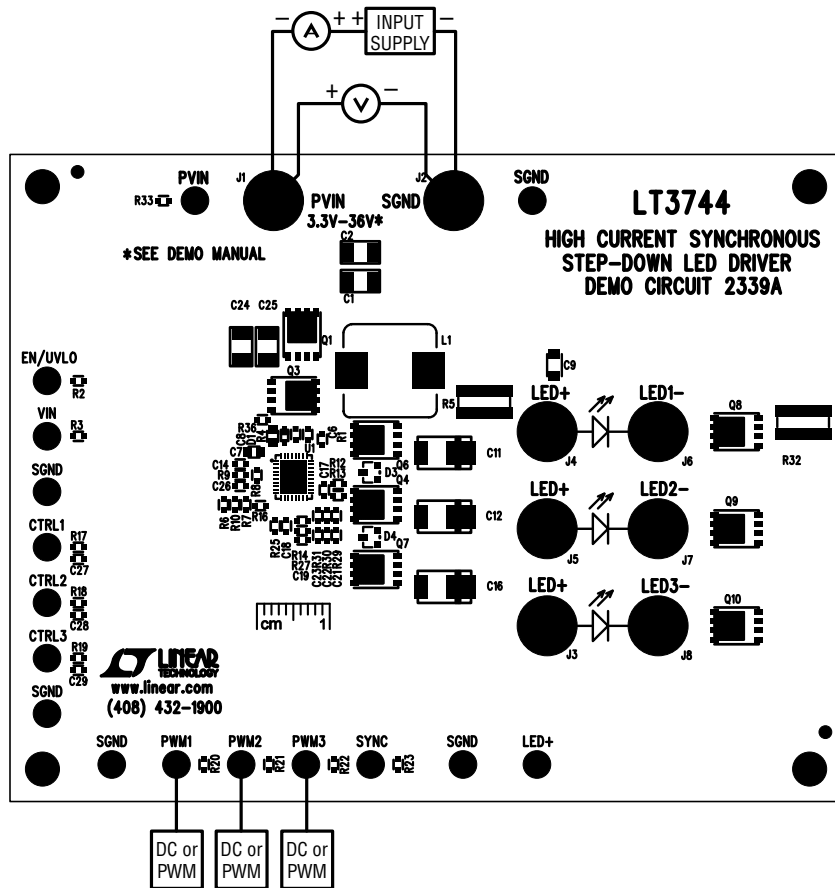

Figure 2. Proper Measurement Equipment Setup

DEMO MANUAL DC2339A

PARTS LIST

ITEM	QTY	REFERENCE	PART DESCRIPTION	MANUFACTURER/PART NUMBER
Required Circuit Components				
1	6	C1, C2, C24, C25, C30, C31	CAP., X7R, 10 μ F, 50V, 10%, 1210	MURATA, GRM32ER71H106KA12L
2	2	C4, C5	CAP., ALUM., ELECT., 56 μ F, 50V	SUN ELECT., 50HVT56M
3	1	C6	CAP., X7R, 0.22 μ F, 25V, 10% 0603	MURATA, GRM188R71E224KA88D
4	1	C7	CAP., X7R, 1 μ F, 50V, 10% 0805	AVX, 08055C105KAT2A
5	1	C8	CAP., X7R, 22 μ F, 6.3V, 10% 0805	AVX, 08056D226KAT2A
6	1	C9	CAP., X5R, 47 μ F, 10V, 10% 1206	MURATA, GRM31CR61A476KE15L
7	3	C11, C12, C16	CAP., POSCAP, 470 μ F, 6.3V, D4D	PANASONIC, 6TPF470MAH
8	1	C14	CAP., X5R, 2.2 μ F, 25V, 10% 0603	MURATA, GRM188R61E225KA12D
9	4	C18, C21, C22, C23	CAP., X7R, 10nF, 25V, 10% 0603	AVX, 06033C103KAT2A
10	5	C26-C29, C19	CAP., X7R, 1nF, 25V, 10% 0603	AVX, 06033C102KAT2A
11	1	D1	SCHOTTKY RECTIFIER, 40V, SOD523	NXP, PMEG4002EB
12	2	D3, D4	DIODE, BAT54A SOT23	DIODES INC., BAT54A-7-F
13	1	L1	INDUCTOR, 0.82 μ H	Würth Elektronik, 744355182
14	2	Q1, Q2	N-CH., 40-V, PG-TDSON-8	INFINEON, BSC035N04LS G
15	2	Q3, Q5	N-CH., 40-V, PG-TDSON-8	INFINEON, BSC026N04LS
16	3	Q4, Q6, Q7	N-CH., 12-V, PowerPAK SO-8	VISHAY, Si7234DP-T1-GE3
17	3	Q8-Q10	N-CH., 40-V, PG-TDSON-8 FL	INFINEON, BSC010N04LS
18	6	R1, R4, R12, R13, R33, R36	RES., CHIP., 0 Ω , 1/10W, 0603	VISHAY, CRC06030000Z0EA
19	10	R3, R6-R8, R10, R20-R23, R25	RES., CHIP., 100K, 1/10W, 1% 0603	VISHAY, CRCW0603100KFKEA
20	2	R5, R32	RES., CHIP., 0.003 Ω , 3W, 1%, KRL6432	SUSUMU, KRL6432E-M-R003-F
21	1	R14	RES., CHIP., 4.02K, 1/10W, 1% 0603	VISHAY, CRCW06034K02FKEA
22	1	R16	RES., CHIP., 82.5K, 1/10W, 1% 0603	VISHAY, CRCW060382K5FKEA
23	3	R17, R18, R19	RES., CHIP., 309K, 1/10W, 1% 0603	VISHAY, CRCW0603309KFKEA
24	1	R27	RES., CHIP., 1k, 1/10W, 1% 0603	VISHAY, CRCW06031K00FKEA
25	3	R29, R30, R31	RES., CHIP., 25.5k, 1/10W, 1% 0603	VISHAY, CRCW060325K5FKEA
26	1	U1	I.C. LT3744EUHE 36PIN, UHE	LINEAR TECH., LT3744EUHE#PBF
Additional Demo Board Circuit Components				
1	0	C10, C13, C15(OPT)	CAP., D4D	
2	0	C17 (OPT)	CAP., 0603	
3	0	D2(OPT)	DIODE, DI123	
4	0	R2, R9(OPT)	RES., CHIP., 0603	
Hardware: For Demo Board Only				
1	16	E1-E16	TESTPOINT, TURRET, 0.094"	MILL-MAX, 2501-2-00-80-00-00-07-0
2	8	J1-J8	JACK BANANA	KEYSTONE, 575-4
3	4	STAND-OFF	STAND-OFF, NYLON, 0.25" (SNAP ON)	KEYSTONE, 8831

SCHEMATIC DIAGRAM

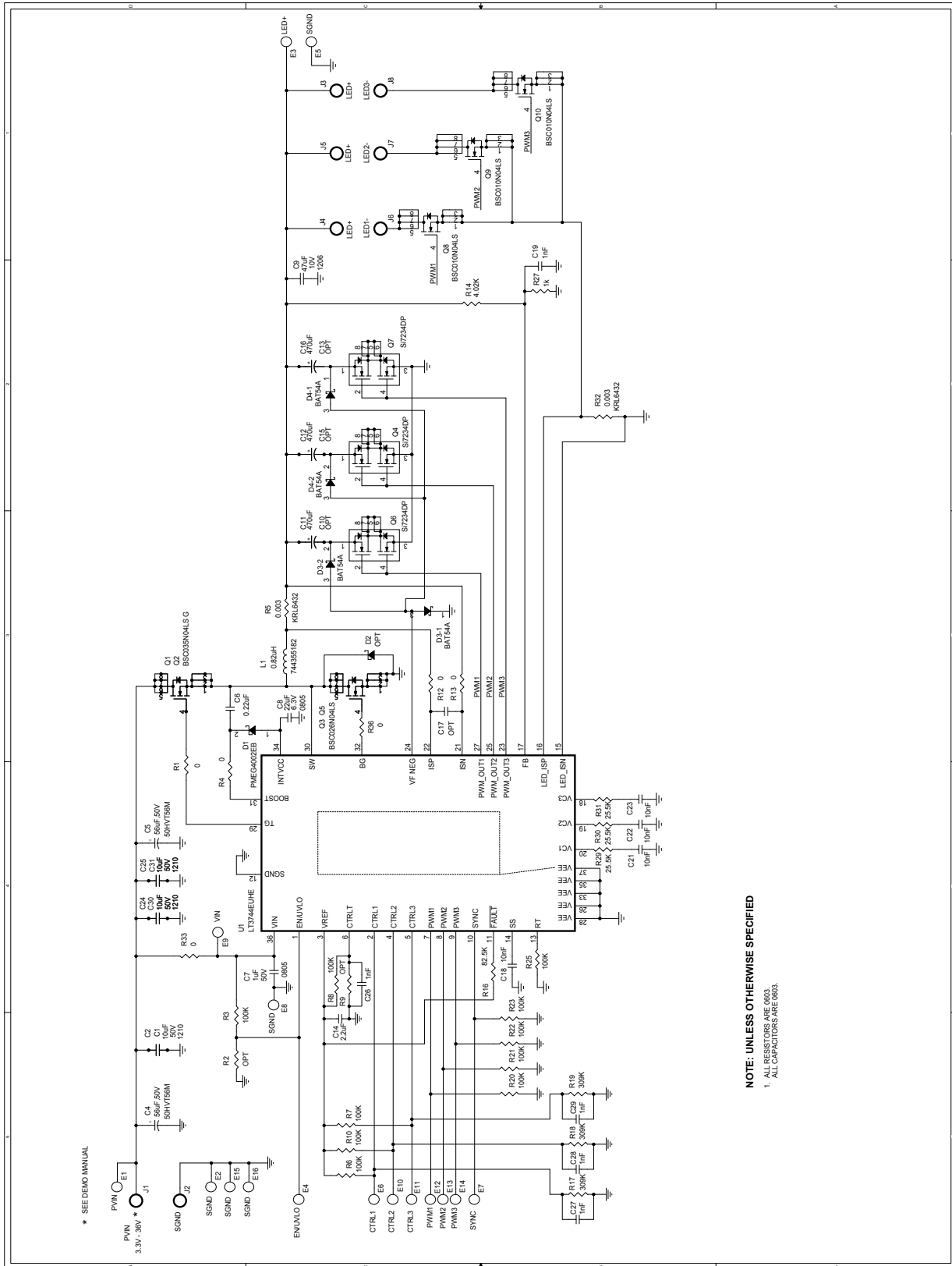

Figure 3. F. DC2339A Demo Circuit Schematic

DEMO MANUAL DC2339A

DEMONSTRATION BOARD IMPORTANT NOTICE

Linear Technology Corporation (LTC) provides the enclosed product(s) under the following **AS IS** conditions:

This demonstration board (DEMO BOARD) kit being sold or provided by Linear Technology is intended for use for **ENGINEERING DEVELOPMENT OR EVALUATION PURPOSES ONLY** and is not provided by LTC for commercial use. As such, the DEMO BOARD herein may not be complete in terms of required design-, marketing-, and/or manufacturing-related protective considerations, including but not limited to product safety measures typically found in finished commercial goods. As a prototype, this product does not fall within the scope of the European Union directive on electromagnetic compatibility and therefore may or may not meet the technical requirements of the directive, or other regulations.

If this evaluation kit does not meet the specifications recited in the DEMO BOARD manual the kit may be returned within 30 days from the date of delivery for a full refund. **THE FOREGOING WARRANTY IS THE EXCLUSIVE WARRANTY MADE BY THE SELLER TO BUYER AND IS IN LIEU OF ALL OTHER WARRANTIES, EXPRESSED, IMPLIED, OR STATUTORY, INCLUDING ANY WARRANTY OF MERCHANTABILITY OR FITNESS FOR ANY PARTICULAR PURPOSE. EXCEPT TO THE EXTENT OF THIS INDEMNITY, NEITHER PARTY SHALL BE LIABLE TO THE OTHER FOR ANY INDIRECT, SPECIAL, INCIDENTAL, OR CONSEQUENTIAL DAMAGES.**

The user assumes all responsibility and liability for proper and safe handling of the goods. Further, the user releases LTC from all claims arising from the handling or use of the goods. Due to the open construction of the product, it is the user's responsibility to take any and all appropriate precautions with regard to electrostatic discharge. Also be aware that the products herein may not be regulatory compliant or agency certified (FCC, UL, CE, etc.).

No License is granted under any patent right or other intellectual property whatsoever. **LTC assumes no liability for applications assistance, customer product design, software performance, or infringement of patents or any other intellectual property rights of any kind.**

LTC currently services a variety of customers for products around the world, and therefore this transaction **is not exclusive**.

Please read the DEMO BOARD manual prior to handling the product. Persons handling this product must have electronics training and observe good laboratory practice standards. **Common sense is encouraged.**

This notice contains important safety information about temperatures and voltages. For further safety concerns, please contact a LTC application engineer.

Mailing Address:

Linear Technology
1630 McCarthy Blvd.
Milpitas, CA 95035

Copyright © 2004, Linear Technology Corporation

X-ON Electronics

Largest Supplier of Electrical and Electronic Components

Click to view similar products for [LED Lighting Development Tools](#) category:

Click to view products by [Analog Devices](#) manufacturer:

Other Similar products are found below :

[MIC2870YFT EV](#) [ADP8860DBCP-EVALZ](#) [LM3404MREVAL](#) [ADM8843EB-EVALZ](#) [TDGL014](#) [ISL97682IRTZEVALZ](#) [LM3508TLEV](#)
[EA6358NH](#) [MAX16826EVKIT](#) [MAX16839EVKIT+](#) [TPS92315EVM-516](#) [MAX1698EVKIT](#) [MAX6956EVKIT+](#) [OM13321,598](#) [DC986A](#)
[DC909A](#) [DC824A](#) [STEVAL-LLL006V1](#) [IS31LT3948-GRLS4-EB](#) [104PW03F](#) [PIM526](#) [PIM527](#) [MAX6946EVKIT+](#) [MAX20070EVKIT#](#)
[MAX21610EVKIT#](#) [MAX20090BEVKIT#](#) [MAX20092EVSYS#](#) [PIM498](#) [AP8800EV1](#) [ZXLD1370/1EV4](#) [MAX6964EVKIT](#)
[MAX25240EVKIT#](#) [MAX25500TEVKITC#](#) [MAX77961BEVKIT06#](#) [1216.1013](#) [TPS61176EVM-566](#) [TPS61197EVM](#) [TPS92001EVM-628](#)
[1270](#) [1271.2004](#) [1272.1030](#) [1273.1010](#) [1278.1010](#) [1279.1002](#) [1279.1001](#) [1282.1000](#) [1293.1900](#) [1293.1800](#) [1293.1700](#) [1293.1500](#)