

Precision, Low Power Differential Amplifier/ADC Driver Family

**FEATURES**

- Available with User Settable Gain or Fixed-Gain of 0.5V/V, 1V/V, or 2V/V
- 2.9nV/ $\sqrt{\text{Hz}}$  Input-Referred Noise
- 2mA Maximum Supply Current
- 45ppm Max Gain Error
- 0.5ppm/ $^{\circ}\text{C}$  Max Gain Error Drift
- 94dB Min CMRR
- 100 $\mu\text{V}$  Max Offset Voltage
- 50nA Max Input Offset Current
- Fast Settling: 720ns to 18-Bit, 8V<sub>P-P</sub> Output
- 2.8V ( $\pm 1.4\text{V}$ ) to 11V ( $\pm 5.5\text{V}$ ) Supply Voltage Range
- Differential Rail-to-Rail Outputs
- Input Common Mode Range Includes Ground
- Low Distortion: 118dB SFDR at 2kHz, 18V<sub>P-P</sub>
- 500MHz Gain-Bandwidth Product
- 35MHz  $-3\text{dB}$  Bandwidth
- Low Power Shutdown: 20 $\mu\text{A}$  ( $V_S = 3\text{V}$ )
- 8-Lead MSOP, 2mm  $\times$  3mm 8-Lead DFN and 3mm  $\times$  3mm 16-lead LFCSP Packages

**APPLICATIONS**

- 20-Bit, 18-Bit and 16-Bit SAR ADC Drivers
- Single-Ended-to-Differential Conversion
- Low Power ADC Drivers
- Level Shifter
- Differential Line Drivers
- Battery-Powered Instrumentation

**DESCRIPTION**

The LTC6363 family consists of four fully differential, low power, low noise amplifiers with rail-to-rail outputs optimized to drive SAR ADCs. The LTC6363 is a standalone differential amplifier, where the gain is typically set using four external resistors. The LTC6363-0.5, LTC6363-1, and LTC6363-2 each have internal matched resistors to create fixed gain blocks with gains of 0.5V/V, 1V/V, and 2V/V respectively. Each of the fixed-gain amplifiers features precision laser trimmed on-chip resistors for accurate, ultrastable gain and excellent CMRR.

**Family Selection Table**

PART NUMBER	GAIN	CONFIGURATION
LTC6363	User Set	
LTC6363-0.5	0.5V/V	
LTC6363-1	1V/V	
LTC6363-2	2V/V	

All registered trademarks and trademarks are the property of their respective owners.

**TYPICAL APPLICATION**

DC-Coupled Interface from a Ground-Referenced Single-Ended Input to an LTC2378-20 SAR ADC

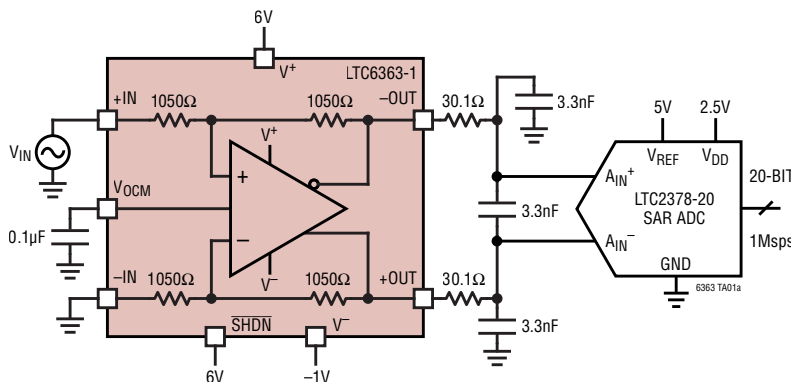

LTC6363-1 Driving LTC2378-20  
 $f_{IN} = 2\text{kHz}$ ,  $-1\text{dBFS}$ , 131k-Point FFT

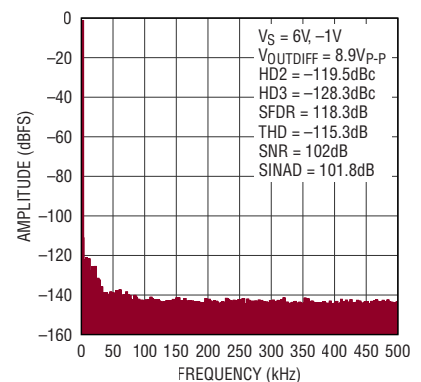

# LTC6363 Family

## ABSOLUTE MAXIMUM RATINGS (Note 1)

Total Supply Voltage ( $V^+ - V^-$ ) .....	12V	Specified Temperature Range (Note 6)	
Input Voltage (+IN, -IN) (Note 2)		LTC6363I/LTC6363I-0.5/LTC6363I-1/ LTC6363I-2 .....	-40°C to 85°C
LTC6363-0.5 .....	( $V^-$ ) - 14.9V to ( $V^+$ ) + 14.9V	LTC6363H/LTC6363H-0.5/LTC6363H-1/ LTC6363H-2 .....	-40°C to 125°C
LTC6363-1 .....	( $V^-$ ) - 11.1V to ( $V^+$ ) + 11.1V	Maximum Junction Temperature .....	150°C
LTC6363-2 .....	( $V^-$ ) - 7.45V to ( $V^+$ ) + 7.45V	Storage Temperature Range .....	-65°C to 150°C
Input Current (+IN, -IN) LTC6363 (Note 3) .....	$\pm 10$ mA	MSOP Lead Temperature (Soldering, 10 sec) .....	300°C
Input Current ( $V_{OCM}$ , SHDN) (Note 3) .....	$\pm 10$ mA		
Output Short-Circuit Duration (Note 4) .....	Thermally Limited		
Operating Temperature Range (Note 5)			
LTC6363I/LTC6363I-0.5/LTC6363I-1/ LTC6363I-2 .....	-40°C to 85°C		
LTC6363H/LTC6363H-0.5/LTC6363H-1/ LTC6363H-2 .....	-40°C to 125°C		

## PIN CONFIGURATION

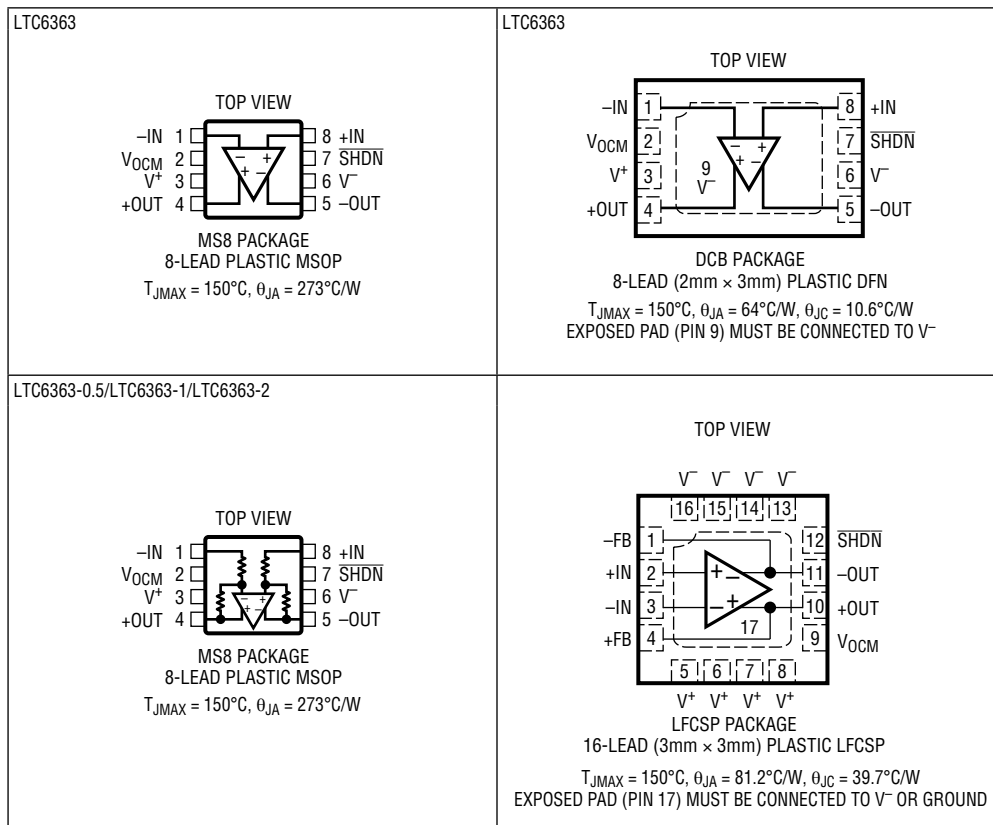

## ORDER INFORMATION

TUBE	TAPE AND REEL	PART MARKING*	PACKAGE DESCRIPTION	TEMPERATURE RANGE
LTC6363IMS8#PBF	LTC6363IMS8#TRPBF	LTGSQ	8-Lead Plastic MSOP	-40°C to 85°C
LTC6363HMS8#PBF	LTC6363HMS8#TRPBF	LTGSQ	8-Lead Plastic MSOP	-40°C to 125°C
LTC6363IMS8-0.5#PBF	LTC6363IMS8-0.5#TRPBF	LTGST	8-Lead Plastic MSOP	-40°C to 85°C
LTC6363HMS8-0.5#PBF	LTC6363HMS8-0.5#TRPBF	LTGST	8-Lead Plastic MSOP	-40°C to 125°C
LTC6363IMS8-1#PBF	LTC6363IMS8-1#TRPBF	LTGSR	8-Lead Plastic MSOP	-40°C to 85°C
LTC6363HMS8-1#PBF	LTC6363HMS8-1#TRPBF	LTGSR	8-Lead Plastic MSOP	-40°C to 125°C
LTC6363IMS8-2#PBF	LTC6363IMS8-2#TRPBF	LTGSS	8-Lead Plastic MSOP	-40°C to 85°C
LTC6363HMS8-2#PBF	LTC6363HMS8-2#TRPBF	LTGSS	8-Lead Plastic MSOP	-40°C to 125°C

## Lead Free Finish

TAPE AND REEL (MINI)	TAPE AND REEL	PART MARKING*	PACKAGE DESCRIPTION	TEMPERATURE RANGE
LTC6363IDCB#TRMPBF	LTC6363IDCB#TRPBF	LGVG	8-Lead (2mm × 3mm) Plastic DFN	-40°C to 85°C
LTC6363HDCB#TRMPBF	LTC6363HDCB#TRPBF	LGVG	8-Lead (2mm × 3mm) Plastic DFN	-40°C to 125°C
LTC6363IRD#PBF	LTC6363IRD#TRPBF	LHJW	16-Lead (3mm × 3mm) Plastic LFCSP	-40°C to 85°C
LTC6363HRD#PBF	LTC6363HRD#TRPBF	LHJW	16-Lead (3mm × 3mm) Plastic LFCSP	-40°C to 125°C

TRM = 500 pieces. \*Temperature grades are identified by a label on the shipping container.

Contact the factory for parts specified with wider operating temperature ranges.

Contact the factory for information on lead based finish parts.

[Tape and reel specifications](#). Some packages are available in 500 unit reels through designated sales channels with #TRMPBF suffix.

**ELECTRICAL CHARACTERISTICS** Complete LTC6363 Family. The ● denotes the specifications which apply over the full operating temperature range, otherwise specifications and typical values are at  $T_A = 25^\circ\text{C}$ .  $V^+ = 10\text{V}$ ,  $V^- = 0\text{V}$ ,  $V_{\text{CM}} = V_{\text{OCM}} = V_{\text{ICM}} = 5\text{V}$ ,  $V_{\text{SHDN}} = \text{open}$ .  $V_S$  is defined as  $(V^+ - V^-)$ .  $V_{\text{OUTCM}}$  is defined as  $(V_{+\text{OUT}} + V_{-\text{OUT}})/2$ .  $V_{\text{ICM}}$  is defined as  $(V_{+\text{IN}} + V_{-\text{IN}})/2$ .  $V_{\text{OUTDIFF}}$  is defined as  $(V_{+\text{OUT}} - V_{-\text{OUT}})$ .

SYMBOL	PARAMETER	CONDITIONS	MIN	TYP	MAX	UNITS
PSRR (Note 7)	Differential Power Supply Rejection ( $\Delta V_S/\Delta V_{\text{OSDIFF}}$ )	$V_S = 2.8\text{V}$ to $11\text{V}$	● 90	125		dB
PSRRCM (Note 7)	Output Common Mode Power Supply Rejection ( $\Delta V_S/\Delta V_{\text{OSCM}}$ )	$V_S = 2.8\text{V}$ to $11\text{V}$	● 70	90		dB
GCM	Common Mode Gain ( $\Delta V_{\text{OUTCM}}/\Delta V_{\text{OCM}}$ )	$V_S = 3\text{V}$ , $V_{\text{OCM}}$ from $0.5\text{V}$ to $2.5\text{V}$ $V_S = 5\text{V}$ , $V_{\text{OCM}}$ from $0.5\text{V}$ to $4.5\text{V}$ $V_S = 10\text{V}$ , $V_{\text{OCM}}$ from $0.5\text{V}$ to $9.5\text{V}$	●	1		V/V
$\Delta\text{GCM}$	Common Mode Gain Error $100 \cdot (\text{GCM} - 1)$	$V_S = 3\text{V}$ , $V_{\text{OCM}}$ from $0.5\text{V}$ to $2.5\text{V}$ $V_S = 5\text{V}$ , $V_{\text{OCM}}$ from $0.5\text{V}$ to $4.5\text{V}$ $V_S = 10\text{V}$ , $V_{\text{OCM}}$ from $0.5\text{V}$ to $9.5\text{V}$	●	0.2	1	%
BAL	Output Balance ( $\Delta V_{\text{OUTCM}}/\Delta V_{\text{OUTDIFF}}$ )	$\Delta V_{\text{OUTDIFF}} = 2\text{V}$ Single-Ended Input Differential Input	●	-58	-35	dB
$V_{\text{OSCM}}$	Common Mode Offset Voltage ( $V_{\text{OUTCM}} - V_{\text{OCM}}$ )	$V_S = 3\text{V}$ $V_S = 5\text{V}$ $V_S = 10\text{V}$	●	±1	±6	mV
$\Delta V_{\text{OSCM}}/\Delta T$	Common Mode Offset Voltage Drift		●	10		$\mu\text{V}/^\circ\text{C}$
$V_{\text{OUTCMR}}$ (Note 9)	Output Signal Common Mode Range (Voltage Range for the $V_{\text{OCM}}$ Pin)	$V_{\text{OCM}}$ Driven Externally, $V_S = 3\text{V}$ $V_{\text{OCM}}$ Driven Externally, $V_S = 5\text{V}$ $V_{\text{OCM}}$ Driven Externally, $V_S = 10\text{V}$	●	0.5	2.5	V
			●	0.5	4.5	V
			●	0.5	9.5	V

# LTC6363 Family

**ELECTRICAL CHARACTERISTICS** Complete LTC6363 Family. The ● denotes the specifications which apply over the full operating temperature range, otherwise specifications and typical values are at  $T_A = 25^\circ\text{C}$ .  $V^+ = 10\text{V}$ ,  $V^- = 0\text{V}$ ,  $V_{\text{CM}} = V_{\text{OCM}} = V_{\text{ICM}} = 5\text{V}$ ,  $V_{\text{SHDN}} = \text{open}$ .  $V_S$  is defined as  $(V^+ - V^-)$ .  $V_{\text{OUTCM}}$  is defined as  $(V_{+\text{OUT}} + V_{-\text{OUT}})/2$ .  $V_{\text{ICM}}$  is defined as  $(V_{+\text{IN}} + V_{-\text{IN}})/2$ .  $V_{\text{OUTDIFF}}$  is defined as  $(V_{+\text{OUT}} - V_{-\text{OUT}})$ .

SYMBOL	PARAMETER	CONDITIONS	MIN	TYP	MAX	UNITS	
$V_{\text{OCM}}$	Self-Biased Voltage at the $V_{\text{OCM}}$ Pin	$V_{\text{OCM}}$ Not Connected, $V_S = 3\text{V}$	●	1.38	1.5	1.82	V
		$V_{\text{OCM}}$ Not Connected, $V_S = 5\text{V}$	●	2.33	2.5	2.82	V
		$V_{\text{OCM}}$ Not Connected, $V_S = 10\text{V}$	●	4.79	5	5.21	V
$R_{\text{INVOCM}}$	Input Resistance, $V_{\text{OCM}}$ Pin		●	1.3	1.8	2.3	$\text{M}\Omega$
	$V_{\text{OCM}}$ Bandwidth			15		$\text{MHz}$	
$V_S$	Supply Voltage Range	Guaranteed by PSRR	●	2.8	11	V	
$I_S$	Supply Current	$V_S = 3\text{V}$ , Active	●		1.7	1.8	$\text{mA}$
		$V_S = 3\text{V}$ , Shutdown	●		20	40	$\mu\text{A}$
		$V_S = 5\text{V}$ , Active	●		1.75	1.85	$\text{mA}$
		$V_S = 5\text{V}$ , Shutdown	●			2	$\text{mA}$
		$V_S = 10\text{V}$ , Active	●		1.9	2	$\text{mA}$
		$V_S = 10\text{V}$ , Shutdown	●			2.2	$\text{mA}$
$I_S$		$V_S = 10\text{V}$ , Shutdown	●	70	130	$\mu\text{A}$	
$V_{\text{IL}}$	$\overline{\text{SHDN}}$ Input Logic Low		●	$(V^+ + V^-)/2 + 0.4$		V	
$V_{\text{IH}}$	$\overline{\text{SHDN}}$ Input Logic High		●	$(V^+ + V^-)/2 + 1.2$		V	
$t_{\text{ON}}$	Turn-On Time			4		$\mu\text{s}$	
$t_{\text{OFF}}$	Turn-Off Time			2		$\mu\text{s}$	
$R_{\text{SHDN}}$	Input Resistance, $\overline{\text{SHDN}}$ Pin		●	300	500	700	$\text{k}\Omega$

**LTC6363 Only.** The ● denotes the specifications which apply over the full operating temperature range, otherwise specifications and typical values are at  $T_A = 25^\circ\text{C}$ .  $V^+ = 10\text{V}$ ,  $V^- = 0\text{V}$ ,  $V_{\text{CM}} = V_{\text{OCM}} = V_{\text{ICM}} = 5\text{V}$ ,  $V_{\text{SHDN}} = \text{open}$ .  $V_S$  is defined as  $(V^+ - V^-)$ .  $V_{\text{OUTCM}}$  is defined as  $(V_{+\text{OUT}} + V_{-\text{OUT}})/2$ .  $V_{\text{ICM}}$  is defined as  $(V_{+\text{IN}} + V_{-\text{IN}})/2$ .  $V_{\text{OUTDIFF}}$  is defined as  $(V_{+\text{OUT}} - V_{-\text{OUT}})$ . Typical specifications apply to the internal amplifier inside all versions.

SYMBOL	PARAMETER	CONDITIONS	MIN	TYP	MAX	UNITS	
$V_{\text{OSDIFF}}$ (Note 7)	Differential Offset Voltage	$V_S = 3\text{V}$ $V_{\text{ICM}} = 1.5\text{V}$	●	25	100	$\mu\text{V}$	
		$V_S = 5\text{V}$ $V_{\text{ICM}} = 2.5\text{V}$	●	25	100	$\mu\text{V}$	
		$V_S = 10\text{V}$ $V_{\text{ICM}} = 5\text{V}$	●	25	100	$\mu\text{V}$	
$\Delta V_{\text{OSDIFF}}/\Delta T$ (Notes 7, 8)	Differential Offset Voltage Drift	$V_S = 3\text{V}$	●	0.45	1.25	$\mu\text{V}/^\circ\text{C}$	
		$V_S = 5\text{V}$	●	0.45	1.25	$\mu\text{V}/^\circ\text{C}$	
		$V_S = 10\text{V}$	●	0.45	1.25	$\mu\text{V}/^\circ\text{C}$	
$A_{\text{VOL}}$	Open-Loop Voltage Gain			125		$\text{dB}$	
$I_B$ (Note 10)	Input Bias Current	$V_S = 3\text{V}$	●	-1	-0.5	-0.1	$\mu\text{A}$
		$V_S = 5\text{V}$	●	-1	-0.5	-0.1	$\mu\text{A}$
		$V_S = 10\text{V}$	●	-1	-0.5	-0.1	$\mu\text{A}$
$I_{\text{OS}}$ (Note 10)	Input Offset Current	$V_S = 3\text{V}$	●		$\pm 5$	$\pm 50$	$\text{nA}$
		$V_S = 5\text{V}$	●		$\pm 5$	$\pm 50$	$\text{nA}$
		$V_S = 10\text{V}$	●		$\pm 5$	$\pm 50$	$\text{nA}$

**ELECTRICAL CHARACTERISTICS** LTC6363 Only. The ● denotes the specifications which apply over the full operating temperature range, otherwise specifications and typical values are at  $T_A = 25^\circ\text{C}$ .  $V^+ = 10\text{V}$ ,  $V^- = 0\text{V}$ ,  $V_{\text{CM}} = V_{\text{OCM}} = V_{\text{ICM}} = 5\text{V}$ ,  $V_{\text{SHDN}} = \text{open}$ .  $V_S$  is defined as  $(V^+ - V^-)$ .  $V_{\text{OUTCM}}$  is defined as  $(V_{\text{+OUT}} + V_{\text{-OUT}})/2$ .  $V_{\text{ICM}}$  is defined as  $(V_{\text{+IN}} + V_{\text{-IN}})/2$ .  $V_{\text{OUTDIFF}}$  is defined as  $(V_{\text{+OUT}} - V_{\text{-OUT}})$ . Typical specifications apply to the internal amplifier inside all versions.

SYMBOL	PARAMETER	CONDITIONS	MIN	TYP	MAX	UNITS	
$\Delta I_{\text{OS}}/\Delta T$ (Note 8)	Input Offset Current Drift	$V_S = 3\text{V}$	●	$\pm 30$	$\pm 150$	$\mu\text{A}/^\circ\text{C}$	
		$V_S = 5\text{V}$	●	$\pm 30$	$\pm 150$	$\mu\text{A}/^\circ\text{C}$	
		$V_S = 10\text{V}$	●	$\pm 30$	$\pm 150$	$\mu\text{A}/^\circ\text{C}$	
$R_{\text{IN}}$	Input Resistance	Common Mode		50		$\text{M}\Omega$	
		Differential Mode		40		$\text{k}\Omega$	
$C_{\text{IN}}$	Input Capacitance	Differential Mode		2		$\text{pF}$	
$e_n$ (Note 7)	Differential Input Noise Voltage Differential Input Noise Voltage Density	0.1Hz to 10Hz		2.5		$\mu\text{V}_{\text{P-P}}$	
		$f = 100\text{kHz}$ (Not Including $R_{\text{I}}/R_{\text{F}}$ )		2.9		$\text{nV}/\sqrt{\text{Hz}}$	
$e_{\text{nvocm}}$	Common Mode Noise Voltage Density	$f = 100\text{kHz}$		20		$\text{nV}/\sqrt{\text{Hz}}$	
$i_n$	Input Noise Current Density	$f = 100\text{kHz}$ (Not Including $R_{\text{I}}/R_{\text{F}}$ )		0.55		$\text{pA}/\sqrt{\text{Hz}}$	
$V_{\text{ICMR}}$ (Note 9)	Input Common Mode Range	$V_S = 3\text{V}$	●	0	1.8	V	
		$V_S = 5\text{V}$	●	0	3.8	V	
		$V_S = 10\text{V}$	●	0	8.8	V	
$\text{CMRRI}$ (Note 7)	Input Common Mode Rejection Ratio (Input Referred) $\Delta V_{\text{ICM}}/\Delta V_{\text{OSDIFF}}$	$V_S = 3\text{V}$ , $V_{\text{ICM}}$ from 0V to 1.8V	●	78	110	dB	
		$V_S = 5\text{V}$ , $V_{\text{ICM}}$ from 0V to 3.8V	●	85	115	dB	
		$V_S = 10\text{V}$ , $V_{\text{ICM}}$ from 0V to 8.8V	●	90	120	dB	
$\text{CMRRI0}$ (Note 7)	Output Common Mode Rejection Ratio (Input Referred) $\Delta V_{\text{OCM}}/\Delta V_{\text{OSDIFF}}$	$V_S = 3\text{V}$ , $V_{\text{OCM}}$ from 0.5V to 2.5V	●	70	120	dB	
		$V_S = 5\text{V}$ , $V_{\text{OCM}}$ from 0.5V to 4.5V	●	80	120	dB	
		$V_S = 10\text{V}$ , $V_{\text{OCM}}$ from 0.5V to 9.5V	●	90	120	dB	
$V_{\text{OUT}}$	Output Voltage, High, Either Output Pin	$I_{\text{L}} = 0\text{mA}$ , $V_S = 3\text{V}$	●	2.8	2.88	V	
		$I_{\text{L}} = -5\text{mA}$ , $V_S = 3\text{V}$	●	2.75	2.83	V	
		$I_{\text{L}} = 0\text{mA}$ , $V_S = 5\text{V}$	●	4.8	4.88	V	
		$I_{\text{L}} = -5\text{mA}$ , $V_S = 5\text{V}$	●	4.75	4.83	V	
	Output Voltage, Low, Either Output Pin	$I_{\text{L}} = 0\text{mA}$ , $V_S = 3\text{V}$	●		0.1	0.15	V
		$I_{\text{L}} = 5\text{mA}$ , $V_S = 3\text{V}$	●		0.15	0.25	V
		$I_{\text{L}} = 0\text{mA}$ , $V_S = 5\text{V}$	●		0.1	0.15	V
		$I_{\text{L}} = 5\text{mA}$ , $V_S = 5\text{V}$	●		0.15	0.25	V
$I_{\text{SC}}$	Output Short-Circuit Current, Either Output Pin, Sinking	$V_S = 3\text{V}$ , Output Shorted to 1.5V	●	12	25	mA	
		$V_S = 5\text{V}$ , Output Shorted to 2.5V	●	13	35	mA	
	Output Short-Circuit Current, Either Output Pin, Sourcing	$V_S = 3\text{V}$ , Output Shorted to 1.5V	●	25	55	mA	
		$V_S = 5\text{V}$ , Output Shorted to 2.5V	●	27	75	mA	
$\text{GBW}$	Gain-Bandwidth Product	$f_{\text{TEST}} = 200\text{kHz}$	●	390	500	MHz	
				230		MHz	
$f_{-3\text{dB}}$	-3dB Bandwidth	$R_{\text{I}} = R_{\text{F}} = 1\text{k}$		35		MHz	
SR	Slew Rate	Differential $18\text{V}_{\text{P-P}}$ Output		75		$\text{V}/\mu\text{s}$	
FPBW (Note 11)	Full Power Bandwidth	$10\text{V}_{\text{P-P}}$ Output		2.4		MHz	
		$18\text{V}_{\text{P-P}}$ Output		1.3		MHz	
HD2/HD3	2nd/3rd Order Harmonic Distortion Single-Ended Input	$f = 1\text{kHz}$ , $V_{\text{OUT}} = 18\text{V}_{\text{P-P}}$		-123/-128		dBc	
		$f = 10\text{kHz}$ , $V_{\text{OUT}} = 18\text{V}_{\text{P-P}}$		-120/-108		dBc	
		$f = 100\text{kHz}$ , $V_{\text{OUT}} = 18\text{V}_{\text{P-P}}$		-92/-85		dBc	

# LTC6363 Family

**ELECTRICAL CHARACTERISTICS** LTC6363-0.5 Only. The ● denotes the specifications which apply over the full operating temperature range, otherwise specifications and typical values are at  $T_A = 25^\circ\text{C}$ .  $V^+ = 10\text{V}$ ,  $V^- = 0\text{V}$ ,  $V_{\text{CM}} = V_{\text{OCM}} = V_{\text{ICM}} = 5\text{V}$ ,  $V_{\text{SHDN}} = \text{open}$ .  $V_S$  is defined as  $(V^+ - V^-)$ .  $V_{\text{OUTCM}}$  is defined as  $(V_{+\text{OUT}} + V_{-\text{OUT}})/2$ .  $V_{\text{ICM}}$  is defined as  $(V_{+\text{IN}} + V_{-\text{IN}})/2$ .  $V_{\text{OUTDIFF}}$  is defined as  $(V_{+\text{OUT}} - V_{-\text{OUT}})$ .

SYMBOL	PARAMETER	CONDITIONS	MIN	TYP	MAX	UNITS
$t_S$	Settling Time to a $8V_{\text{P-P}}$ Output Step	0.1%		290		ns
		0.01%		330		ns
		0.0015% (16-Bit)		370		ns
		4ppm (18-Bit)		720		ns
$V_{\text{OSDIFF}}$ (Note 7)	Differential Offset Voltage	$V_S = 3\text{V}$ $V_{\text{ICM}} = 1.5\text{V}$	●	25	125	$\mu\text{V}$ $\mu\text{V}$
		$V_S = 5\text{V}$ $V_{\text{ICM}} = 2.5\text{V}$	●	25	125	$\mu\text{V}$ $\mu\text{V}$
		$V_S = 10\text{V}$ $V_{\text{ICM}} = 5\text{V}$	●	25	125	$\mu\text{V}$ $\mu\text{V}$
$\Delta V_{\text{OSDIFF}}/\Delta T$ (Notes 7, 8)	Differential Offset Voltage Drift	$V_S = 3\text{V}$	●	0.45	1.25	$\mu\text{V}/^\circ\text{C}$
		$V_S = 5\text{V}$	●	0.45	1.25	$\mu\text{V}/^\circ\text{C}$
		$V_S = 10\text{V}$	●	0.45	1.25	$\mu\text{V}/^\circ\text{C}$
$G_{\text{DIFF}}$	Differential Gain	$V_{\text{OUT}} = 16V_{\text{P-P}}$		0.5		V/V
		Differential Gain Error	●	$\pm 0.002$	$\pm 0.0045$ $\pm 0.0075$	% %
		Differential Gain Nonlinearity		0.5		ppm
		Differential Gain Drift vs Temperature (Note 8)	●	$\pm 0.2$	$\pm 0.5$	ppm/ $^\circ\text{C}$
$e_n$ (Note 7)	Differential Input Referred Noise Voltage Density	$f = 100\text{kHz}$ , (Includes Internal Resistor Noise)		15.1		$\text{nV}/\sqrt{\text{Hz}}$
$e_{\text{nvocm}}$	Common Mode Noise Voltage Density	$f = 100\text{kHz}$		20		$\text{nV}/\sqrt{\text{Hz}}$
$R_{\text{IN}}$	Input Resistance	Common Mode		1050		$\Omega$
		Differential Mode		2800		$\Omega$
$C_{\text{IN}}$	Input Capacitance	Differential Mode		2.5		pF
		Common Mode		13.5		pF
$V_{\text{ICMR}}$ (Note 9)	Input Common Mode Range	$V_S = 3\text{V}$ , $V_{\text{OCM}} = 1.5\text{V}$	●	-3	2.4	V
		$V_S = 5\text{V}$ , $V_{\text{OCM}} = 2.5\text{V}$	●	-5	6.4	V
		$V_S = 10\text{V}$ , $V_{\text{OCM}} = 5\text{V}$	●	-10	16.4	V
$\text{CMRRI}$ (Note 7)	Input Common Mode Rejection Ratio (Input Referred) $\Delta V_{\text{ICM}}/\Delta V_{\text{OSDIFF}}$	$V_S = 3\text{V}$ , $V_{\text{ICM}}$ from -3V to 2.4V	●	90 80	106	dB dB
		$V_S = 5\text{V}$ , $V_{\text{ICM}}$ from -5V to 6.4V	●	94 85	106	dB dB
		$V_S = 10\text{V}$ , $V_{\text{ICM}}$ from -10V to 16.4V	●	94 85	106	dB dB
			●	85		dB
$\text{CMRRI}$ (Note 7)	Output Common Mode Rejection Ratio (Input Referred) $\Delta V_{\text{OCM}}/\Delta V_{\text{OSDIFF}}$	$V_S = 3\text{V}$ , $V_{\text{OCM}}$ from 0.5V to 2.5V	●	85 80	100	dB dB
		$V_S = 5\text{V}$ , $V_{\text{OCM}}$ from 0.5V to 4.5V	●	90 85	106	dB dB
		$V_S = 10\text{V}$ , $V_{\text{OCM}}$ from 0.5V to 9.5V	●	90 85	106	dB dB
			●	85		dB

**ELECTRICAL CHARACTERISTICS** LTC6363-0.5 Only. The ● denotes the specifications which apply over the full operating temperature range, otherwise specifications and typical values are at  $T_A = 25^\circ\text{C}$ .  $V^+ = 10\text{V}$ ,  $V^- = 0\text{V}$ ,  $V_{\text{CM}} = V_{\text{OCM}} = V_{\text{ICM}} = 5\text{V}$ ,  $V_{\text{SHDN}} = \text{open}$ .  $V_S$  is defined as  $(V^+ - V^-)$ .  $V_{\text{OUTCM}}$  is defined as  $(V_{+\text{OUT}} + V_{-\text{OUT}})/2$ .  $V_{\text{ICM}}$  is defined as  $(V_{+\text{IN}} + V_{-\text{IN}})/2$ .  $V_{\text{OUTDIFF}}$  is defined as  $(V_{+\text{OUT}} - V_{-\text{OUT}})$ .

SYMBOL	PARAMETER	CONDITIONS	MIN	TYP	MAX	UNITS	
$V_{\text{OUT}}$	Output Voltage, High, Either Output Pin	$I_L = 0\text{mA}$ , $V_S = 3\text{V}$	●	2.77	2.88	V	
		$I_L = -5\text{mA}$ , $V_S = 3\text{V}$	●	2.74	2.83	V	
		$I_L = 0\text{mA}$ , $V_S = 5\text{V}$	●	4.75	4.86	V	
		$I_L = -5\text{mA}$ , $V_S = 5\text{V}$	●	4.72	4.81	V	
	Output Voltage, Low, Either Output Pin	$I_L = 0\text{mA}$ , $V_S = 10\text{V}$	●	9.72	9.83	V	
		$I_L = -5\text{mA}$ , $V_S = 10\text{V}$	●	9.64	9.78	V	
		$I_L = 0\text{mA}$ , $V_S = 3\text{V}$	●		0.11	0.19	V
		$I_L = 5\text{mA}$ , $V_S = 3\text{V}$	●		0.19	0.27	V
	$I_L = 0\text{mA}$ , $V_S = 5\text{V}$	●		0.13	0.2	V	
	$I_L = 5\text{mA}$ , $V_S = 5\text{V}$	●		0.19	0.28	V	
	$I_L = 0\text{mA}$ , $V_S = 10\text{V}$	●		0.17	0.28	V	
	$I_L = 5\text{mA}$ , $V_S = 10\text{V}$	●		0.23	0.38	V	
$I_{\text{SC}}$	Output Short-Circuit Current, Either Output Pin, Sinking	$V_S = 3\text{V}$ , Output Shorted to 1.5V	●	12	25	mA	
		$V_S = 5\text{V}$ , Output Shorted to 2.5V	●	13	35	mA	
		$V_S = 10\text{V}$ , Output Shorted to 5V	●	14	40	mA	
	Output Short-Circuit Current, Either Output Pin, Sourcing	$V_S = 3\text{V}$ , Output Shorted to 1.5V	●	25	55	mA	
	$V_S = 5\text{V}$ , Output Shorted to 2.5V	●	27	75	mA		
	$V_S = 10\text{V}$ , Output Shorted to 5V	●	30	90	mA		
$f_{-3\text{dB}}$	-3dB Bandwidth			35		MHz	
SR	Slew Rate	Differential 18V <sub>P-P</sub> Output		44		V/ $\mu\text{s}$	
FPBW (Note 11)	Full Power Bandwidth	10V <sub>P-P</sub> Output		1.4		MHz	
		18V <sub>P-P</sub> Output		0.8		MHz	
HD2/HD3	2nd/3rd order Harmonic Distortion Single-Ended Input	$f = 1\text{kHz}$ , $V_{\text{OUT}} = 10\text{V}_{\text{P-P}}$		-125/-122		dBc	
		$f = 10\text{kHz}$ , $V_{\text{OUT}} = 10\text{V}_{\text{P-P}}$		-108/-111		dBc	
		$f = 100\text{kHz}$ , $V_{\text{OUT}} = 10\text{V}_{\text{P-P}}$		-87/-78		dBc	
$t_s$	Settling Time to a 8V <sub>P-P</sub> Output Step	0.1%		420		ns	
		0.01%		440		ns	
		0.0015% (16-Bit)		550		ns	
		4ppm (18-Bit)		740		ns	

**LTC6363-1 Only.** The ● denotes the specifications which apply over the full operating temperature range, otherwise specifications and typical values are at  $T_A = 25^\circ\text{C}$ .  $V^+ = 10\text{V}$ ,  $V^- = 0\text{V}$ ,  $V_{\text{CM}} = V_{\text{OCM}} = V_{\text{ICM}} = 5\text{V}$ ,  $V_{\text{SHDN}} = \text{open}$ .  $V_S$  is defined as  $(V^+ - V^-)$ .  $V_{\text{OUTCM}}$  is defined as  $(V_{+\text{OUT}} + V_{-\text{OUT}})/2$ .  $V_{\text{ICM}}$  is defined as  $(V_{+\text{IN}} + V_{-\text{IN}})/2$ .  $V_{\text{OUTDIFF}}$  is defined as  $(V_{+\text{OUT}} - V_{-\text{OUT}})$ .

SYMBOL	PARAMETER	CONDITIONS	MIN	TYP	MAX	UNITS
$V_{\text{OSDIFF}}$ (Note 7)	Differential Offset Voltage	$V_S = 3\text{V}$ $V_{\text{ICM}} = 1.5\text{V}$	●	25	125	$\mu\text{V}$
		$V_S = 5\text{V}$ $V_{\text{ICM}} = 2.5\text{V}$	●	25	125	$\mu\text{V}$
		$V_S = 10\text{V}$ $V_{\text{ICM}} = 5\text{V}$	●	25	125	$\mu\text{V}$
$\Delta V_{\text{OSDIFF}}/\Delta T$ (Notes 7, 8)	Differential Offset Voltage Drift	$V_S = 3\text{V}$	●	0.45	1.25	$\mu\text{V}/^\circ\text{C}$
		$V_S = 5\text{V}$	●	0.45	1.25	$\mu\text{V}/^\circ\text{C}$
		$V_S = 10\text{V}$	●	0.45	1.25	$\mu\text{V}/^\circ\text{C}$
$G_{\text{DIFF}}$	Differential Gain	$V_{\text{OUT}} = 16\text{V}_{\text{P-P}}$		1		V/V
		Differential Gain Error	●	$\pm 0.002$	$\pm 0.0045$ $\pm 0.0075$	% %
	Differential Gain Nonlinearity			0.5		ppm
	Differential Gain Drift vs Temperature (Note 8)	●	$\pm 0.2$	$\pm 0.5$		ppm/ $^\circ\text{C}$

# LTC6363 Family

**ELECTRICAL CHARACTERISTICS** LTC6363-1 Only. The ● denotes the specifications which apply over the full operating temperature range, otherwise specifications and typical values are at  $T_A = 25^\circ\text{C}$ .  $V^+ = 10\text{V}$ ,  $V^- = 0\text{V}$ ,  $V_{\text{CM}} = V_{\text{OCM}} = V_{\text{ICM}} = 5\text{V}$ ,  $V_{\text{SHDN}} = \text{open}$ .  $V_S$  is defined as  $(V^+ - V^-)$ .  $V_{\text{OUTCM}}$  is defined as  $(V_{+OUT} + V_{-OUT})/2$ .  $V_{\text{ICM}}$  is defined as  $(V_{+IN} + V_{-IN})/2$ .  $V_{\text{OUTDIFF}}$  is defined as  $(V_{+OUT} - V_{-OUT})$ .

SYMBOL	PARAMETER	CONDITIONS	MIN	TYP	MAX	UNITS	
$e_n$ (Note 7)	Differential Input Referred Noise Voltage Density	$f = 100\text{kHz}$ , (Includes Internal Resistor Noise)		10.5		$\text{nV}/\sqrt{\text{Hz}}$	
$e_{\text{nvocm}}$	Common Mode Noise Voltage Density	$f = 100\text{kHz}$		20		$\text{nV}/\sqrt{\text{Hz}}$	
$R_{\text{IN}}$	Input Resistance	Common Mode Differential Mode		1050 2100		$\Omega$ $\Omega$	
$C_{\text{IN}}$	Input Capacitance	Differential Mode Common Mode		1.5 13.5		$\text{pF}$ $\text{pF}$	
$V_{\text{ICMR}}$ (Note 9)	Input Common Mode Range	$V_S = 3\text{V}$ , $V_{\text{OCM}} = 1.5\text{V}$ $V_S = 5\text{V}$ , $V_{\text{OCM}} = 2.5\text{V}$ $V_S = 10\text{V}$ , $V_{\text{OCM}} = 5\text{V}$	● ● ●	-1.5 -2.5 -5	2.1 5.1 12.6	V V V	
$\text{CMRRI}$ (Note 7)	Input Common Mode Rejection Ratio (Input Referred) $\Delta V_{\text{ICM}}/\Delta V_{\text{OSDIFF}}$	$V_S = 3\text{V}$ , $V_{\text{ICM}}$ from $-1.5\text{V}$ to $2.1\text{V}$	●	90 80	100	dB dB	
		$V_S = 5\text{V}$ , $V_{\text{ICM}}$ from $-2.5\text{V}$ to $5.1\text{V}$	●	94 85	100	dB dB	
		$V_S = 10\text{V}$ , $V_{\text{ICM}}$ from $-5\text{V}$ to $12.6\text{V}$	●	94 85	100	dB dB	
$\text{CMRRIO}$ (Note 7)	Output Common Mode Rejection Ratio (Input Referred) $\Delta V_{\text{OCM}}/\Delta V_{\text{OSDIFF}}$	$V_S = 3\text{V}$ , $V_{\text{OCM}}$ from $0.5\text{V}$ to $2.5\text{V}$	●	90 85	100	dB dB	
		$V_S = 5\text{V}$ , $V_{\text{OCM}}$ from $0.5\text{V}$ to $4.5\text{V}$	●	90 85	100	dB dB	
		$V_S = 10\text{V}$ , $V_{\text{OCM}}$ from $0.5\text{V}$ to $9.5\text{V}$	●	94 90	100	dB dB	
$V_{\text{OUT}}$	Output Voltage, High, Either Output Pin	$I_L = 0\text{mA}$ , $V_S = 3\text{V}$	●	2.78	2.89	V	
		$I_L = -5\text{mA}$ , $V_S = 3\text{V}$	●	2.74	2.85	V	
		$I_L = 0\text{mA}$ , $V_S = 5\text{V}$	●	4.77	4.87	V	
		$I_L = -5\text{mA}$ , $V_S = 5\text{V}$	●	4.73	4.83	V	
	Output Voltage, Low, Either Output Pin	$I_L = 0\text{mA}$ , $V_S = 3\text{V}$	●		0.1	0.18	V
		$I_L = 5\text{mA}$ , $V_S = 3\text{V}$	●		0.17	0.26	V
		$I_L = 0\text{mA}$ , $V_S = 5\text{V}$	●		0.11	0.19	V
		$I_L = 5\text{mA}$ , $V_S = 5\text{V}$	●		0.15	0.27	V
$I_{\text{SC}}$	Output Short-Circuit Current, Either Output Pin, Sinking	$V_S = 3\text{V}$ , Output Shorted to $1.5\text{V}$	●	12	25	mA	
		$V_S = 5\text{V}$ , Output Shorted to $2.5\text{V}$	●	13	35	mA	
		$V_S = 10\text{V}$ , Output Shorted to $5\text{V}$	●	14	40	mA	
	Output Short-Circuit Current, Either Output Pin, Sourcing	$V_S = 3\text{V}$ , Output Shorted to $1.5\text{V}$	●	25	55	mA	
		$V_S = 5\text{V}$ , Output Shorted to $2.5\text{V}$	●	27	75	mA	
		$V_S = 10\text{V}$ , Output Shorted to $5\text{V}$	●	30	90	mA	
$f_{-3\text{dB}}$	-3dB Bandwidth			25		MHz	
SR	Slew Rate	Differential $18\text{V}_{\text{P-P}}$ Output		45		$\text{V}/\mu\text{s}$	
FPBW (Note 11)	Full Power Bandwidth	$10\text{V}_{\text{P-P}}$ Output		1.4		MHz	
		$18\text{V}_{\text{P-P}}$ Output		0.8		MHz	
HD2/HD3	2nd/3rd order Harmonic Distortion Single-Ended Input	$f = 1\text{kHz}$ , $V_{\text{OUT}} = 10\text{V}_{\text{P-P}}$		-122/-125		dBc	
		$f = 10\text{kHz}$ , $V_{\text{OUT}} = 10\text{V}_{\text{P-P}}$		-114/-105		dBc	
		$f = 100\text{kHz}$ , $V_{\text{OUT}} = 10\text{V}_{\text{P-P}}$		-90/-82		dBc	



**ELECTRICAL CHARACTERISTICS** LTC6363-2 Only. The ● denotes the specifications which apply over the full operating temperature range, otherwise specifications and typical values are at  $T_A = 25^\circ\text{C}$ .  $V^+ = 10\text{V}$ ,  $V^- = 0\text{V}$ ,  $V_{\text{CM}} = V_{\text{OCM}} = V_{\text{ICM}} = 5\text{V}$ ,  $V_{\text{SHDN}} = \text{open}$ .  $V_S$  is defined as  $(V^+ - V^-)$ .  $V_{\text{OUTCM}}$  is defined as  $(V_{+\text{OUT}} + V_{-\text{OUT}})/2$ .  $V_{\text{ICM}}$  is defined as  $(V_{+\text{IN}} + V_{-\text{IN}})/2$ .  $V_{\text{OUTDIFF}}$  is defined as  $(V_{+\text{OUT}} - V_{-\text{OUT}})$ .

SYMBOL	PARAMETER	CONDITIONS	MIN	TYP	MAX	UNITS
$t_S$	Settling Time to a $8V_{\text{P-P}}$ Output Step	0.1%		420		ns
		0.01%		470		ns
		0.0015% (16-Bit)		500		ns
		4ppm (18-Bit)		810		ns
$V_{\text{OSDIFF}}$ (Note 7)	Differential Offset Voltage	$V_S = 3\text{V}$ $V_{\text{ICM}} = 1.5\text{V}$	●	25	125	$\mu\text{V}$ $\mu\text{V}$
		$V_S = 5\text{V}$ $V_{\text{ICM}} = 2.5\text{V}$	●	25	125	$\mu\text{V}$ $\mu\text{V}$
		$V_S = 10\text{V}$ $V_{\text{ICM}} = 5\text{V}$	●	25	125	$\mu\text{V}$ $\mu\text{V}$
$\Delta V_{\text{OSDIFF}}/\Delta T$ (Notes 7, 8)	Differential Offset Voltage Drift	$V_S = 3\text{V}$	●	0.45	1.25	$\mu\text{V}/^\circ\text{C}$
		$V_S = 5\text{V}$	●	0.45	1.25	$\mu\text{V}/^\circ\text{C}$
		$V_S = 10\text{V}$	●	0.45	1.25	$\mu\text{V}/^\circ\text{C}$
$G_{\text{DIFF}}$	Differential Gain	$V_{\text{OUT}} = 16V_{\text{P-P}}$		2		V/V
	Differential Gain Error		●	$\pm 0.002$	$\pm 0.0045$ $\pm 0.0075$	% %
	Differential Gain Nonlinearity			0.5		ppm
	Differential Gain Drift vs Temperature (Note 8)		●	$\pm 0.2$	$\pm 0.5$	ppm/ $^\circ\text{C}$
$e_n$ (Note 7)	Differential Input Referred Noise Voltage Density	$f = 100\text{kHz}$ , (Includes Internal Resistor Noise)		7.55		$\text{nV}/\sqrt{\text{Hz}}$
$e_{\text{nvocm}}$	Common Mode Noise Voltage Density	$f = 100\text{kHz}$		20		$\text{nV}/\sqrt{\text{Hz}}$
$R_{\text{IN}}$	Input Resistance	Common Mode		1050		$\Omega$
		Differential Mode		1400		$\Omega$
$C_{\text{IN}}$	Input Capacitance	Differential Mode		0.6		pF
		Common Mode		13.5		pF
$V_{\text{ICMR}}$ (Note 9)	Input Common Mode Range	$V_S = 3\text{V}$ , $V_{\text{OCM}} = 1.5\text{V}$	●	-0.75	1.95	V
		$V_S = 5\text{V}$ , $V_{\text{OCM}} = 2.5\text{V}$	●	-1.25	4.45	V
		$V_S = 10\text{V}$ , $V_{\text{OCM}} = 5\text{V}$	●	-2.5	10.7	V
$\text{CMRRI}$ (Note 7)	Input Common Mode Rejection Ratio (Input Referred) $\Delta V_{\text{ICM}}/\Delta V_{\text{OSDIFF}}$	$V_S = 3\text{V}$ , $V_{\text{ICM}}$ from -0.75V to 1.95V	●	90 80	106	dB dB
		$V_S = 5\text{V}$ , $V_{\text{ICM}}$ from -1.25V to 4.45V	●	94 85	112	dB dB
		$V_S = 10\text{V}$ , $V_{\text{ICM}}$ from -2.5V to 10.7V	●	94 85	112	dB dB
$\text{CMRRIO}$ (Note 7)	Output Common Mode Rejection Ratio (Input Referred) $\Delta V_{\text{OCM}}/\Delta V_{\text{OSDIFF}}$	$V_S = 3\text{V}$ , $V_{\text{OCM}}$ from 0.5V to 2.5V	●	90 85	106	dB dB
		$V_S = 5\text{V}$ , $V_{\text{OCM}}$ from 0.5V to 4.5V	●	94 90	106	dB dB
		$V_S = 10\text{V}$ , $V_{\text{OCM}}$ from 0.5V to 9.5V	●	94 90	106	dB dB

# LTC6363 Family

**ELECTRICAL CHARACTERISTICS** LTC6363-2 Only. The ● denotes the specifications which apply over the full operating temperature range, otherwise specifications and typical values are at  $T_A = 25^\circ\text{C}$ .  $V^+ = 10\text{V}$ ,  $V^- = 0\text{V}$ ,  $V_{\text{CM}} = V_{\text{OCM}} = V_{\text{ICM}} = 5\text{V}$ ,  $V_{\text{SHDN}} = \text{open}$ .  $V_S$  is defined as  $(V^+ - V^-)$ .  $V_{\text{OUTCM}}$  is defined as  $(V_{+\text{OUT}} + V_{-\text{OUT}})/2$ .  $V_{\text{ICM}}$  is defined as  $(V_{+\text{IN}} + V_{-\text{IN}})/2$ .  $V_{\text{OUTDIFF}}$  is defined as  $(V_{+\text{OUT}} - V_{-\text{OUT}})$ .

SYMBOL	PARAMETER	CONDITIONS	MIN	TYP	MAX	UNITS	
$V_{\text{OUT}}$	Output Voltage, High, Either Output Pin	$I_L = 0\text{mA}$ , $V_S = 3\text{V}$	●	2.79	2.89	V	
		$I_L = -5\text{mA}$ , $V_S = 3\text{V}$	●	2.74	2.84	V	
		$I_L = 0\text{mA}$ , $V_S = 5\text{V}$	●	4.78	4.88	V	
		$I_L = -5\text{mA}$ , $V_S = 5\text{V}$	●	4.73	4.83	V	
	Output Voltage, Low, Either Output Pin	$I_L = 0\text{mA}$ , $V_S = 10\text{V}$	●	9.76	9.85	V	
		$I_L = -5\text{mA}$ , $V_S = 10\text{V}$	●	9.67	9.81	V	
		$I_L = 0\text{mA}$ , $V_S = 3\text{V}$	●		0.09	0.18	V
		$I_L = 5\text{mA}$ , $V_S = 3\text{V}$	●		0.17	0.26	V
$I_{\text{SC}}$	Output Short-Circuit Current, Either Output Pin, Sinking	$V_S = 3\text{V}$ , Output Shorted to 1.5V	●	12	25	mA	
		$V_S = 5\text{V}$ , Output Shorted to 2.5V	●	13	35	mA	
		$V_S = 10\text{V}$ , Output Shorted to 5V	●	14	40	mA	
	Output Short-Circuit Current, Either Output Pin, Sourcing	$V_S = 3\text{V}$ , Output Shorted to 1.5V	●	25	55	mA	
		$V_S = 5\text{V}$ , Output Shorted to 2.5V	●	27	75	mA	
		$V_S = 10\text{V}$ , Output Shorted to 5V	●	30	90	mA	
$f_{-3\text{dB}}$	-3dB Bandwidth			15		MHz	
SR	Slew Rate	Differential 18V <sub>P-P</sub> Output		46		V/ $\mu\text{s}$	
FPBW (Note 11)	Full Power Bandwidth	10V <sub>P-P</sub> Output		1.4		MHz	
		18V <sub>P-P</sub> Output		0.8		MHz	
HD2/HD3	2nd/3rd order Harmonic Distortion Single-Ended Input	$f = 1\text{kHz}$ , $V_{\text{OUT}} = 10\text{V}_{\text{P-P}}$		-116/-123		dBc	
		$f = 10\text{kHz}$ , $V_{\text{OUT}} = 10\text{V}_{\text{P-P}}$		-114/-103		dBc	
		$f = 100\text{kHz}$ , $V_{\text{OUT}} = 10\text{V}_{\text{P-P}}$		-92/-81		dBc	
$t_S$	Settling Time to a 8V <sub>P-P</sub> Output Step	0.1%		430		ns	
		0.01%		470		ns	
		0.0015% (16-Bit)		480		ns	
		4ppm (18-Bit)		830		ns	

## ELECTRICAL CHARACTERISTICS

**Note 1:** Stresses beyond those listed under Absolute Maximum Ratings may cause permanent damage to the device. Exposure to any Absolute Maximum Rating condition for extended periods may affect device reliability and lifetime.

**Note 2:** Absolute Maximum input voltage for the LTC6363-0.5/LTC6363-1/LTC6363-2 is conservatively calculated assuming the worst case output voltage. For details on this calculation refer to the Input Pin Protection section.

**Note 3:** In the LTC6363, if input pins (+IN, -IN,  $V_{OCM}$  and  $\overline{SHDN}$ ) must exceed either supply voltage, the input current must be limited to less than 10mA. Additionally, if the differential input voltage exceeds 1.4V, the input current must be limited to less than 10mA. In the LTC6363-0.5/LTC6363-1/LTC6363-2 versions, the same limits apply to  $V_{OCM}$ ,  $\overline{SHDN}$  and the internal amplifier's inputs. Please see the Input Common Mode Voltage Range and Input Pin Protection sections for additional details on calculating the input voltages on the internal amplifier's inputs while in a feedback configuration.

**Note 4:** A heat sink may be required to keep the junction temperature below the absolute maximum rating when the output is shorted indefinitely.

**Note 5:** The LTC6363I and LTC6363I-0.5/LTC6363I-1/LTC6363I-2 are guaranteed functional over the operating temperature range of -40°C to 85°C. The LTC6363H and LTC6363H-0.5/LTC6363H-1/LTC6363H-2 are guaranteed functional over the operating temperature range of -40°C to 125°C.

**Note 6:** The LTC6363I and LTC6363I-0.5/LTC6363I-1/LTC6363I-2 are guaranteed to meet specified performance from -40°C to 85°C. The LTC6363H and LTC6363H-0.5/LTC6363H-1/LTC6363H-2 are guaranteed to meet specified performance from -40°C to 125°C.

**Note 7:** Differential offset voltage, differential offset voltage drift, and PSRR are referred to the internal amplifier's input (summing junction) to allow for direct comparison of gain blocks with discrete amplifiers. CMRR1, CMRRIO and voltage noise are referenced to the LTC6363-0.5, LTC6363-1 and LTC6363-2's input pins. Refer to the Test Circuits section for more details.

**Note 8:** Maximum differential offset voltage drift, input offset current drift and differential gain drift are determined by sampling typical parts. Drift is not guaranteed by test or QA sampled at this value.

**Note 9:** Input common mode range is tested by verifying that at the limits stated in the Electrical Characteristics table, the differential offset ( $V_{OSDIFF}$ ) and common mode offset ( $V_{OSCM}$ ) have not deviated by more than  $\pm 200\mu V$  and  $\pm 10mV$  respectively compared to the  $V_{ICM} = 5V$  (at  $V_S = 10V$ ),  $V_{ICM} = 2.5V$  (at  $V_S = 5V$ ) and  $V_{ICM} = 1.5V$  (at  $V_S = 3V$ ) cases.

Output common mode range is tested by verifying that at the limits stated in the Electrical Characteristics table, the common mode offset ( $V_{OSCM}$ ) has not deviated by more than  $\pm 15mV$  compared to the  $V_{OCM} = 5V$  (at  $V_S = 10V$ ),  $V_{OCM} = 2.5V$  (at  $V_S = 5V$ ) and  $V_{OCM} = 1.5V$  (at  $V_S = 3V$ ) cases.

**Note 10:** Input bias current is defined as the average of the input currents flowing into the input pins (-IN and +IN). Input Offset current is defined as the difference between the input bias currents ( $I_{OS} = I_B^+ - I_B^-$ ).

**Note 11:** Full power bandwidth is calculated from the slew rate.  

$$FPBW = SR / (2 \cdot \pi \cdot V_P)$$

## TYPICAL PERFORMANCE CHARACTERISTICS Applicable to all parts in the LTC6363 family.

**Differential Input Offset Voltage vs Temperature**

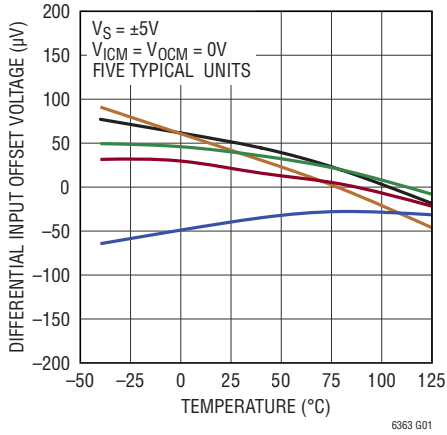

**Typical Distribution of Differential Input Offset Voltage Drift**

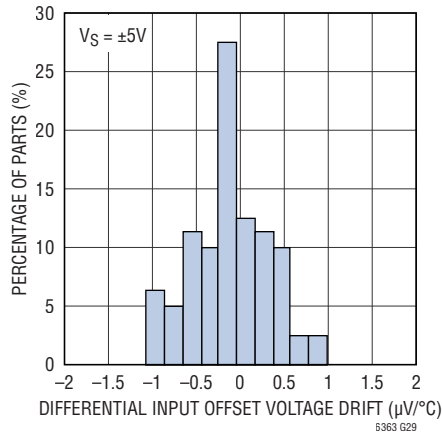

**Common Mode Offset Voltage vs Temperature**

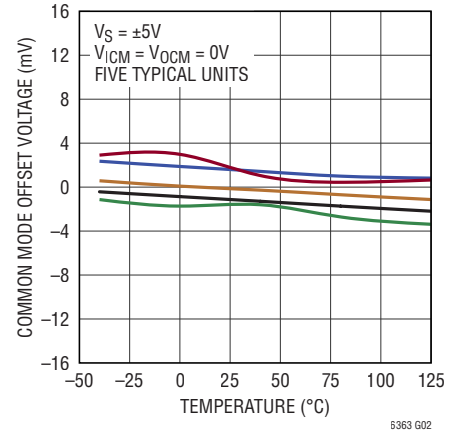

**Supply Current vs Temperature**

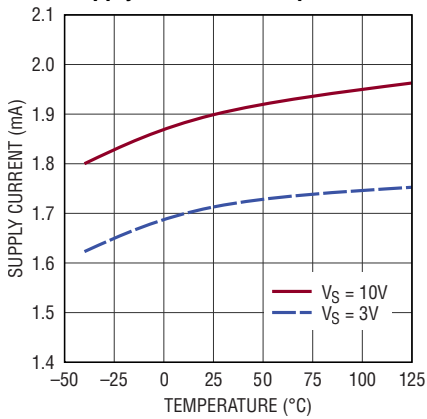

**Supply Current vs Supply Voltage**

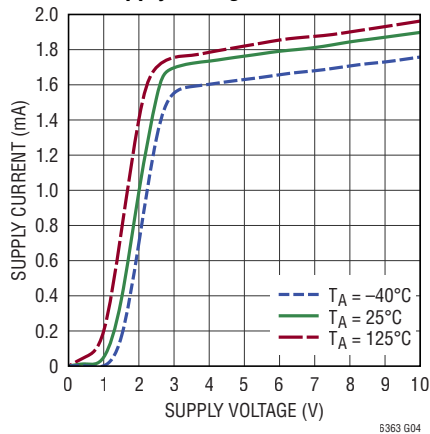

**Supply Current vs SHDN Voltage**

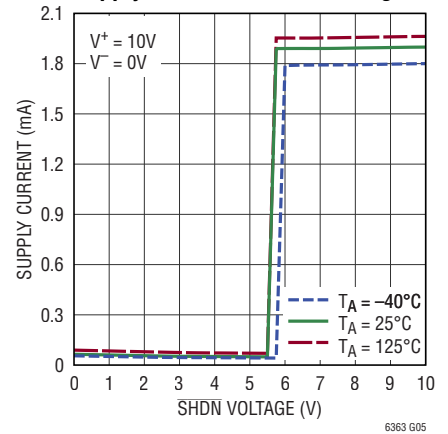

**Shutdown Supply Current vs Supply Voltage**

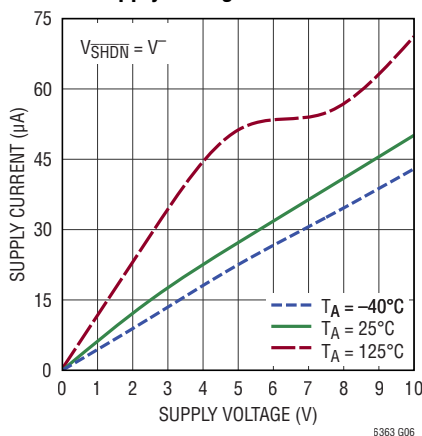

**Output Voltage Swing vs Load Current**

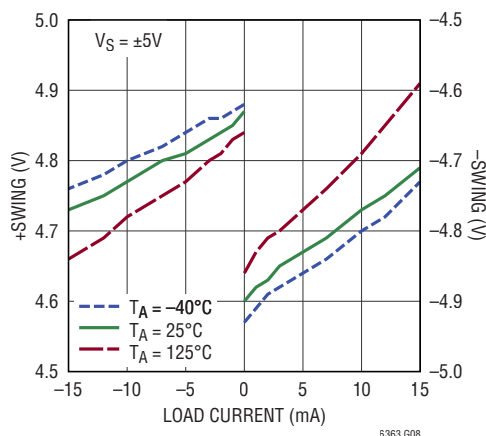

**Differential Power Supply Rejection Ratio vs Frequency**

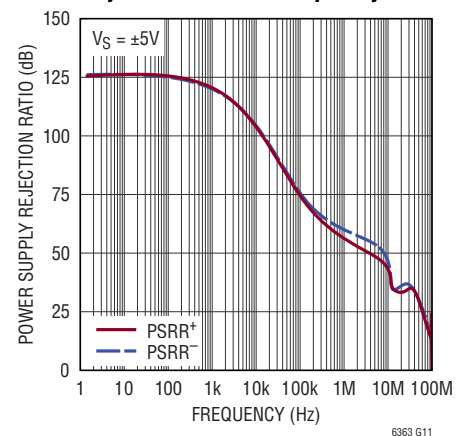

**TYPICAL PERFORMANCE CHARACTERISTICS** Applicable to the LTC6363 only.

**Differential Output Impedance vs Frequency**

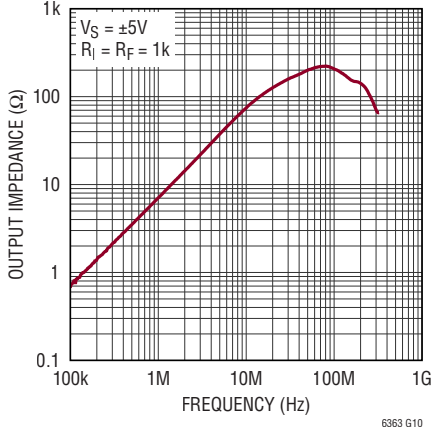

**Turn-On and Turn-Off Transient Response**

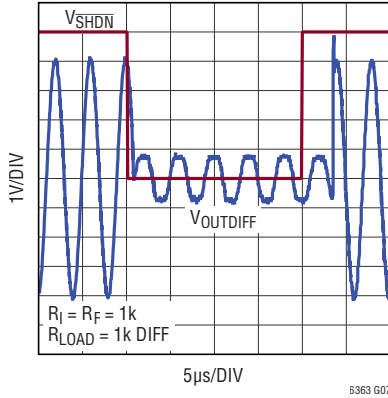

**Output Overdrive Recovery**

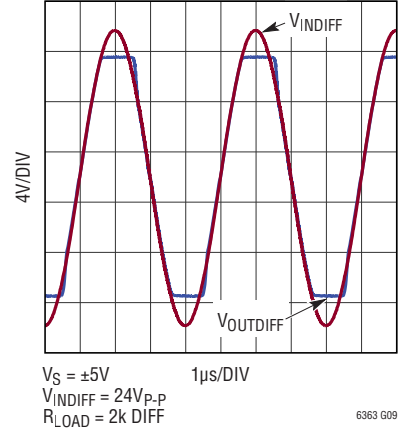

**Differential Input Offset Voltage vs Input Common Mode Voltage**

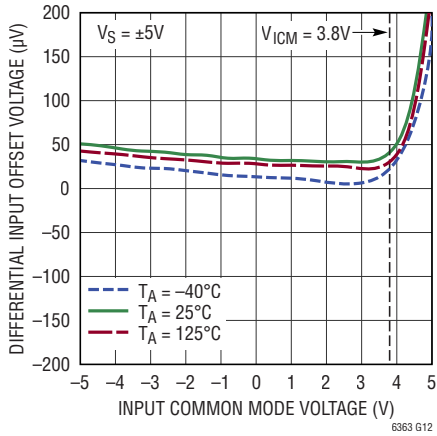

**Input Bias Current vs Input Common Mode Voltage**

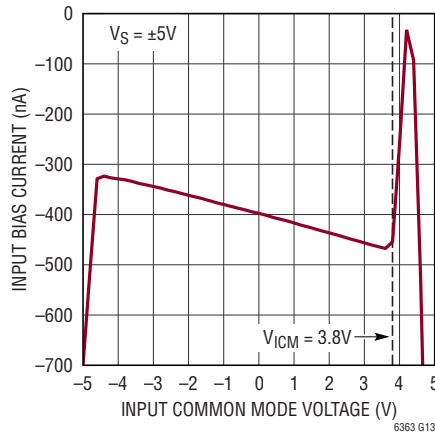

**Input Offset Current vs Temperature**

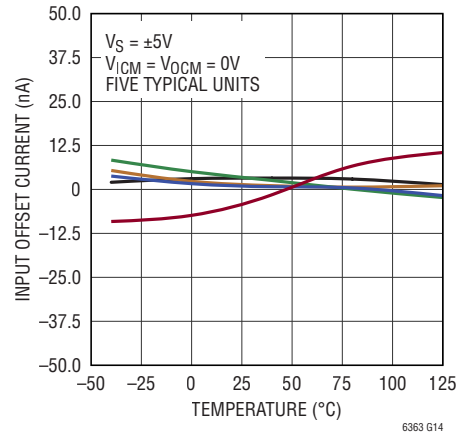

**Typical Distribution of Input Offset Current Drift**

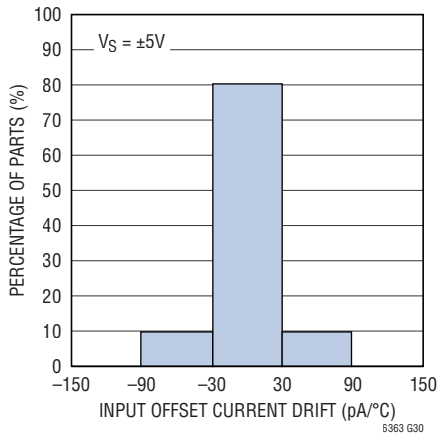

**Input Noise Density vs Frequency**

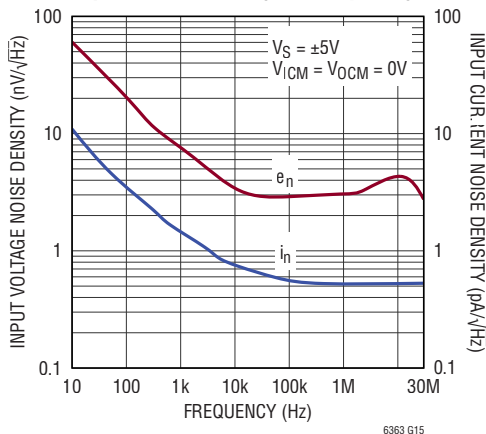

**Slew Rate vs Temperature**

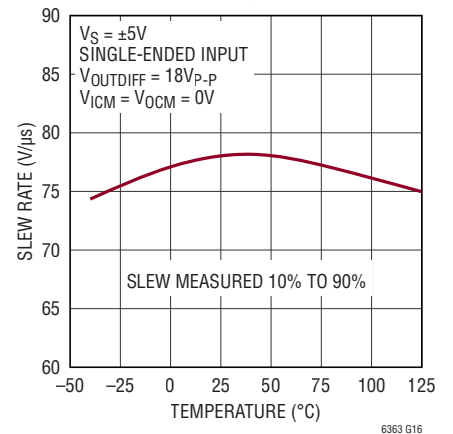

## TYPICAL PERFORMANCE CHARACTERISTICS Applicable to the LTC6363 only.

### Input Common Mode Rejection Ratio vs Frequency

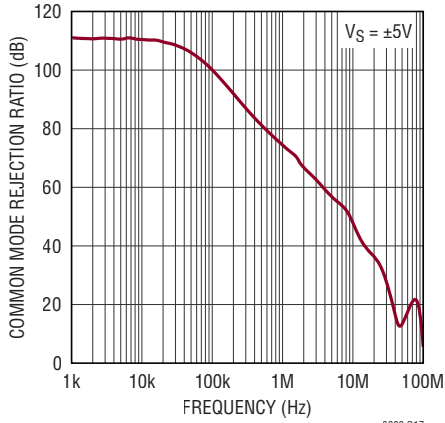

### Frequency Response vs Closed-Loop Gain

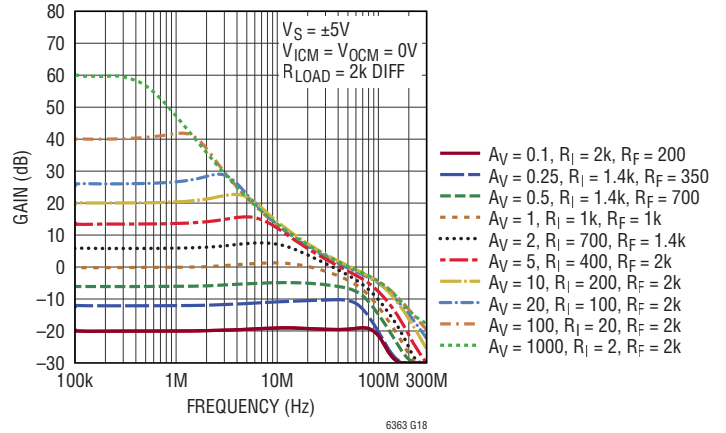

### Frequency Peaking vs Load Capacitance

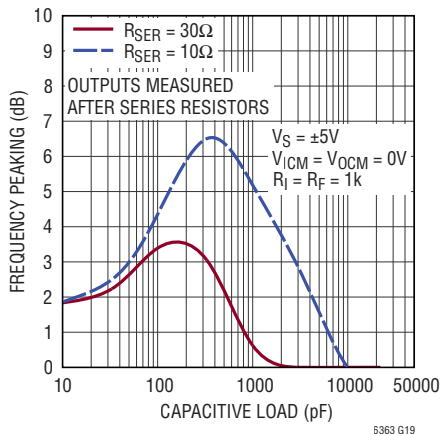

### Open-Loop Gain and Phase vs Frequency

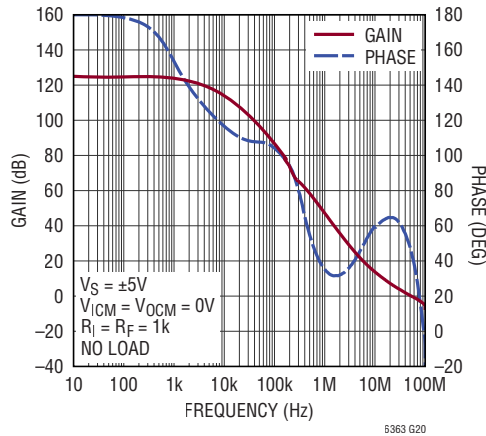

### Small Signal Step Response

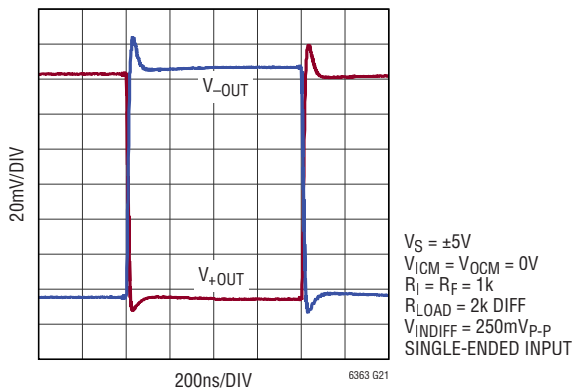

### Large Signal Step Response

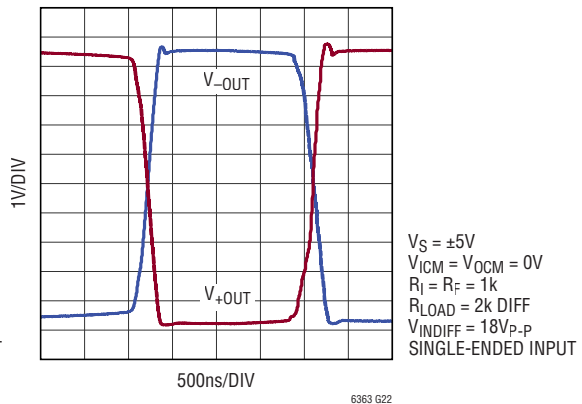

**TYPICAL PERFORMANCE CHARACTERISTICS** Applicable to the LTC6363 only.

**DC Linearity**

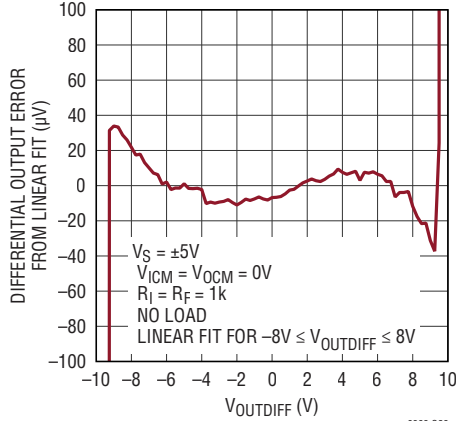

6363 G23

**Harmonic Distortion vs Frequency**

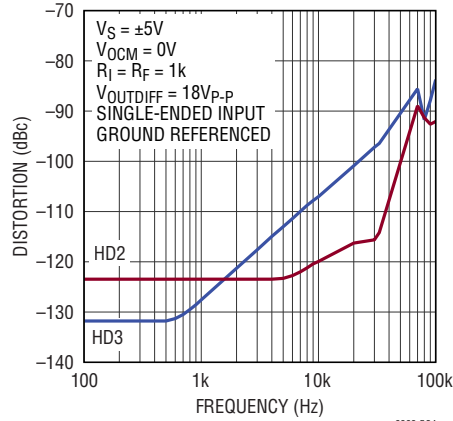

6363 G24

**Harmonic Distortion vs Input Common Mode Voltage**

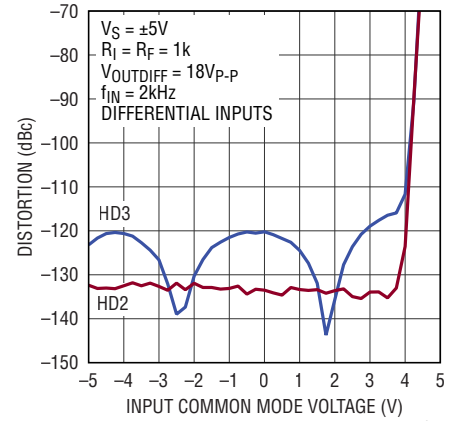

6363 G25

**Harmonic Distortion vs Output Amplitude**

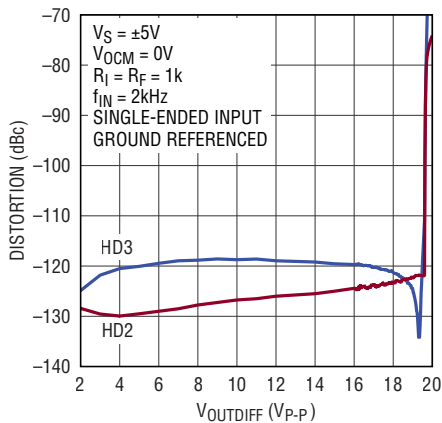

6363 G26

**Settling Time vs Output Step**

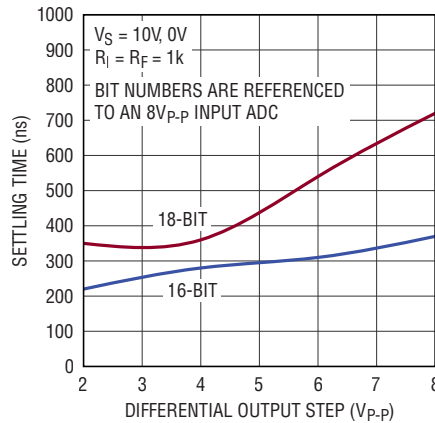

6363 G27

**Settling Time to 8V<sub>P-P</sub> Output Step**

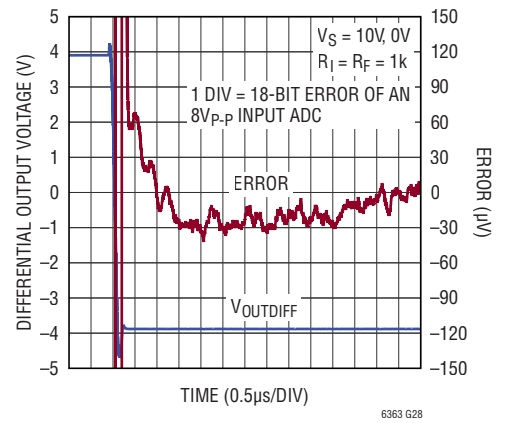

6363 G28

## TYPICAL PERFORMANCE CHARACTERISTICS Applicable to the LTC6363-0.5 only.

### Gain vs Frequency

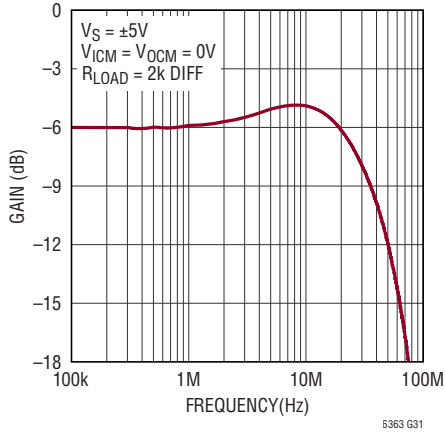

### Frequency Peaking vs Load Capacitance

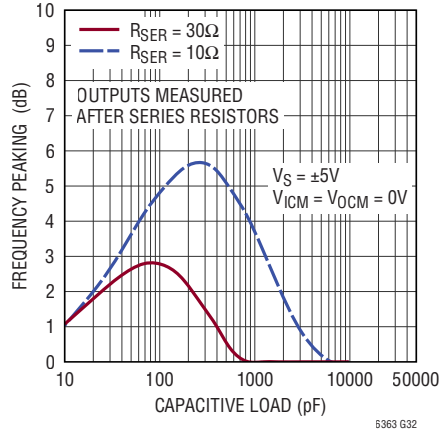

### Typical Distribution of Differential Gain Error

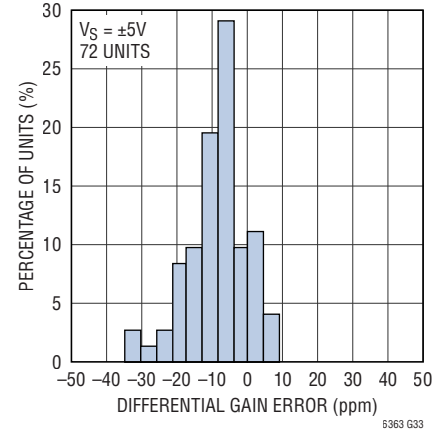

### Typical Distribution of Differential Gain Drift

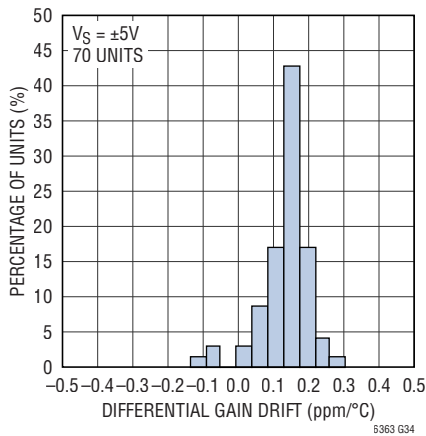

### Slew Rate vs Temperature

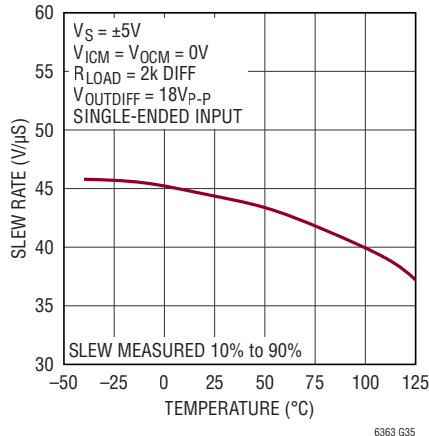

### Differential Input Offset Voltage vs Input Common Mode Voltage

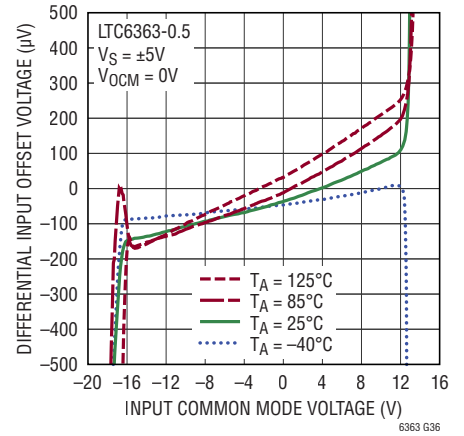

### Input Common Mode Rejection Ratio vs Frequency

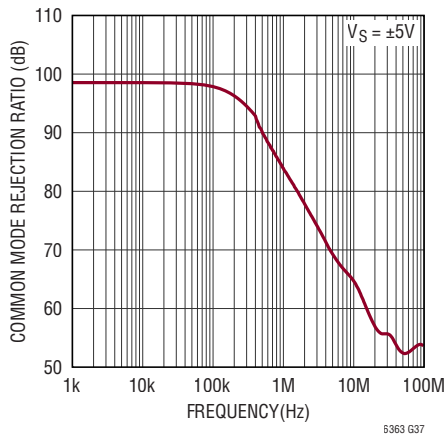

### Small Signal Step Response

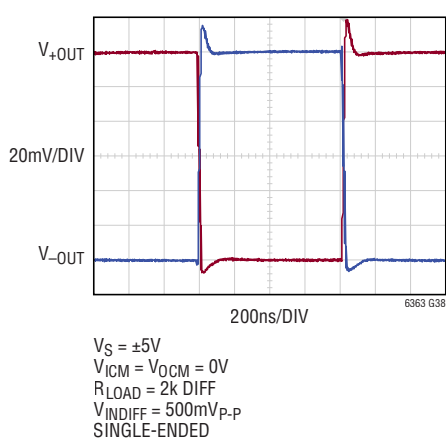

### Large Signal Step Response

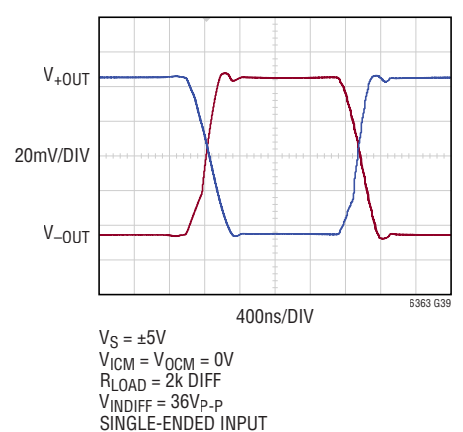



**TYPICAL PERFORMANCE CHARACTERISTICS** Applicable to the LTC6363-0.5 only.

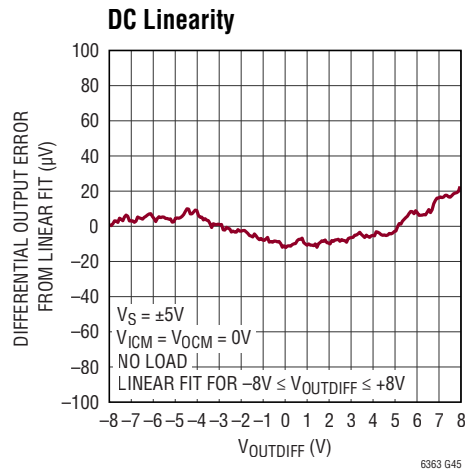
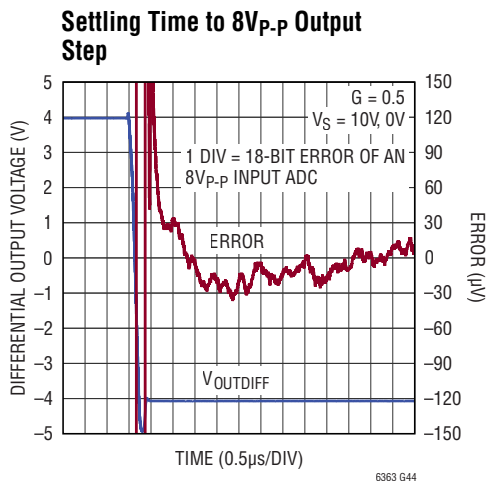
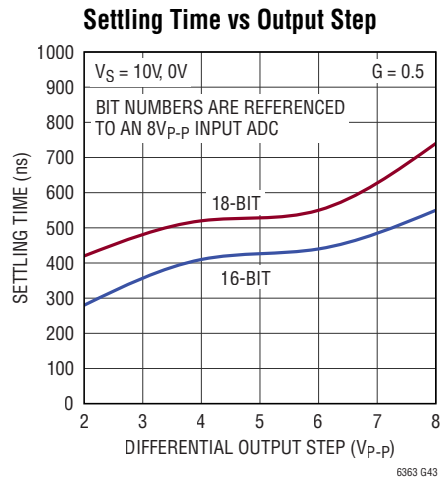
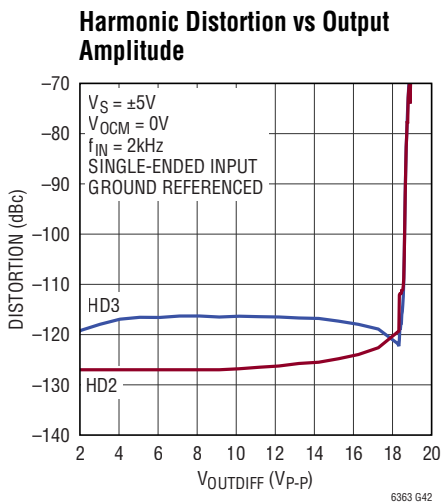
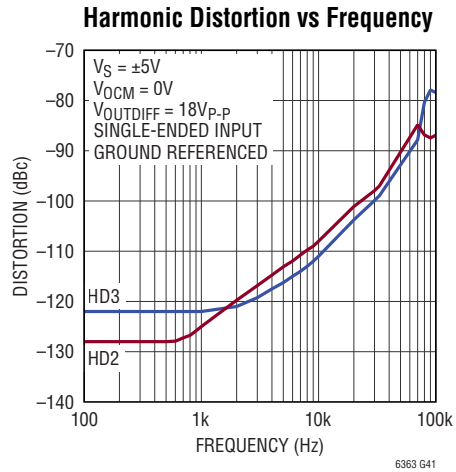
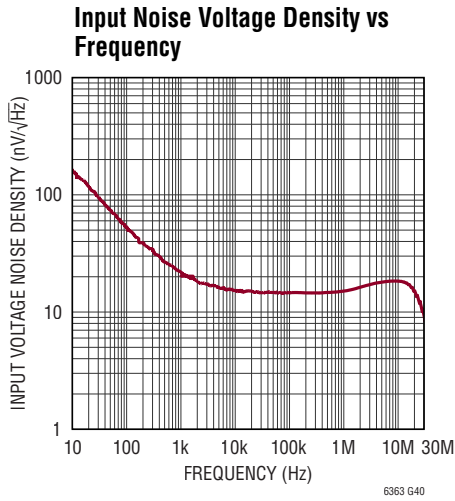

## TYPICAL PERFORMANCE CHARACTERISTICS Applicable to the LTC6363-1 only.

### Gain vs Frequency

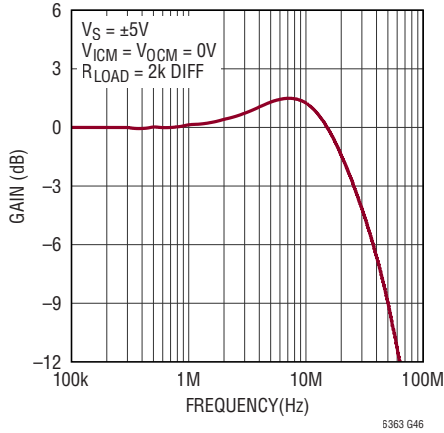

### Frequency Peaking vs Load Capacitance

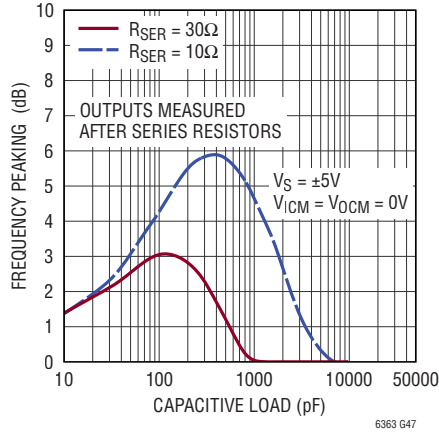

### Typical Distribution of Differential Gain Error

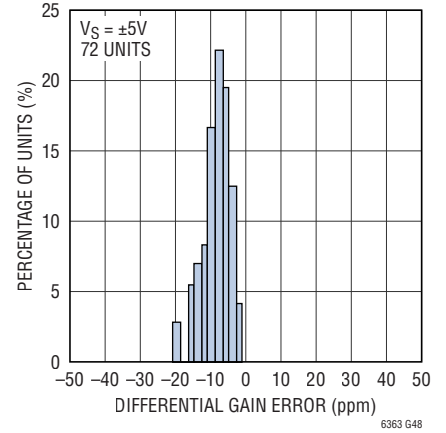

### Typical Distribution of Differential Gain Drift

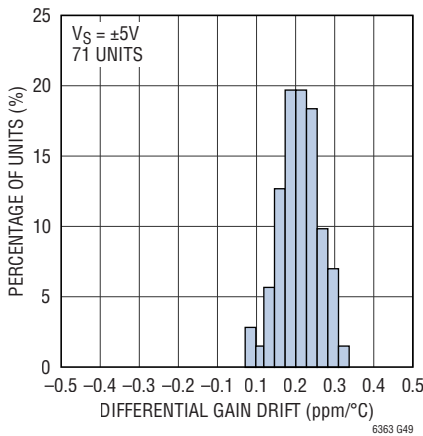

### Slew Rate vs Temperature

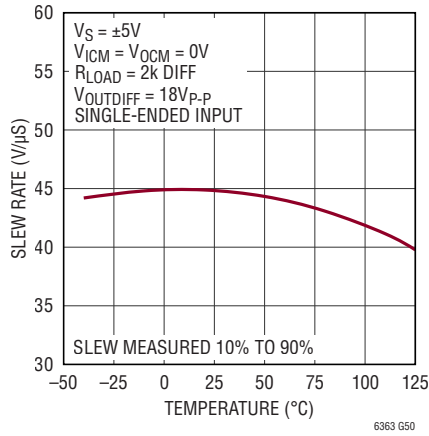

### Differential Input Offset Voltage vs Input Common Mode Voltage

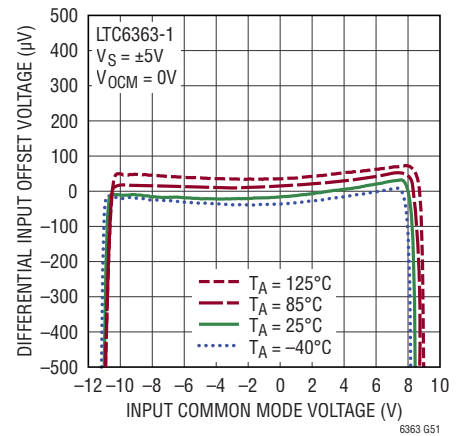

### Input Common Mode Rejection Ratio vs Frequency

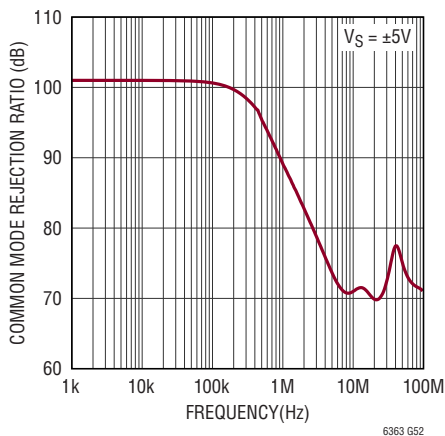

### Small Signal Step Response

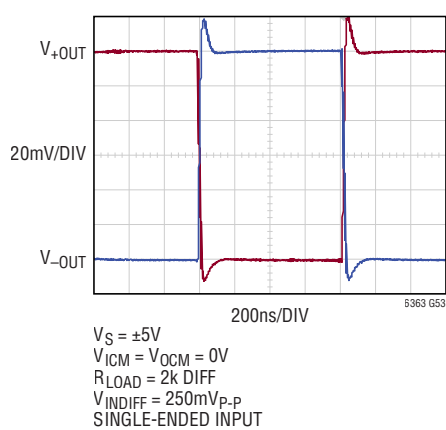

### Large Signal Step Response

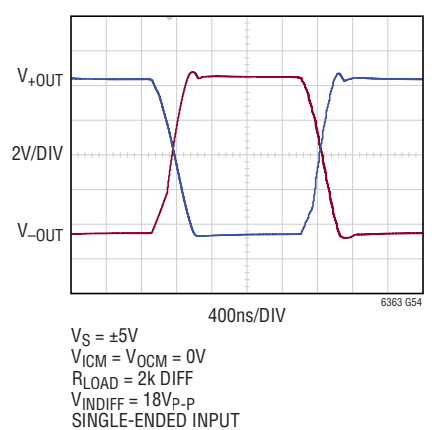

**TYPICAL PERFORMANCE CHARACTERISTICS** Applicable to the LTC6363-1 only.

**Input Noise Voltage Density vs Frequency**

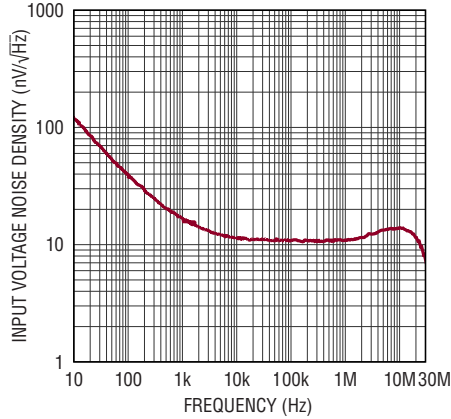

6363 G55

**Harmonic Distortion vs Frequency**

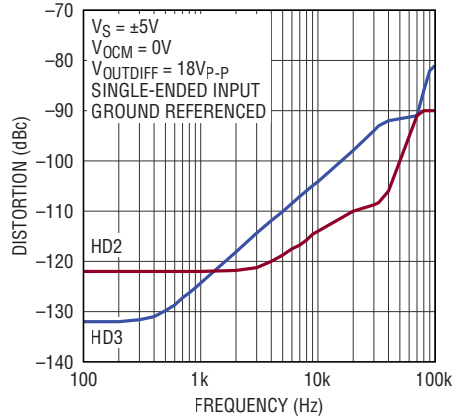

6363 G56

**Harmonic Distortion vs Output Amplitude**

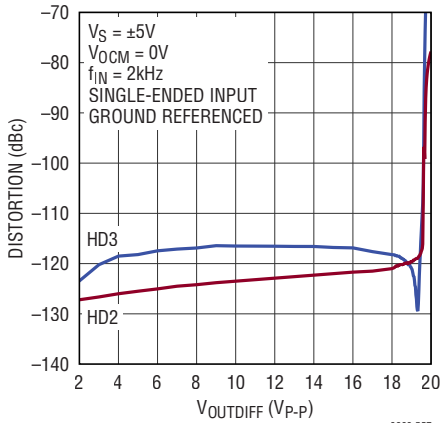

6363 G57

**Settling Time vs Output Step**

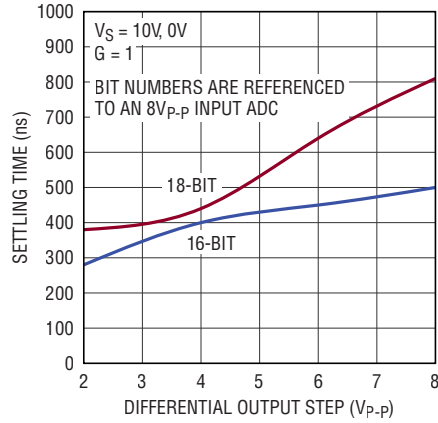

6363 G58

**Settling Time to 8Vp-p vs Output Step**

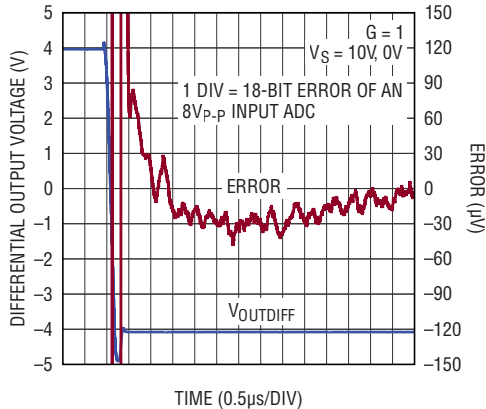

6363 G59

**DC Linearity**

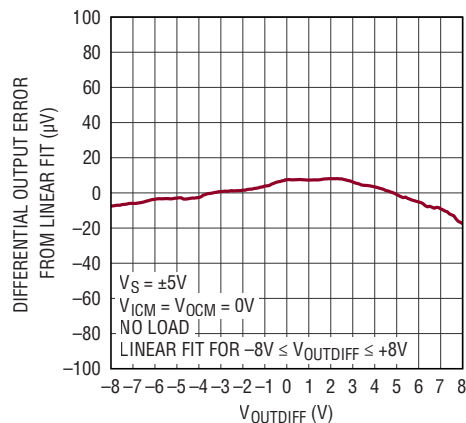

6363 G60

## TYPICAL PERFORMANCE CHARACTERISTICS Applicable to the LTC6363-2 only.

### Gain vs Frequency

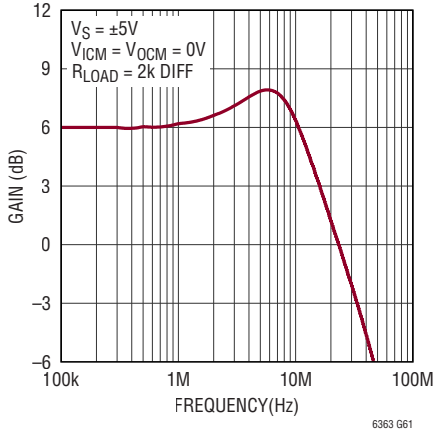

### Frequency Peaking vs Load Capacitance

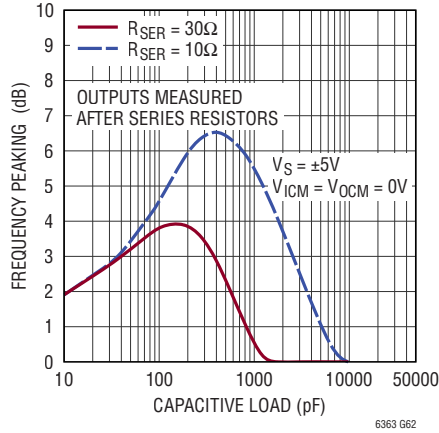

### Typical Distribution of Differential Gain Error

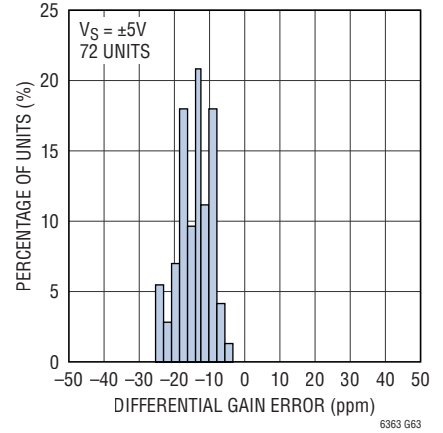

### Typical Distribution of Differential Gain Drift

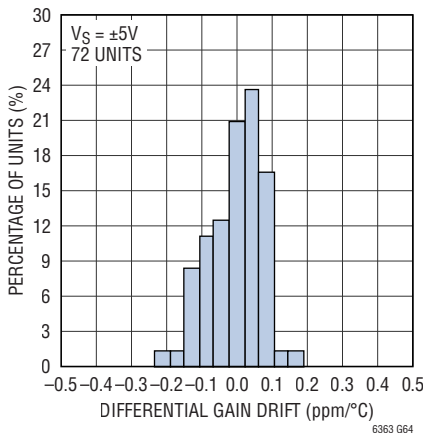

### Slew Rate vs Temperature

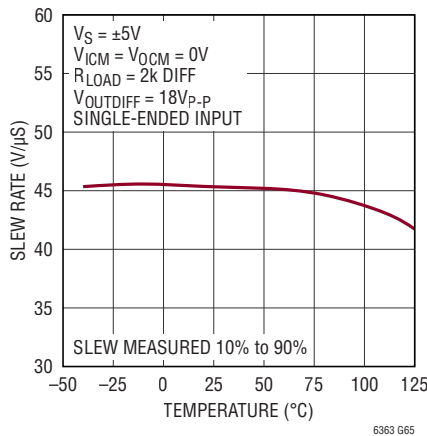

### Differential Input Offset Voltage vs Input Common Mode Voltage

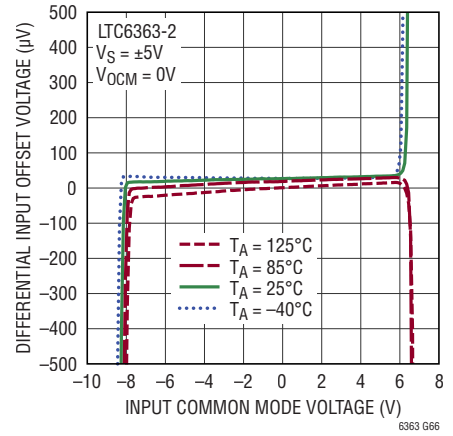

### Input Common Mode Rejection Ratio vs Frequency

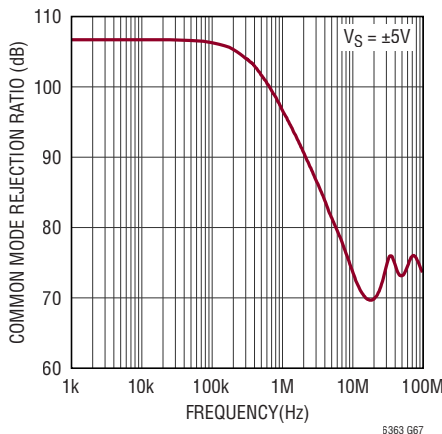

### Small Signal Step Response

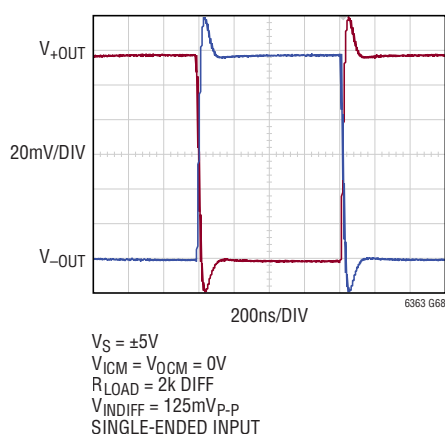

### Large Signal Step Response

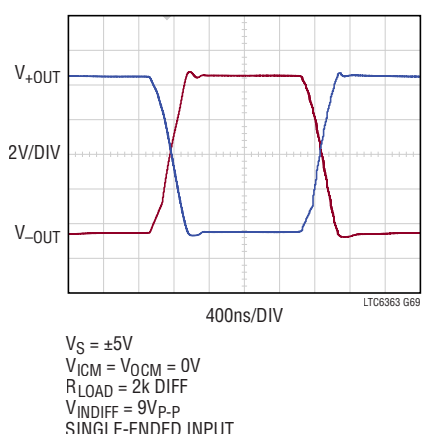

**TYPICAL PERFORMANCE CHARACTERISTICS** Applicable to the LTC6363-2 only.

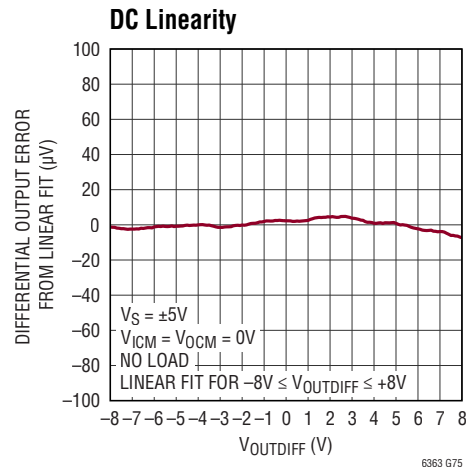
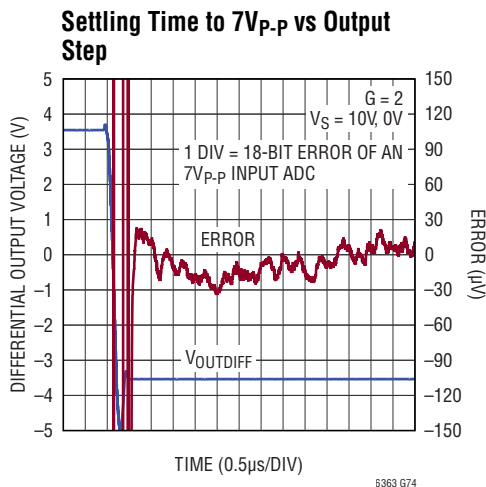
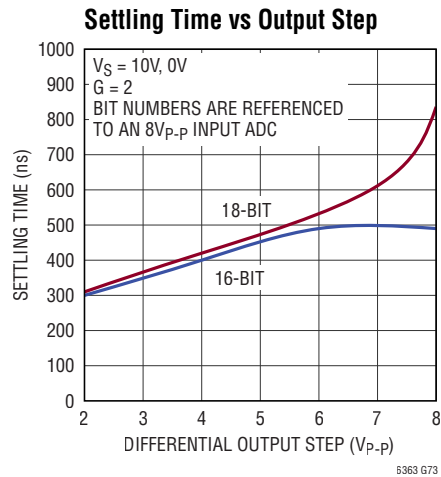
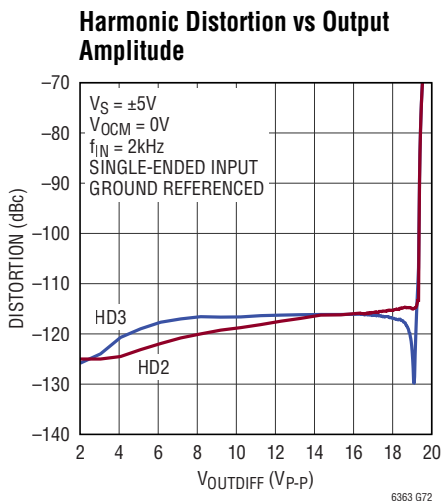
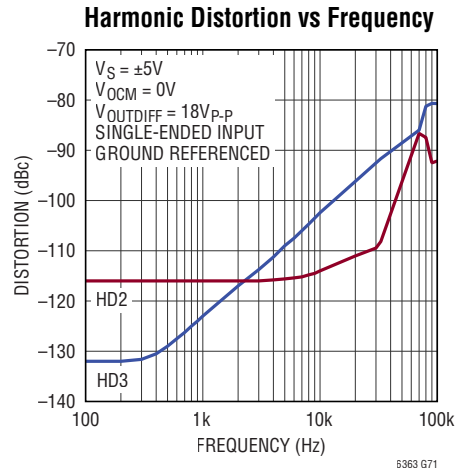
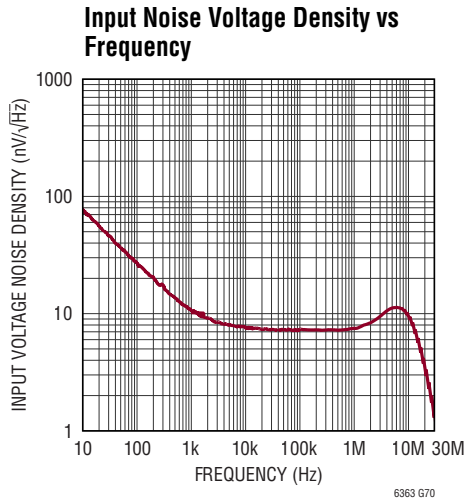

# LTC6363 Family

---

## PIN FUNCTIONS (MS8,DCB)

**–IN (Pin 1):** Inverting Input of Amplifier. In the fixed-gain LTC6363-0.5/LTC6363-1/LTC6363-2 versions, this pin connects to a precision, on-chip resistor  $R_I$ .

**$V_{OCM}$  (Pin 2):** Output Common Mode Reference Voltage. Voltage applied to this pin sets the output common mode voltage level. If left floating, an internal resistor divider creates a default voltage approximately halfway between  $V^+$  and  $V^-$ . The  $V_{OCM}$  pin should be decoupled to ground with a minimum of  $0.1\mu\text{F}$ .

**$V^+$  (Pin 3):** Positive Power Supply. Operational supply range is 2.8V to 11V when  $V^- = 0\text{V}$ .

**+OUT (Pin 4):** Positive Output Pin. Output capable of swinging rail-to-rail.

**–OUT (Pin 5):** Negative Output Pin. Output capable of swinging rail-to-rail.

**$V^-$  (Pin 6/Exposed Pad Pin 9):** Negative Power Supply. Negative supply can be 0V, or taken negative as long as  $2.8\text{V} \leq (V^+ - V^-) \leq 11\text{V}$ .

**$\overline{\text{SHDN}}$  (Pin 7):** When the  $\overline{\text{SHDN}}$  pin is floating or driven high, the LTC6363 family is in the normal (active) operating mode. When  $\overline{\text{SHDN}}$  pin is connected to  $V^-$  or driven low, the part is disabled and draws approximately  $20\mu\text{A}$  of supply current ( $V_S = 3\text{V}$ ).

**+IN (Pin 8):** Noninverting Input of Amplifier. In the fixed LTC6363-0.5/LTC6363-1/LTC6363-2 versions, this pin connects to a precision, on-chip resistor  $R_I$ .

---

## PIN FUNCTIONS (LFCSP)

**–FB (Pin 1):** Inverting Feedback Pin. The –FB pin is internally shorted out to –OUT for feedback component connection and simplified board layout.

**+IN (Pin 2):** Noninverting Input of Amplifier.

**–IN (Pin 3):** Inverting Input of Amplifier.

**+FB (Pin 4):** Noninverting Feedback Pin. The +FB pin is internally shorted out to +OUT for feedback component connection and simplified board layout.

**$V^+$  (Pins 5, 6, 7, 8):** Positive Power Supply. Operational supply range is 2.8V to 11V when  $V^- = 0\text{V}$ .

**$V_{OCM}$  (Pin 9):** Output Common Mode Reference Voltage. Voltage applied to this pin sets the output common mode voltage level. If left floating, an internal resistor divider creates a default voltage approximately halfway between  $V^+$  and  $V^-$ . The  $V_{OCM}$  pin should be decoupled to ground with a minimum of  $0.1\mu\text{F}$ .

**+OUT (Pin 10):** Positive Output Pin. Output capable of swinging rail-to-rail.

**–OUT (Pin 11):** Negative Output Pin. Output capable of swinging rail-to-rail.

**$\overline{\text{SHDN}}$  (Pin 12):** When the  $\overline{\text{SHDN}}$  pin is floating or driven high, the LTC6363 family is in the normal (active) operating mode. When  $\overline{\text{SHDN}}$  pin is connected to  $V^-$  or driven low, the part is disabled and draws approximately  $20\mu\text{A}$  of supply current ( $V_S = 3\text{V}$ ).

**$V^-$  (Pins 13, 14, 15, 16):** Negative Power Supply. Negative supply can be 0V, or taken negative as long as  $2.8\text{V} \leq (V^+ - V^-) \leq 11\text{V}$ .

**Exposed Pad (Pin 17):** Connect the exposed pad to  $V^-$  or ground.

**BLOCK DIAGRAMS**

**LTC6363 MSOP and DFN**

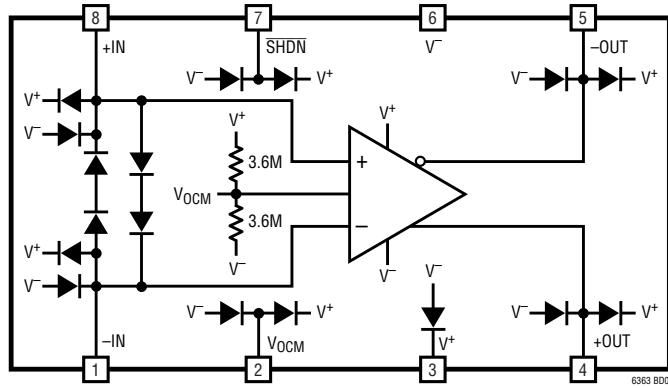

**LTC6363 LFCSP**

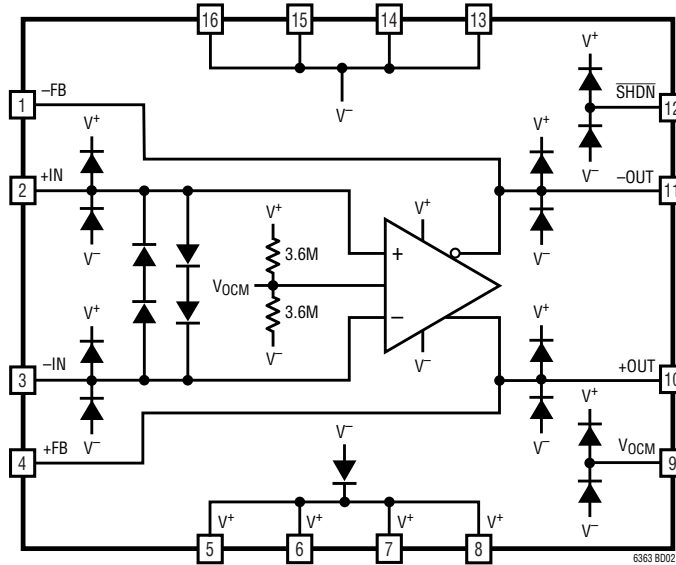

**LTC6363-0.5/ LTC6363-1/ LTC6363-2**

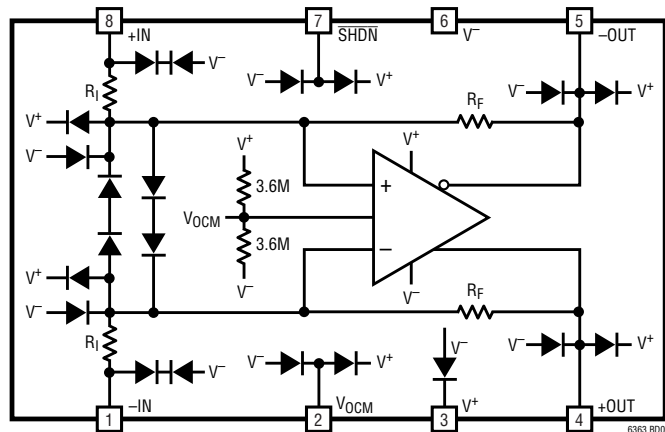

PART	R <sub>I</sub> (Ω)	R <sub>F</sub> (Ω)
LTC6363-0.5	1400	700
LTC6363-1	1050	1050
LTC6363-2	700	1400

## APPLICATIONS INFORMATION

### Functional Description

The LTC6363 family consists of four fully differential, low power, low noise, precision amplifiers. The LTC6363 is an unconstrained, fully differential amplifier, typically used with four external resistors. The LTC6363-0.5, LTC6363-1, and LTC6363-2 (gains of 0.5, 1, and 2 respectively) are fully-differential fixed gain blocks featuring precision, laser trimmed, matched internal resistors for accurate, stable gain and excellent CMRR. The entire LTC6363 family is optimized to convert a fully differential or single-ended signal to a low impedance, balanced differential output suitable for driving high performance, low power differential sigma-delta or SAR ADCs. The balanced differential nature of the amplifier also provides even-order harmonic distortion cancellation, and low susceptibility to common mode noise (e.g. power supply noise).

The outputs of the LTC6363 family are capable of swinging rail-to-rail and can source up to 90mA or sink up to 40mA of current. The LTC6363 family is optimized for high bandwidth and low power applications. Load capacitances above 50pF to ground or 25pF differentially should be decoupled with 10Ω to 50Ω of series resistance from each output to prevent oscillation or ringing.

### SHDN Pin

The LTC6363 family has a  $\overline{\text{SHDN}}$  pin which, when tied to  $V^-$  or driven to below  $V_{IL}$ , will shut down amplifier operation such that only 20μA (at  $V_S = 3V$ ) to 70μA (at  $V_S = 10V$ ) is drawn from the supplies. Pull-down circuitry should be capable of sinking at least 12μA to guarantee complete shutdown over all conditions. For normal amplifier operation, the  $\overline{\text{SHDN}}$  pin should be left floating or tied to  $V^+$  or driven to above  $V_{IH}$ .

### General Amplifier Applications

In Figure 1, the gain to  $V_{\text{OUTDIFF}}$  from  $V_{\text{INP}}$  and  $V_{\text{INM}}$  is given by:

$$V_{\text{OUTDIFF}} = V_{+\text{OUT}} - V_{-\text{OUT}} \approx \left( \frac{R_F}{R_I} \right) \cdot (V_{\text{INP}} - V_{\text{INM}})$$

Note from the previous equation, the differential output voltage ( $V_{+\text{OUT}} - V_{-\text{OUT}}$ ) is independent of input and output common mode voltages, or the voltage at the common mode pin. This makes the LTC6363 family ideally suited

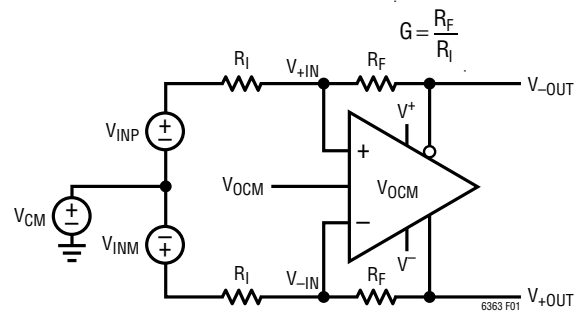

Figure 1. Definitions and Terminology

for pre-amplification, pre-attenuation, level shifting and conversion of single-ended signals to differential output signals for driving differential input ADCs or other devices.

### Output Common Mode and $V_{\text{OCM}}$ Pin

The output common mode voltage is defined as the average of the two outputs:

$$V_{\text{OUTCM}} = \left( \frac{V_{+\text{OUT}} + V_{-\text{OUT}}}{2} \right) = V_{\text{OCM}}$$

As the equation shows, the output common mode voltage is independent of the input common mode voltage, and is instead determined by the voltage on the  $V_{\text{OCM}}$  pin, by means of an internal common mode feedback loop.

The  $V_{\text{OCM}}$  input connects to the base of a PNP transistor and an internal resistor divider network. If the  $V_{\text{OCM}}$  pin is left open, the resistor divider creates a default voltage approximately halfway between  $V^+$  and  $V^-$ . The  $V_{\text{OCM}}$  pin can be overdriven to another voltage if desired for greater accuracy or flexibility. For example, when driving an ADC, if the ADC makes a reference available for setting the common mode voltage, it can be directly tied to the  $V_{\text{OCM}}$  pin, as long as the ADC is capable of driving the 1.8M input resistance presented by the  $V_{\text{OCM}}$  pin. The Electrical Characteristics table specifies the valid range that can be applied to the  $V_{\text{OCM}}$  pin ( $V_{\text{OUTCMR}}$ ).

### Input Common Mode Voltage Range

For all versions of the LTC6363, the input common mode voltage range,  $V_{\text{ICMR}}$ , specification refers to the voltage at the input pins of the part. The input common mode voltage range of the LTC6363-0.5, LTC6363-1 and LTC6363-2 are extended beyond that of the LTC6363 due to the resistor divider action of the on-chip resistors.



## APPLICATIONS INFORMATION

For LTC6363-0.5, LTC6363-1 and LTC6363-2 applications where the input is fully differential, the common mode voltage at the amplifier summing junction can be calculated using the following equation:

$$V_{ICM\_AMP} = V_{ICM} \cdot \left( \frac{G}{G+1} \right) + V_{OCM} \cdot \left( \frac{1}{G+1} \right)$$

Where G is the gain,  $V_{ICM\_AMP}$  is the common mode voltage at the amplifier's summing junction,  $V_{OCM}$  is the voltage applied to the  $V_{OCM}$  pin and  $V_{ICM}$  is the common mode voltage applied to the input pins of the LTC6363-0.5, LTC6363-1 or LTC6363-2. This equation is more useful when solved for  $V_{ICM}$ :

**Table 1. Valid Input Common Mode Voltage Range for Fixed-Gain Versions (Differential Inputs)**

PART VERSION	GAIN	SUPPLY (V)	$V_{OCM}$ (V)	$V_{ICM}$ (V)
LTC6363-0.5	0.5	3	0.5	-1 to 4.4
LTC6363-0.5	0.5	3	1.5	-3 to 2.4
LTC6363-0.5	0.5	3	2.5	-5 to 0.4
LTC6363-0.5	0.5	5	0.5	-1 to 10.4
LTC6363-0.5	0.5	5	2.5	-5 to 6.4
LTC6363-0.5	0.5	5	4.5	-9 to 2.4
LTC6363-0.5	0.5	10	0.5	-1 to 25.4
LTC6363-0.5	0.5	10	5	-10 to 16.4
LTC6363-0.5	0.5	10	9.5	-19 to 7.4
LTC6363-1	1	3	0.5	-0.5 to 3.1
LTC6363-1	1	3	1.5	-1.5 to 2.1
LTC6363-1	1	3	2.5	-2.5 to 1.1
LTC6363-1	1	5	0.5	-0.5 to 7.1
LTC6363-1	1	5	2.5	-2.5 to 5.1
LTC6363-1	1	5	4.5	-4.5 to 3.1
LTC6363-1	1	10	0.5	-0.5 to 17.1
LTC6363-1	1	10	5	-5 to 12.6
LTC6363-1	1	10	9.5	-9.5 to 8.1
LTC6363-2	2	3	0.5	-0.25 to 2.45
LTC6363-2	2	3	1.5	-0.75 to 1.95
LTC6363-2	2	3	2.5	-1.25 to 1.45
LTC6363-2	2	5	0.5	-0.25 to 5.45
LTC6363-2	2	5	2.5	-1.25 to 4.45
LTC6363-2	2	5	4.5	-2.25 to 3.45
LTC6363-2	2	10	0.5	-0.25 to 12.95
LTC6363-2	2	10	5	-2.5 to 10.7
LTC6363-2	2	10	9.5	-4.75 to 8.45

$$V_{ICM} = \frac{V_{ICM\_AMP} \cdot (G+1) - V_{OCM}}{G}$$

The minimum and maximum valid input common mode voltage can be computed using this equation by substituting for  $V_{ICM\_AMP}$  the minimum and maximum  $V_{ICMR}$  specification of the LTC6363:  $V^-$  and  $V^+ - 1.2V$  respectively. Table 1 lists various solutions to this equation.

The equation changes slightly if the LTC6363-0.5, LTC6363-1 or LTC6363-2 input is single ended since now the input common mode voltage at the amplifier's summing junction is also a function of the input signal  $V_{INP}$  (where  $V_{INM} = 0$ ):

$$V_{ICM} = \frac{V_{ICM\_AMP} \cdot (G+1) - V_{OCM} - \frac{V_{INP}}{2}}{G}$$

In summary, the common mode voltage at the input pins of the LTC6363-0.5/LTC6363-1/LTC6363-2 ( $V_{ICM}$ ) is valid if it lies within the following range:

$$\frac{V^- (G+1) - V_{OCM}}{G} \leq V_{ICM} \leq \frac{(V^+ - 1.2)(G+1) - V_{OCM}}{G}$$

For Differential Inputs

$$\frac{V^- (G+1) - V_{OCM} - \frac{V_{INP}}{2}}{G} \leq V_{ICM} \leq \frac{(V^+ - 1.2)(G+1) - V_{OCM} - \frac{V_{INP}}{2}}{G}$$

For Single-Ended Inputs ( $V_{INM} = 0$ )

### Input Pin Protection

The absolute maximum input current of the LTC6363 amplifier input pins is  $\pm 10mA$ , as specified in the Absolute Maximum Ratings. The amplifier inside the LTC6363-0.5/LTC6363-1/LTC6363-2 also has this same limitation but cannot be directly observed. Absolute maximum input voltage is specified for the LTC6363-0.5/LTC6363-1/LTC6363-2 using the following equations:

$$V^- - 10mA \cdot R_I - \frac{(V_{OUT} - V^- + 0.3)}{G} - 0.3 \text{ to}$$

$$V^+ + 10mA \cdot R_I + \frac{(V^+ + 0.3 - V_{OUT})}{G} + 0.3$$

## APPLICATIONS INFORMATION

The output voltage is a variable in these equations because it affects how much current is flowing in  $R_F$ . This current also flows in  $R_I$  and increases the voltage which can be applied to the input without exceeding the 10mA limit on the amplifier's inputs. The absolute maximum input voltage is specified conservatively, assuming the output voltage is at  $V^+$  for the positive limit and  $V^-$  for the negative limit. This simplifies the equations:

$$V^- - 10\text{mA} \cdot R_I - 0.3 \cdot \left(1 + \frac{1}{G}\right) \text{ to}$$

$$V^+ + 10\text{mA} \cdot R_I + 0.3 \cdot \left(1 + \frac{1}{G}\right)$$

### Input Impedance and Loading Effects

The low frequency input impedance looking into the  $V_{INP}$  or  $V_{INM}$  input of Figure 1 depends on how the inputs are driven. For fully differential input sources ( $V_{INP} = -V_{INM}$ ), the input impedance seen at either input is simply:

$$R_{INP} = R_{INM} = R_I$$

For single-ended inputs, due to the signal imbalance at the input, the input impedance increases over the balanced differential case. The input impedance looking into either input is:

$$R_{INP} = R_{INM} = \frac{R_I}{1 - \left(\frac{1}{2}\right) \cdot \left(\frac{R_F}{R_I + R_F}\right)}$$

Input signal sources with non-zero impedances can also cause feedback imbalance between the pair of feedback networks. For the best performance, it is recommended that the input source impedance be compensated. If impedance matching is required at the source, a termination resistor  $R_1$  should be chosen (see Figure 2) such that:

$$R_1 = \frac{R_{INM} \cdot R_S}{R_{INM} - R_S}$$

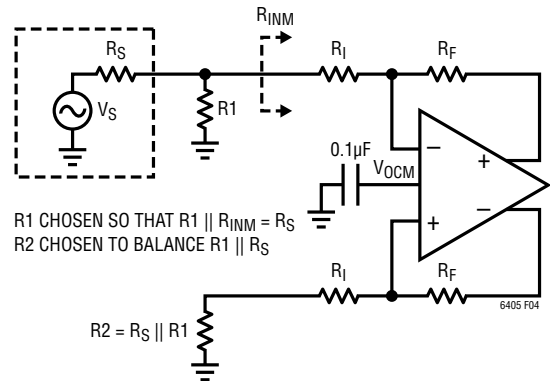

**Figure 2. Optimal Compensation for Signal Source Impedance**

According to Figure 2, the input impedance looking into the differential amp ( $R_{INM}$ ) reflects the single-ended source case, given above. Also,  $R_2$  is chosen as:

$$R_2 = R_1 || R_S = \frac{R_1 \cdot R_S}{R_1 + R_S}$$

### Effects of Resistor Pair Mismatch

Figure 3 shows a circuit diagram which takes into consideration resistor mismatch. Often, resistor mismatch limits CMRR well below amplifier specifications. Assuming infinite open-loop gain, the differential output relationship is given by the equation:

$$V_{OUT(DIFF)} = V_{+OUT} - V_{-OUT} \\ \approx V_{INDIFF} \cdot \frac{R_F}{R_I} + V_{OCM} \cdot \frac{\Delta\beta}{\beta_{AVG}} - V_{OCM} \cdot \frac{\Delta\beta}{\beta_{AVG}}$$

where  $R_F$  is the average of  $R_{F1}$  and  $R_{F2}$ , and  $R_I$  is the average of  $R_{I1}$  and  $R_{I2}$ .

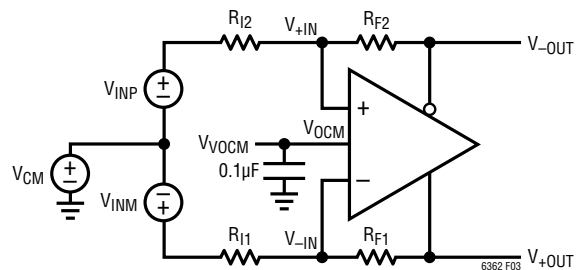

**Figure 3. Real-World Application with Feedback Resistor Pair Mismatch**

## APPLICATIONS INFORMATION

$\beta_{AVG}$  is defined as the average feedback factor from the outputs to their respective inputs:

$$\beta_{AVG} = \frac{1}{2} \cdot \left( \frac{R_{I1}}{R_{I1} + R_{F1}} + \frac{R_{I2}}{R_{I2} + R_{F2}} \right)$$

$\Delta\beta$  is defined as the difference in the feedback factors:

$$\Delta\beta = \frac{R_{I2}}{R_{I2} + R_{F2}} - \frac{R_{I1}}{R_{I1} + R_{F1}}$$

Here,  $V_{CM}$  and  $V_{INDIFF}$  are defined as the average and the difference of the two input voltages  $V_{INP}$  and  $V_{INM}$ , respectively:

$$V_{CM} = \frac{V_{INP} + V_{INM}}{2}$$

$$V_{INDIFF} = V_{INP} - V_{INM}$$

When the feedback ratios mismatch ( $\Delta\beta$ ), common mode to differential conversion occurs. Setting the differential input to zero ( $V_{INDIFF} = 0$ ), the degree of common mode to differential conversion is given by the equation:

$$V_{OUTDIFF} \approx (V_{CM} - V_{OCM}) \cdot \Delta\beta / \beta_{AVG}$$

In general, the degree of feedback pair mismatch is a source of common mode to differential conversion of both signals and noise. For instance, Table 2 shows the worst-case, resistor limited CMRR of the LTC6363 amplifier configured in a gain of 1 using external resistors.

Table 2.

Tolerance	CMRR
5%	20dB
1%	34dB
0.1%	54dB
0.01%	74dB
LT5400	86dB
0.001%	94dB

The LTC6363-0.5/LTC6363-1/LTC6363-2 versions exhibit superior DC CMRR due to precise on-chip resistors to realize their intended gains. For example, the LTC6363-1 exhibits a DC CMRR of 100dB, which is equivalent to using resistors of 0.0005% tolerance and eliminates the additional cost and area associated with discrete components.

A low impedance ground plane should be used as a reference for both the input signal source and the  $V_{OCM}$  pin.

### Noise

The LTC6363's differential input referred voltage and current noise densities are  $2.9\text{nV}/\sqrt{\text{Hz}}$  and  $0.55\text{pA}/\sqrt{\text{Hz}}$ , respectively. In addition to the noise generated by the amplifier, the surrounding feedback resistors also contribute noise. A simplified noise model is shown in Figure 4. The output noise generated by both the amplifier and the feedback components is given by the equation:

$$e_{no} = \sqrt{\left[ e_{ni} \cdot \left( 1 + \frac{R_F}{R_I} \right) \right]^2 + 2 \cdot (i_n \cdot R_F)^2 + 2 \cdot \left[ e_{nRI} \cdot \frac{R_F}{R_I} \right]^2 + 2 \cdot e_{nRF}^2}$$

For example, if  $R_F = R_I = 1\text{k}$ , the output noise of the circuit  $e_{no} = 10\text{nV}/\sqrt{\text{Hz}}$ .

If the circuits surrounding the amplifier are well balanced, common mode noise ( $e_{nVOCM}$ ) does not appear in the differential output noise equation given above.

The LTC6363's input referred voltage noise contributes the equivalent noise of a  $510\Omega$  resistor. When the feedback network is comprised of resistors whose values are larger than this, the output noise is resistor noise and amplifier current noise dominant. For feedback networks consisting

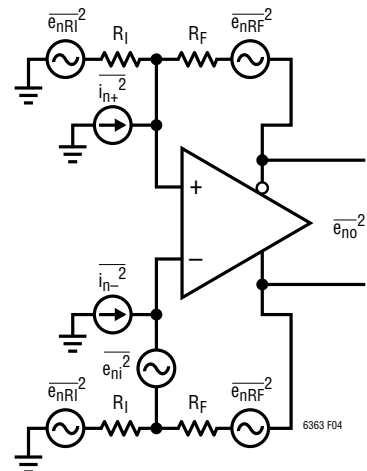

Figure 4. Simplified Noise Model

## APPLICATIONS INFORMATION

of resistors with values smaller than  $510\Omega$ , the output noise is voltage noise dominant.

Lower resistor values always result in lower noise at the penalty of increased distortion due to increased loading of the feedback network on the output. Higher resistor values will result in higher output noise, but typically improved distortion due to less loading on the output.

Keep in mind that in the Electrical Characteristics table the voltage noise specification for the LTC6363-0.5/LTC6363-1/LTC6363-2 includes the contributions of the on chip  $R_F$  and  $R_I$  resistances. These resistance values were chosen to optimize noise and distortion performance while interfacing with SAR ADCs.

### GBW vs $f_{-3dB}$

Gain-bandwidth product (GBW) and  $-3dB$  frequency ( $f_{-3dB}$ ) have been specified in the Electrical Characteristics table as two different metrics for the speed of the LTC6363 family. GBW is obtained by measuring the open-loop gain of the amplifier at a specific frequency ( $f_{TEST}$ ), then calculating  $gain \cdot f_{TEST}$ . GBW is a parameter that depends only on the internal design and compensation of the amplifier and is a suitable metric to specify the inherent speed capability of the internal amplifier. For this reason, GBW is specified in the Electrical Characteristics table only for the LTC6363.

Of more practical interest,  $f_{-3dB}$  is the frequency at which the closed-loop gain is 3dB lower than its low frequency value. The value of  $f_{-3dB}$  depends on the speed of the internal amplifier as well as the feedback factor. Thus the  $f_{-3dB}$  frequency has been specified in the Electrical Characteristics table for the LTC6363 as well as LTC6363-0.5/LTC6363-1/LTC6363-2 versions.

In most amplifiers, the open-loop gain response exhibits a conventional single-pole roll-off for most of the frequencies before the unity-gain crossover frequency, and the GBW and unity-gain frequency are close to each other. However, the LTC6363 family is intentionally compensated in such a way that its GBW is significantly larger than its  $f_{-3dB}$  in a closed loop gain of 1. This means that at lower frequencies where the amplifier inputs generally operate, the amplifier's gain and thus the feedback loop gain is

larger. This further linearizes the amplifier and improves distortion at those frequencies.

### Feedback Capacitors

When the combination of parasitic capacitances (device + PCB) at the LTC6363's inputs form a pole whose frequency lies within the closed-loop bandwidth of the amplifier, a capacitor ( $C_F$ ) can be added in parallel with the external feedback resistors ( $R_F$ ) to cancel the degradation on stability.  $C_F$  will typically be at least equal to  $C_{IN,CM}$ .  $C_F$  should be chosen such that it generates a zero at a frequency close to the frequency of the pole. The LTC6363-0.5/LTC6363-1/LTC6363-2 versions are internally stable so no  $C_F$  is needed.

### Board Layout and Bypass Capacitors

For single supply applications, it is recommended that high quality  $0.1\mu F$  ceramic bypass capacitors be placed directly between the  $V^+$  and the  $V^-$  pin with short connections. The  $V^-$  pin should be tied directly to a low impedance ground plane with minimal routing. For dual (split) power supplies, it is recommended that additional high quality  $0.1\mu F$  ceramic capacitors be used to bypass  $V^+$  to ground and  $V^-$  to ground, again with minimal routing. Small geometry (e.g., 0603) surface mount ceramic capacitors have a much higher self-resonant frequency than leaded capacitors, and perform best with the LTC6363 family.

To prevent degradation in stability response, it is highly recommended that any stray capacitance at the LTC6363's input pins, +IN and -IN, be kept to an absolute minimum by keeping printed circuit connections as short as possible.

At the inputs of the LTC6363-0.5/LTC6363-1/LTC6363-2 versions, any source impedance effectively sums with the  $R_I$ . Any parasitic resistance should be minimized and balanced to preserve gain accuracy and common mode rejection performance.

At the output, always keep in mind the differential nature of the LTC6363 family, because it is critical that the load impedances seen by both outputs and feedback pins (stray or intended), be as balanced and symmetric as possible. This will help preserve the balanced operation of the LTC6363 family that minimizes the generation of

## APPLICATIONS INFORMATION

even-order harmonics and maximizes the rejection of common mode signals and noise.

The  $V_{OCM}$  pin should be bypassed to the ground plane with a high quality 0.1 $\mu$ F ceramic capacitor. This will prevent common mode signals and noise on this pin from being inadvertently converted to differential signals and noise by impedance mismatches both externally and internally to the IC.

### Power Dissipation

Due to the wide supply voltage range, it is possible for the LTC6363 family to exceed the maximum junction temperature under certain conditions. Maximum junction temperature ( $T_J$ ) is calculated from the ambient temperature ( $T_A$ ) and power dissipation ( $P_D$ ) as follows:  $T_J = T_A + (P_D \cdot \theta_{JA})$ . The power dissipation in the IC is a function of the supply voltage, output voltage and the load, input and feedback resistances. For a given supply voltage, the worst-case power dissipation,  $P_{D(MAX)}$ , occurs at the maximum quiescent supply current and at an output voltage which is half of either supply voltage (or the maximum swing if it is less than half the supply voltage). In this condition, the LTC6363 will supply current to the load resistors and the input and feedback resistors,  $R_I$  and  $R_F$ .  $P_{D(MAX)}$  is given by:

$$P_{D(MAX)} = (V^+ - V^-) (I_{S(MAX)}) + 2 \cdot \frac{\left(\frac{V^+}{2}\right)^2}{R_L} + 2 \cdot \frac{\left(\frac{V^+}{2} \left(1 + \frac{R_I}{R_F}\right)\right)^2}{R_I + R_F}$$

Example: An LTC6363HMS8 in the 8-Lead MSOP package has a thermal resistance of  $\theta_{JA} = 273^\circ\text{C/W}$ . Operating on  $\pm 5\text{V}$  supplies, with  $R_I = R_F = 500\Omega$ , and driving a 500 $\Omega$  load to ground at each output, the worst-case power dissipation is given by:

$$P_{D(MAX)} = (10\text{V})(2.2\text{mA}) + 2 \cdot \frac{(2.5\text{V})^2}{500\Omega} + 2 \cdot \frac{(5\text{V})^2}{1000\Omega} = 97\text{mW}$$

In this example, the maximum ambient temperature that the part is allowed to operate is:

$$T_A = T_J - (P_{D(MAX)} \cdot 273^\circ\text{C/W})$$

$$T_A = 150^\circ\text{C} - (97\text{mW})(273^\circ\text{C/W}) = 123.5^\circ\text{C}$$

To operate the device at a higher ambient temperature for the same conditions, use the LTC6363 in the 8-Lead DFN package.

### Interfacing to ADCs

When driving an ADC, an additional passive filter should be used between the outputs of the LTC6363 family and the inputs of the ADC. Depending on the application, a single-pole RC filter will often be sufficient. The sampling process of ADCs creates a charge transient due to the switching in of the ADC sampling capacitor. This momentarily creates high frequency current pulses at the output of the amplifier as charge is transferred between amplifier and sampling capacitor. The amplifier must recover and settle from this load transient before the acquisition period has ended for a valid representation of the input signal. The RC network between the outputs of the driver and the inputs of the ADC decouples this sampling transient (see Figure 5). The capacitance serves to provide the bulk of the charge during the sampling process, and the two resistors at the outputs of the LTC6363 family are used to dampen and attenuate any charge injected by the ADC. Additionally, the RC filter band limits broadband output noise.

The selection of an appropriate filter depends on the specific ADC, and the following procedure is suggested for choosing filter component values. Begin by selecting an appropriate RC time constant for the input signal. Generally, longer time constants improve SNR at the expense of settling time. Output transient settling to 20-bit accuracy will require nearly 14 RC time constants to completely settle. To select the resistor value, remember the resistors in the decoupling network should be at least 10 $\Omega$ . Keep in mind that these resistors also serve to decouple the LTC6363 family outputs from load capacitance. Too large of a resistor will leave insufficient settling time. Too small of a resistor will not properly dampen the load transient of the sampling process, prolonging the time required for

## APPLICATIONS INFORMATION

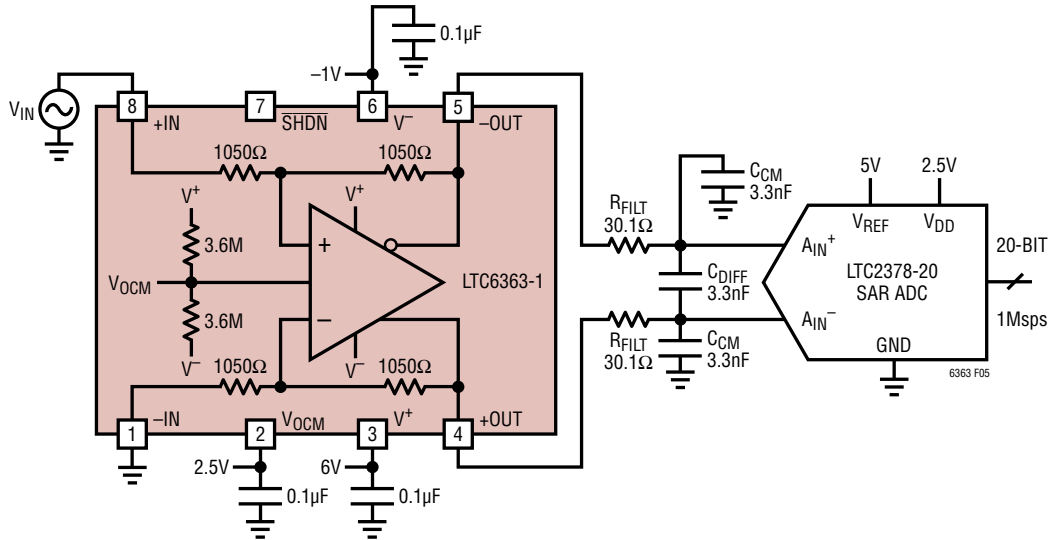

**Figure 5. Recommended Interface Solution for Driving the LTC2378-20 SAR ADC**

settling. For lowest distortion, choose capacitors with low dielectric absorption (such as a COG multilayer ceramic capacitor). In general, large capacitor values attenuate the fixed nonlinear charge kickback; however very large capacitor values will detrimentally load the driver at the desired input frequency and cause driver distortion. Smaller input swings will allow for larger filter capacitor values due to decreased loading demands on the driver. This property may be limited by the particular input amplitude dependence of differential nonlinear charge kickback for the specific ADC.

In some applications, placing series resistors at the inputs of the ADC may further improve distortion performance.

These series resistors function with the ADC sampling capacitor to filter potential ground bounce or other high speed sampling disturbances. Additionally, the resistors limit the rise time of residual filter glitches that manage to propagate to the driver outputs. Restricting possible glitch propagation rise time to within the small signal bandwidth of the driver enables less disturbed output settling.

For the specific application of LTC6363 driving the LTC2378-20 SAR ADC, the recommended component values of the RC filter are provided in Figure 5. These component values are chosen for optimal distortion and noise performance.



**TEST CIRCUITS** Noise gain =  $G_N = 1 + \frac{R_F}{R_I}$ , closed loop gain =  $G = \frac{R_F}{R_I}$

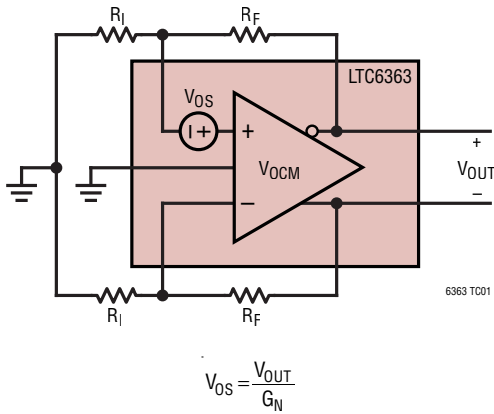

**Figure 6. Specified LTC6363  $V_{OS}$  Is Referred to the Summing Junction**

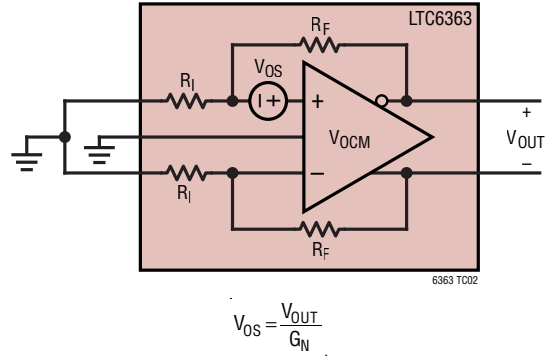

**Figure 7. Specified LTC6363-0.5, LTC6363-1 and LTC6363-2  $V_{OS}$  Is Referred to the Summing Junction**

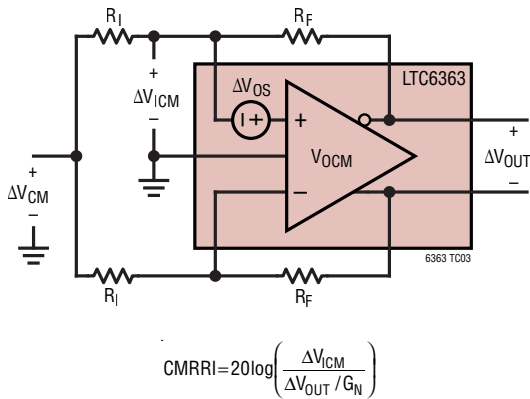

**Figure 8. Specified LTC6363 CMRRI Is Referred to the Summing Junction**

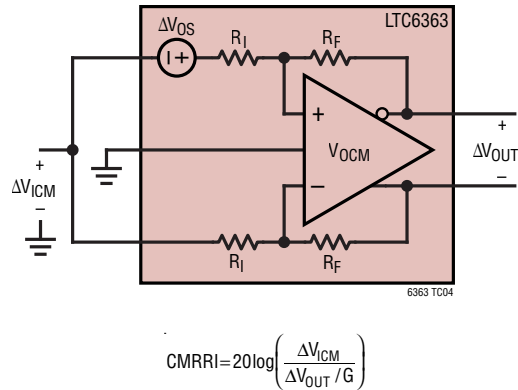

**Figure 9. Specified LTC6363-0.5, LTC6363-1 and LTC6363-2 CMRRI Is Referred to the Input Pins of the Part**

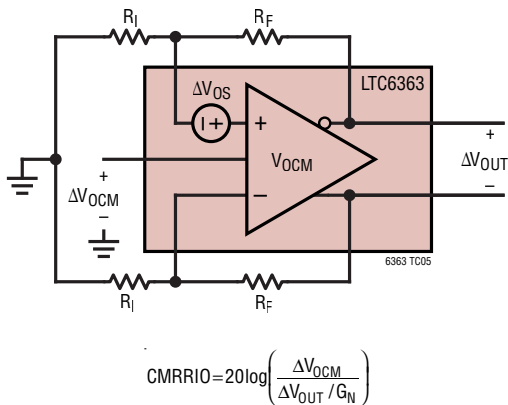

**Figure 10. Specified LTC6363 CMRRIO Is Referred to the Summing Junction**

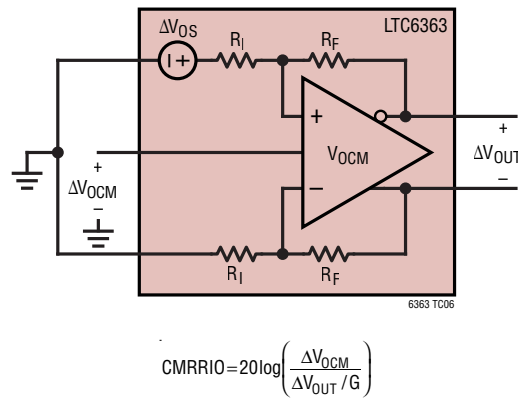

**Figure 11. Specified LTC6363-0.5, LTC6363-1 and LTC6363-2 CMRRIO Is Referred to the Input Pins of the Part**

# LTC6363 Family

**TEST CIRCUITS** Noise gain =  $G_N = 1 + \frac{R_F}{R_I}$ , closed loop gain =  $G = \frac{R_F}{R_I}$

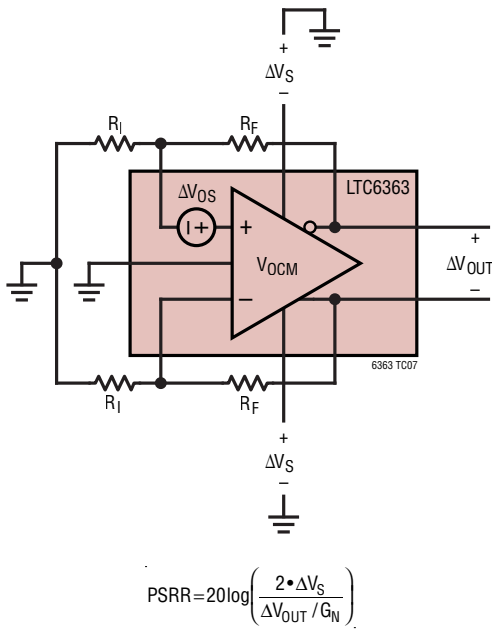

Figure 12. Specified LTC6363 PSRR Is Referred to the Summing Junction

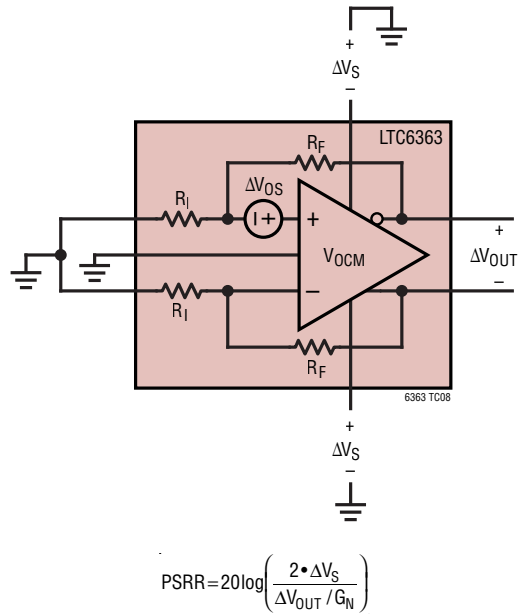

Figure 13. Specified LTC6363-0.5, LTC6363-1 and LTC6363-2 PSRR Is Referred to the Summing Junction

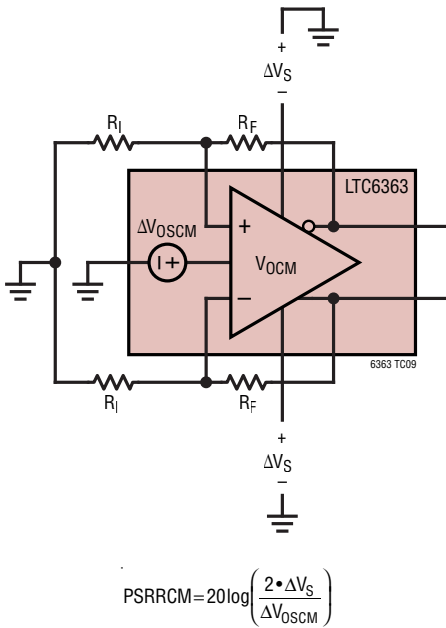

Figure 14. Specified LTC6363 PSRR<sub>CM</sub> Is Defined as the Ratio of the Change in Supply Voltage to the Change in Common Mode Offset Voltage

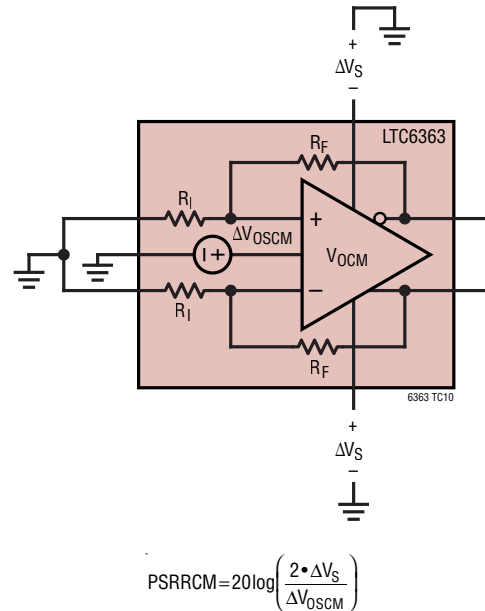

Figure 15. Specified LTC6363-0.5, LTC6363-1 and LTC6363-2 PSRR<sub>CM</sub> Is Defined as the Ratio of the Change in Supply Voltage to the Change in Common Mode Offset Voltage



**TEST CIRCUITS** Noise gain =  $G_N = 1 + \frac{R_F}{R_I}$ , closed loop gain =  $G = \frac{R_F}{R_I}$

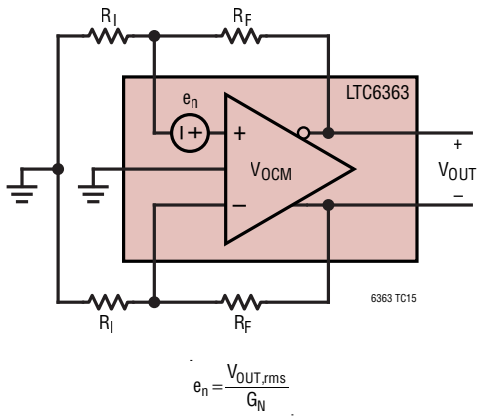

Figure 16. Specified LTC6363  $e_n$  Is Referred to the Summing Junction

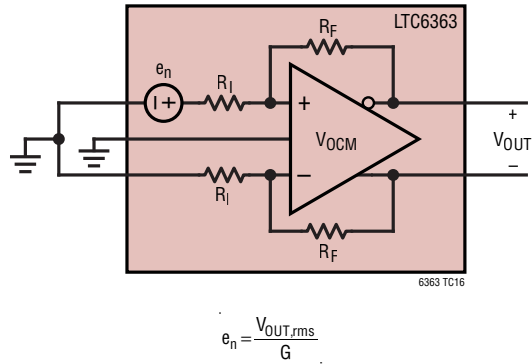
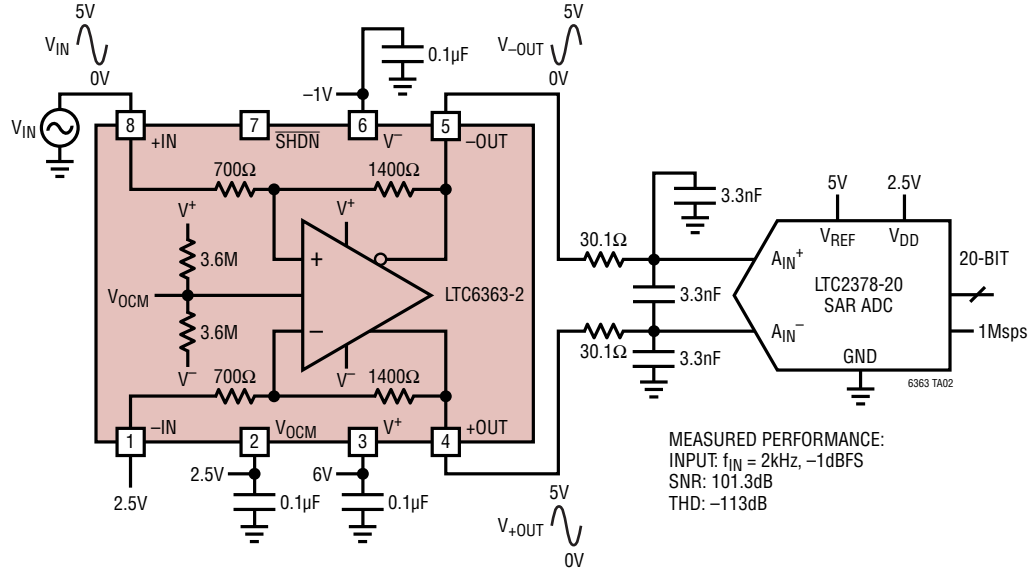

Figure 17. Specified LTC6363-0.5, LTC6363-1 and LTC6363-2  $e_n$  Is Referred to the Input Pins of the Part

## TYPICAL APPLICATIONS

Single-Ended-to-Differential Conversion of a  $5V_{p-p}$ , 2.5V Referenced Input with Gain of  $A_V = 2$  to Drive an ADC



Differentially Driving an ADC with  $\Delta V_{IN} = 10V_{p-p}$  and Gain of  $A_V = 1$

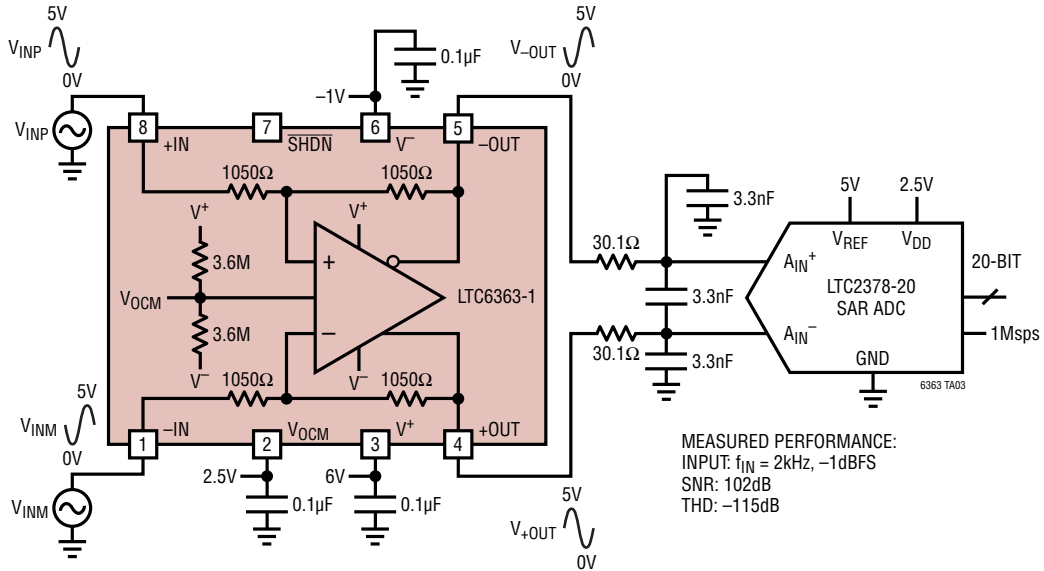

TYPICAL APPLICATIONS

Differentially Driving a Pipeline ADC with  $A_V = 1$

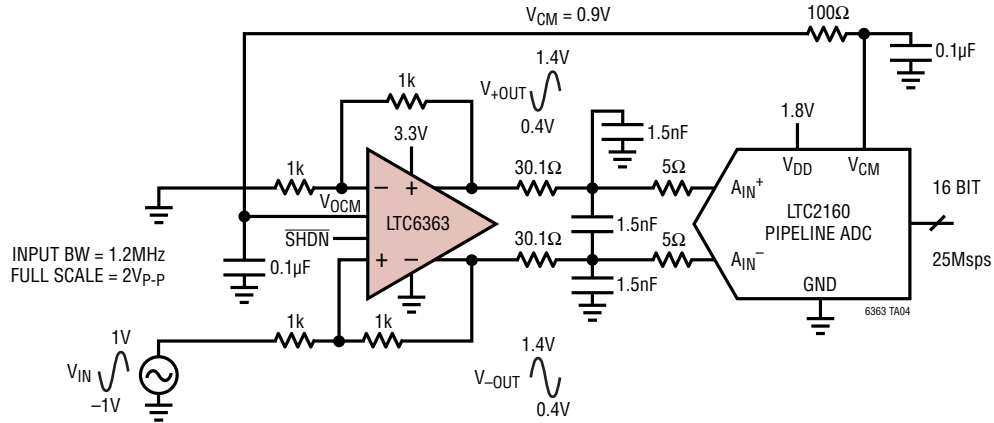

MEASURED PERFORMANCE FOR LTC6363 DRIVING LTC2160:  
 INPUT:  $f_{IN} = 2kHz, -1dBFS$   
 SNR: 77dB  
 HD2: -100.0dBc  
 HD3: -100.2dBc  
 THD: -96.5dB

Differential Line Driver Connected in Gain of  $A_V = 2$

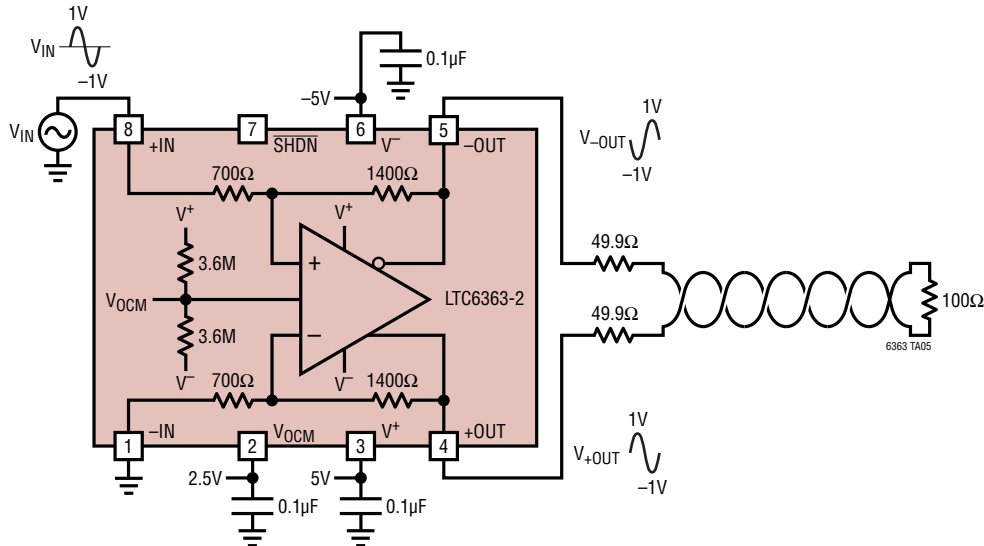

## TYPICAL APPLICATIONS

**LTC6363 Used as Lowpass Filter/Driver with 10V<sub>p-p</sub> Single-Ended Input, Driving a SAR ADC**

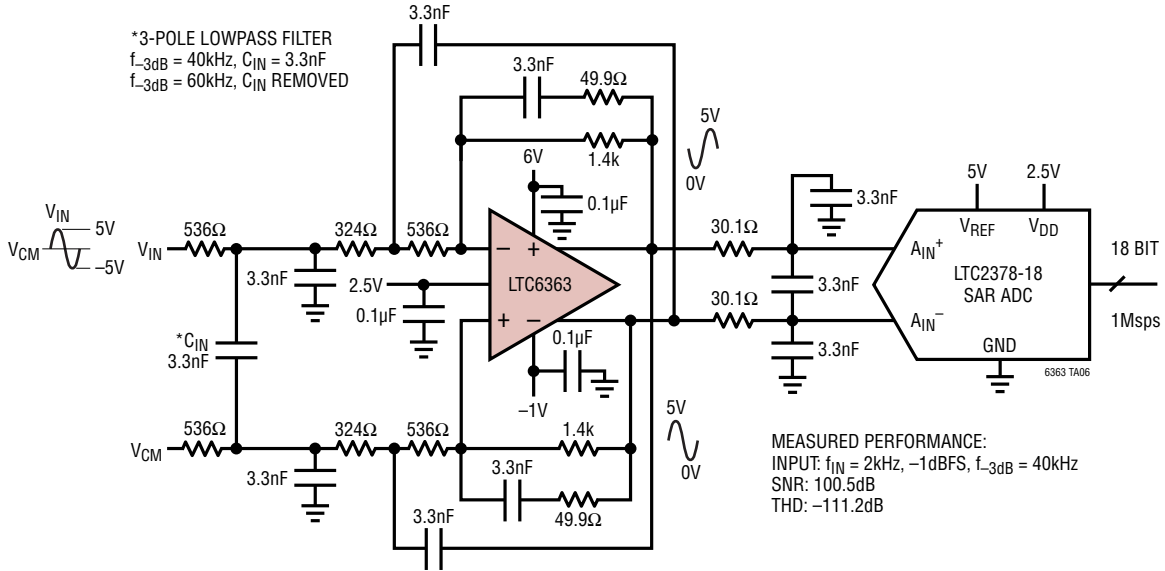

**Differential  $A_V = 1/9$  Configuration Using an LT<sup>®</sup>5400 Quad-Matched Resistor Network**

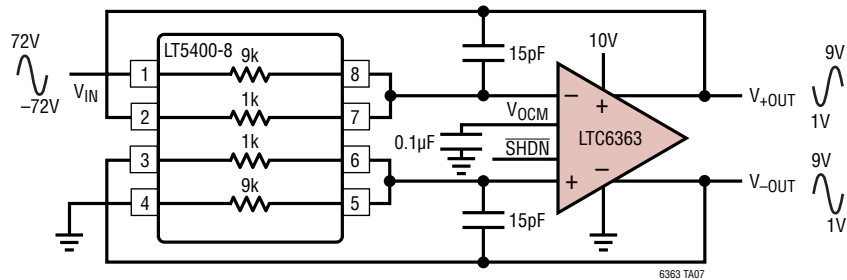

TYPICAL APPLICATIONS

LTC6363 Low Power, Low Noise, I and Q Signal Amplifier/Filter and LTC5599 Modulator

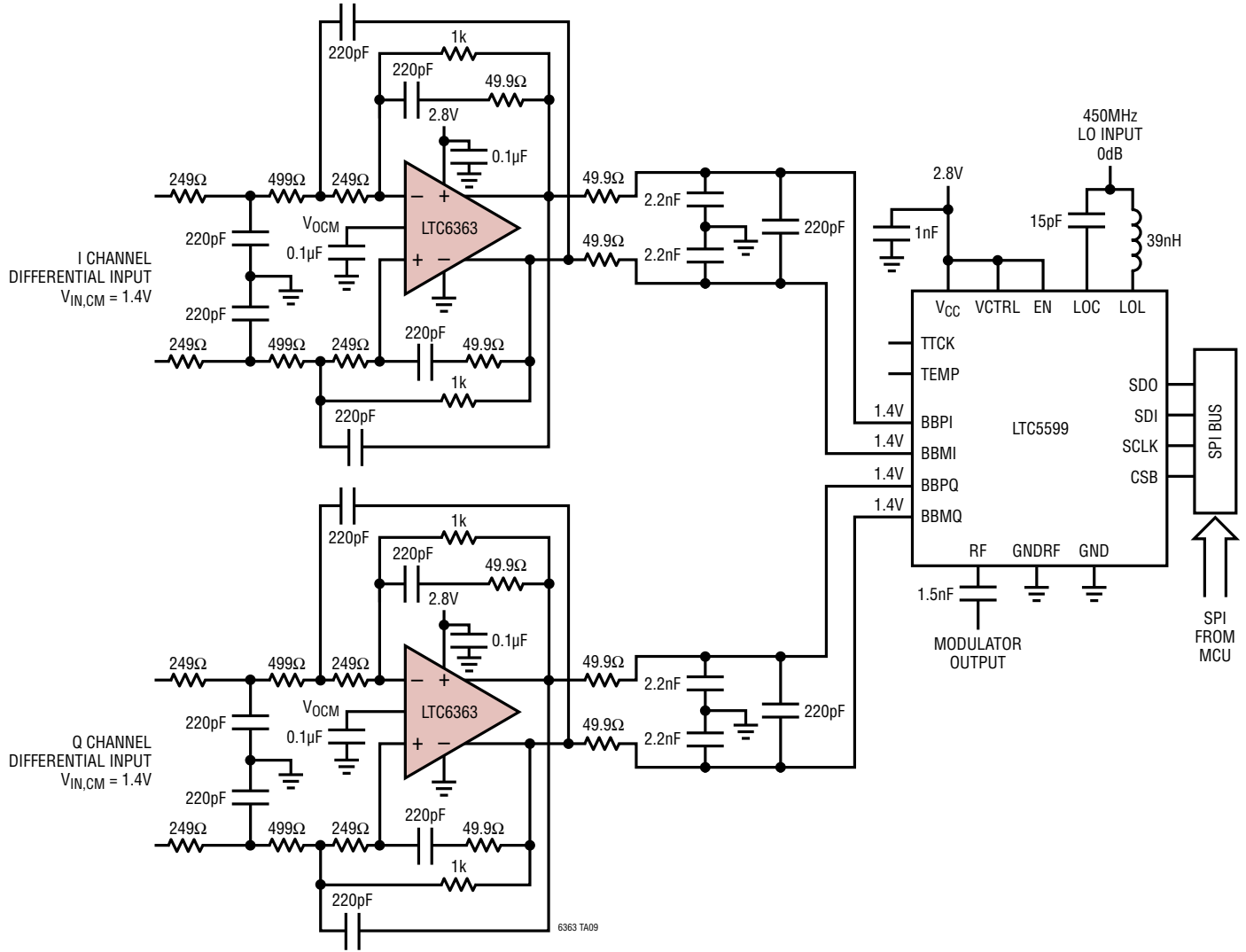

6363 TA09

## PACKAGE DESCRIPTION

### MS8 Package 8-Lead Plastic MSOP

(Reference LTC DWG # 05-08-1660 Rev G)

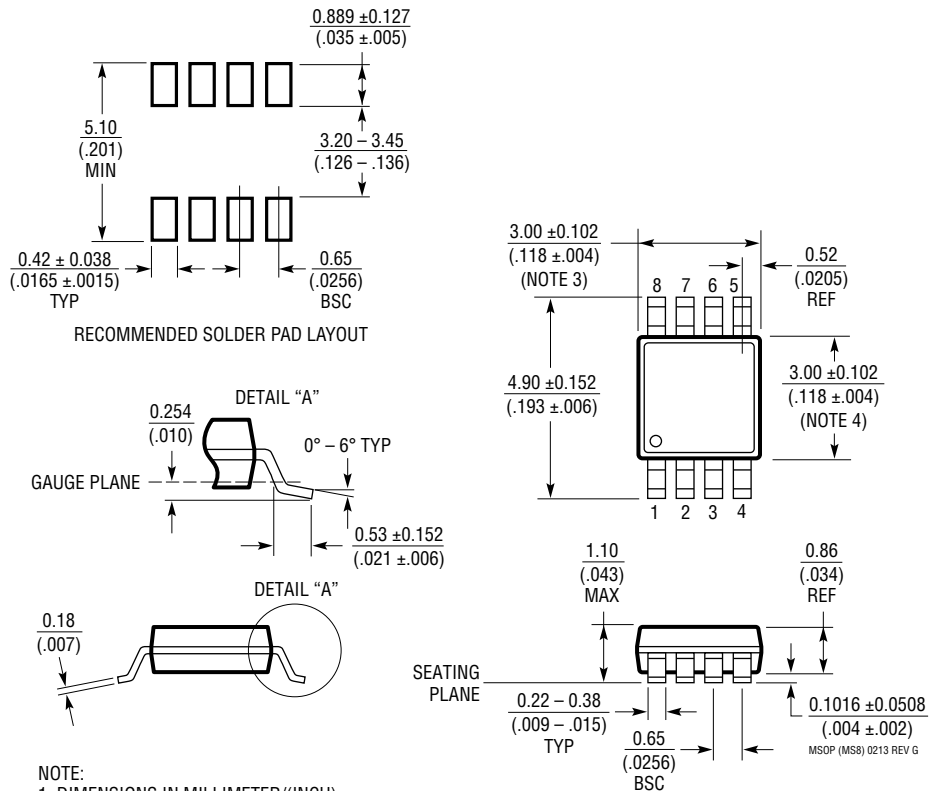

**NOTE:**

1. DIMENSIONS IN MILLIMETER/(INCH)
2. DRAWING NOT TO SCALE
3. DIMENSION DOES NOT INCLUDE MOLD FLASH, PROTRUSIONS OR GATE BURRS.  
MOLD FLASH, PROTRUSIONS OR GATE BURRS SHALL NOT EXCEED 0.152mm (.006") PER SIDE
4. DIMENSION DOES NOT INCLUDE INTERLEAD FLASH OR PROTRUSIONS.  
INTERLEAD FLASH OR PROTRUSIONS SHALL NOT EXCEED 0.152mm (.006") PER SIDE
5. LEAD COPLANARITY (BOTTOM OF LEADS AFTER FORMING) SHALL BE 0.102mm (.004") MAX

**PACKAGE DESCRIPTION**

**DCB Package**  
**8-Lead Plastic DFN (2mm × 3mm)**  
 (Reference LTC DWG # 05-08-1718 Rev A)

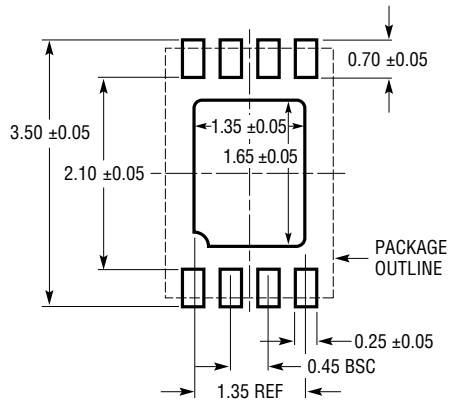

RECOMMENDED SOLDER PAD PITCH AND DIMENSIONS  
 APPLY SOLDER MASK TO AREAS THAT ARE NOT SOLDERED

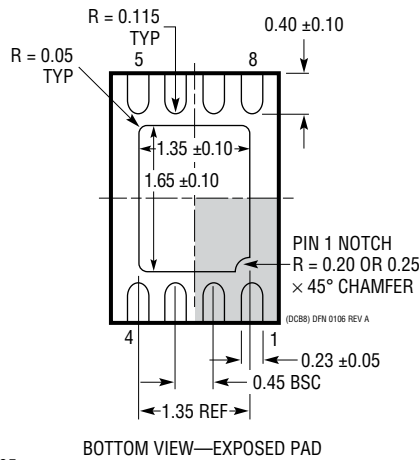
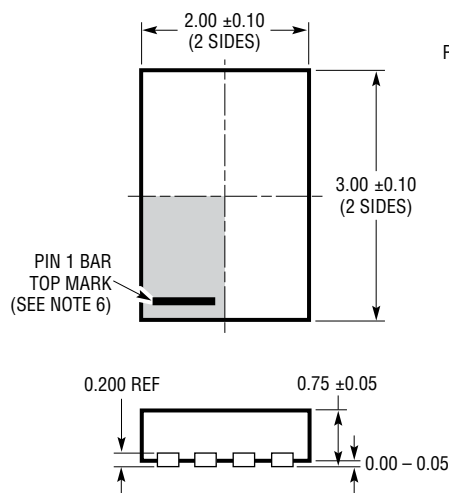

- NOTE:
1. DRAWING IS NOT A JEDEC PACKAGE OUTLINE
  2. DRAWING NOT TO SCALE
  3. ALL DIMENSIONS ARE IN MILLIMETERS
  4. DIMENSIONS OF EXPOSED PAD ON BOTTOM OF PACKAGE DO NOT INCLUDE MOLD FLASH. MOLD FLASH, IF PRESENT, SHALL NOT EXCEED 0.15mm ON ANY SIDE
  5. EXPOSED PAD SHALL BE SOLDER PLATED
  6. SHADED AREA IS ONLY A REFERENCE FOR PIN 1 LOCATION ON THE TOP AND BOTTOM OF PACKAGE





**REVISION HISTORY**

REV	DATE	DESCRIPTION	PAGE NUMBER
A	11/16	Common Mode Noise Voltage Density updated from $14\text{nv}/\sqrt{\text{Hz}}$ to $20\text{nv}/\sqrt{\text{Hz}}$ .	3
		Erroneous notes removed from Supply Current vs Supply Voltage graph.	6
		$\overline{\text{SHDN}}$ pin description updated.	10, 11
		Web links updated.	All
		Revision History added.	21
B	01/18	Family of parts added.	All
C	02/19	Added LFCSP Package	All

## TYPICAL APPLICATION

Single-Ended-to-Differential Conversion of a 20V<sub>p-p</sub> Ground-Referenced Input with Gain of  $A_V = 0.5$  to Drive an ADC

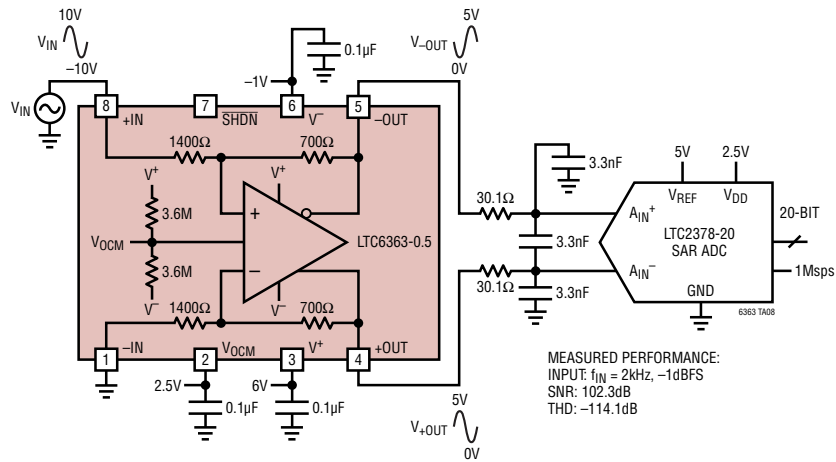

## RELATED PARTS

PART NUMBER	DESCRIPTION	COMMENTS
<b>Fully Differential Amplifiers</b>		
LTC6362	Precision, Low Power Rail-to-Rail Input/Output Differential Op Amp/SAR ADC Driver	1mA, $-116\text{dBc}$ Distortion at 1kHz, $8V_{p-p}$ Output
ADA4940-1/ADA4940-2	Ultralow Power, Low Distortion, Fully Differential ADC Drivers	1.25mA, $-96\text{dBc}$ Distortion at 1MHz, $2V_{p-p}$ Output
LTC1992/LTC1992-X	3MHz to 4MHz Fully Differential Input/Output Amplifiers	Internal Feedback Resistors Available ( $G = 1, 2, 5, 10$ )
LT1994	70MHz Low Noise, Low Distortion Fully Differential Input/Output Amplifier/Driver	13mA, $-94\text{dBc}$ Distortion at 1MHz, $2V_{p-p}$ Output
AD8475	Precision, Selectable Gain Funnel Amplifier	Internal Feedback Resistors ( $G = 0.4, 0.8$ )
AD8476	Low Power, Unity Gain ADC Driver/Amplifier	$330\mu\text{A}$ , $-126\text{dBc}$ Distortion at 10kHz, $1\text{ppm}/^\circ\text{C}$ Gain Drift
<b>Operational Amplifiers</b>		
LT6350	Low Noise, Single-Ended to Differential Converter/ADC Driver	$4.8\text{mA}$ , $-97\text{dBc}$ Distortion at 100kHz, $4V_{p-p}$ Output
LTC6246/LTC6247/LTC6248	Single/Dual/Quad 180MHz Rail-to-Rail Low Power Op Amps	1mA/Amplifier, $4.2\text{nV}/\sqrt{\text{Hz}}$
<b>Matched Resistor Networks</b>		
LT5400	Precision Quad Matched Resistor Networks	Ratios = 1:1, 1:4, 1:5, 1:9, 1:10
<b>ADCs</b>		
LTC2378-20	20-Bit, 1Msps, Low Power SAR ADC with 0.5ppm INL	2.5V Supply, Differential Input, 104dB SNR, $\pm 5V$ Input Range, DGC, Pin Compatible Family in MSOP-16 and $4\text{mm} \times 3\text{mm}$ DFN-16 Packages
LTC2379-18/LTC2378-18/LTC2377-18/LTC2376-18	18-Bit, 1.6Msps/1Msps/500ksps/250ksps Serial, Low Power ADC	2.5V Supply, Differential Input, 101.2dB SNR, $\pm 5V$ Input Range, DGC, Pin Compatible Family in MSOP-16 and $4\text{mm} \times 3\text{mm}$ DFN-16 Packages
AD4020	20-Bit, 1.8Msps, Low Power, Precision SAR ADC	1.8V Supply, Differential Input, 100.5dB SNR, $\pm 5V$ Input Range, $3\text{mm} \times 3\text{mm}$ LFCSP and MSOP-10 Packages
AD4003/AD4007/AD4011	18-Bit, 2Msps/1Msps/500ksps Precision, Differential SAR ADCs	1.8V Supply, Differential Input, 100.5dB SNR, $\pm 5V$ Input Range, $3\text{mm} \times 3\text{mm}$ LFCSP and MSOP-10 Packages
AD7691	18-Bit, 1.5LSB INL, 250ksps PulSAR Differential ADC	2.3V to 5V Supply, Differential Input, 101.5dB SNR, $\pm 5V$ Input Range, $3\text{mm} \times 3\text{mm}$ LFCSP and MSOP-10 Packages
AD7984	18-Bit, 1.33Msps PulSAR 10.5mW ADC in MSOP/LFCSP	2.5V Supply, Differential Input, 98.5dB SNR, $\pm 5V$ Input Range, $3\text{mm} \times 3\text{mm}$ LFCSP and MSOP-10 Packages

## X-ON Electronics

Largest Supplier of Electrical and Electronic Components

*Click to view similar products for [Data Conversion IC Development Tools](#) category:*

*Click to view products by [Analog Devices](#) manufacturer:*

Other Similar products are found below :

[EVAL-AD5063EBZ](#) [EVAL-AD5422LFEBZ](#) [EVAL-AD7265EDZ](#) [EVAL-AD7641EDZ](#) [EVAL-AD7674EDZ](#) [EVAL-AD7719EBZ](#) [EVAL-AD7767-1EDZ](#) [EVAL-AD7995EBZ](#) [AD9114-DPG2-EBZ](#) [AD9211-200EBZ](#) [AD9251-20EBZ](#) [AD9251-65EBZ](#) [AD9255-125EBZ](#) [AD9284-250EBZ](#) [AD9613-170EBZ](#) [AD9627-125EBZ](#) [AD9629-20EBZ](#) [AD9709-EBZ](#) [AD9716-DPG2-EBZ](#) [AD9737A-EBZ](#) [AD9787-DPG2-EBZ](#) [AD9993-EBZ](#) [DAC8555EVM](#) [ADS5482EVM](#) [ADS8372EVM](#) [EVAL-AD5061EBZ](#) [EVAL-AD5062EBZ](#) [EVAL-AD5443-DBRDZ](#) [EVAL-AD5570SDZ](#) [EVAL-AD7450ASDZ](#) [EVAL-AD7677EDZ](#) [EVAL-AD7992EBZ](#) [EVAL-AD7994EBZ](#) [AD9119-MIX-EBZ](#) [AD9148-M5375-EBZ](#) [AD9204-80EBZ](#) [AD9233-125EBZ](#) [AD9265-105EBZ](#) [AD9265-80EBZ](#) [AD9608-125EBZ](#) [AD9629-80EBZ](#) [AD9648-125EBZ](#) [AD9649-20EBZ](#) [AD9650-80EBZ](#) [AD9765-EBZ](#) [AD9767-EBZ](#) [AD9778A-DPG2-EBZ](#) [ADS8322EVM](#) [LM96080EB/NOPB](#) [EVAL-AD5445SDZ](#)