

LT1997 Configurable Precision Amplifier

DESCRIPTION

Demonstration Circuit 2551A is a Configurable Precision Amplifier featuring the [LT[®]1997](#).

The DC2551A-A supports the LT1997-3 version. The DC2551A-B supports the LT1997-2 version. The DC2551A-C supports the LT1997-1 version.

This demo board provides a rapid evaluation tool with jumpers providing the typical interconnection options that facilitate setting the pin-strapped internal gain configuration. The LT1997 is unusual in that it may be powered from a low voltage (down to 3.3V) while it accepts signals

well outside the supply range. This device also supports particularly high supply voltages, up to 50V. Connection points are provided to wire the amplifier in other configurations besides those possible with the jumpers alone.

The key performance characteristics of the LT1997-3 and DC2551A-A are shown in the Performance Summary below.

[Design files for this circuit board are available.](#)

All registered trademarks and trademarks are the property of their respective owners.

PERFORMANCE SUMMARY Specifications are at T_A = 25°C

SYMBOL	PARAMETER	CONDITIONS	MIN	TYP	MAX	UNITS
V _{+INA} , V _{-INA}	Input Range	Thermally Limited to Short-Term	-160		160	V
Other Inputs			-0.3		80	V
V ⁺ , V ⁻	Amplifier Supply Range (Total If Split Supplies)		3.3	5...30	50	V
V _{OUT}	Output Signal		V ⁻ +0.35		V ⁺ -0.7	V
I _{OUT}	Output Current Range		±10	±25		mA
I _S	Supply Current	I _{OUT} = 0		330	525	µA
BW	Small Signal -3dB Bandwidth		300		1100	kHz

OPERATING PRINCIPLES

The LT1997 family op amps include integrated precision resistors for providing many useful high accuracy functions with minimal external components. The default configuration of the demo circuit is a difference amplifier structure with gain set to minimum and the output referenced to mid-supply. Refer to the LT1997 data sheets for tabulations of various practical circuit configurations

that can be implemented, many of which are easily created by jumper relocation on the demo board. Large vias and some spare pads are also provided so that other more specialized configurations can be evaluated, such as AC-coupled gain blocks or summing amplifiers. The demo circuit also provides connector footprints for user-furnished BNC connectors if cable connectivity is desired.

QUICK START PROCEDURE

Demonstration circuit 2551A is easy to set up to evaluate the performance of the LT1997. Refer to Figure 1 for a suitable equipment setup and follow the procedure below:

1. Place jumpers in the following positions:

JP1, JP2 to the **ENable** position

JP6 to the **-IN** position

JP7 to the **+IN** position

JP11-JP13 to the **SPLIT** position as shown (**JP11** and **JP12** should generally be positioned as a set).

JP3-JP5, JP8-JP10 should be removed or connected to just one of their posts.

2. With power off, connect the power supply positive to **+V**, the supply negative to **-V**, and the common to **GND**. The supplies should be preset in the range of $\pm 1.7V$ to $\pm 25V$.

3. Connect a voltmeter or oscilloscope probe to the **OUT** terminal, with the common connection or ground clip tied to **GND**.

4. Connect a signal source to the **+IN** and **-IN**.

NOTE: Generators will typically be referenced to earth ground. An AC 'cheater' plug may be needed if a deliberate offset is to be introduced with another power supply.

5. Turn on the power supplies.

6. Check for an output voltage that is a replica of the input signal processed with the appropriate gain.

QUICK START PROCEDURE

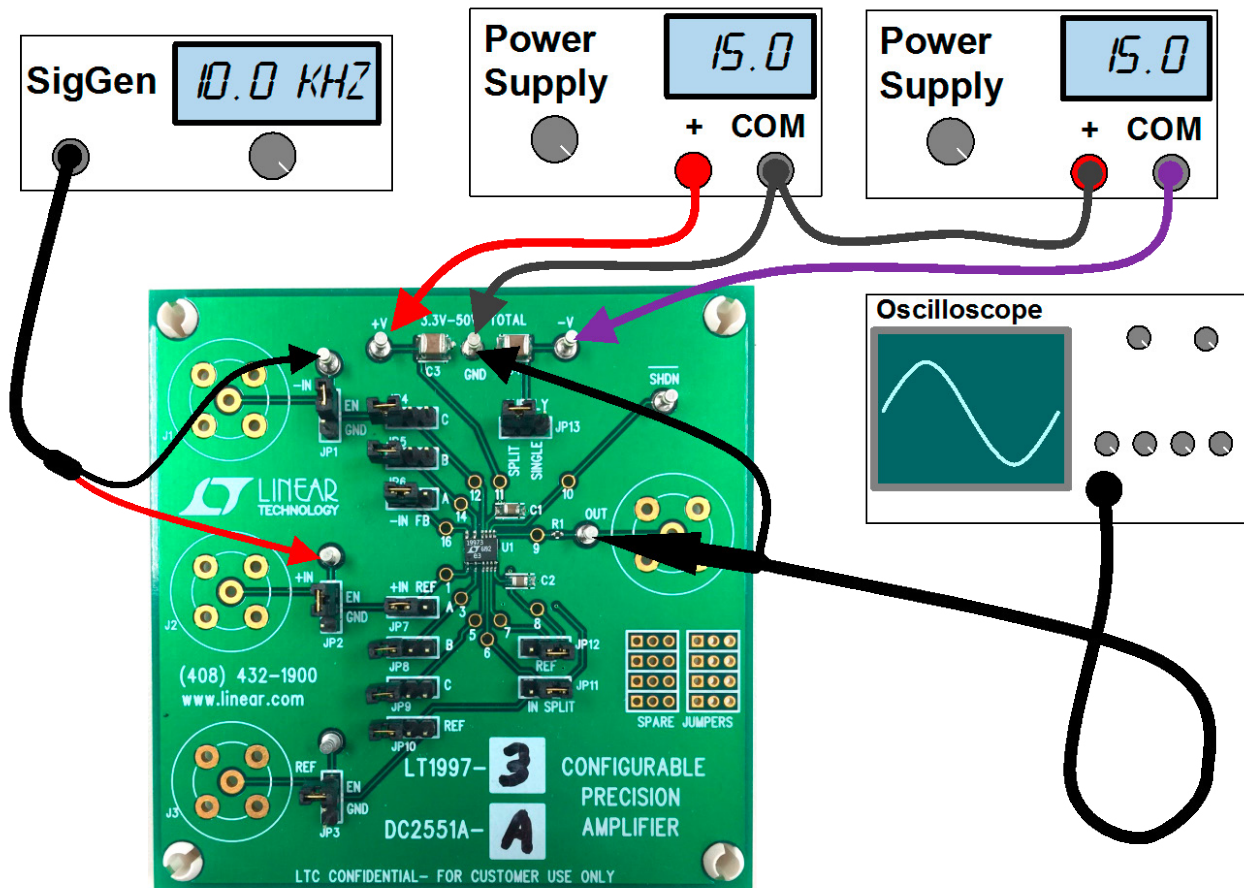

Figure 1. Proper Evaluation Equipment Setup



ESD Caution

ESD (electrostatic discharge) sensitive device. Charged devices and circuit boards can discharge without detection. Although this product features patented or proprietary protection circuitry, damage may occur on devices subjected to high energy ESD. Therefore, proper ESD precautions should be taken to avoid performance degradation or loss of functionality.

Legal Terms and Conditions

By using the evaluation board discussed herein (together with any tools, components documentation or support materials, the "Evaluation Board"), you are agreeing to be bound by the terms and conditions set forth below ("Agreement") unless you have purchased the Evaluation Board, in which case the Analog Devices Standard Terms and Conditions of Sale shall govern. Do not use the Evaluation Board until you have read and agreed to the Agreement. Your use of the Evaluation Board shall signify your acceptance of the Agreement. This Agreement is made by and between you ("Customer") and Analog Devices, Inc. ("ADI"), with its principal place of business at One Technology Way, Norwood, MA 02062, USA. Subject to the terms and conditions of the Agreement, ADI hereby grants to Customer a free, limited, personal, temporary, non-exclusive, non-sublicensable, non-transferable license to use the Evaluation Board FOR EVALUATION PURPOSES ONLY. Customer understands and agrees that the Evaluation Board is provided for the sole and exclusive purpose referenced above, and agrees not to use the Evaluation Board for any other purpose. Furthermore, the license granted is expressly made subject to the following additional limitations: Customer shall not (i) rent, lease, display, sell, transfer, assign, sublicense, or distribute the Evaluation Board; and (ii) permit any Third Party to access the Evaluation Board. As used herein, the term "Third Party" includes any entity other than ADI, Customer, their employees, affiliates and in-house consultants. The Evaluation Board is NOT sold to Customer; all rights not expressly granted herein, including ownership of the Evaluation Board, are reserved by ADI. CONFIDENTIALITY. This Agreement and the Evaluation Board shall all be considered the confidential and proprietary information of ADI. Customer may not disclose or transfer any portion of the Evaluation Board to any other party for any reason. Upon discontinuation of use of the Evaluation Board or termination of this Agreement, Customer agrees to promptly return the Evaluation Board to ADI. ADDITIONAL RESTRICTIONS. Customer may not disassemble, decompile or reverse engineer chips on the Evaluation Board. Customer shall inform ADI of any occurred damages or any modifications or alterations it makes to the Evaluation Board, including but not limited to soldering or any other activity that affects the material content of the Evaluation Board. Modifications to the Evaluation Board must comply with applicable law, including but not limited to the RoHS Directive. TERMINATION. ADI may terminate this Agreement at any time upon giving written notice to Customer. Customer agrees to return to ADI the Evaluation Board at that time. LIMITATION OF LIABILITY. THE EVALUATION BOARD PROVIDED HEREUNDER IS PROVIDED "AS IS" AND ADI MAKES NO WARRANTIES OR REPRESENTATIONS OF ANY KIND WITH RESPECT TO IT. ADI SPECIFICALLY DISCLAIMS ANY REPRESENTATIONS, ENDORSEMENTS, GUARANTEES, OR WARRANTIES, EXPRESS OR IMPLIED, RELATED TO THE EVALUATION BOARD INCLUDING, BUT NOT LIMITED TO, THE IMPLIED WARRANTY OF MERCHANTABILITY, TITLE, FITNESS FOR A PARTICULAR PURPOSE OR NON-INFRINGEMENT OF INTELLECTUAL PROPERTY RIGHTS. IN NO EVENT WILL ADI AND ITS LICENSORS BE LIABLE FOR ANY INCIDENTAL, SPECIAL, INDIRECT, OR CONSEQUENTIAL DAMAGES RESULTING FROM CUSTOMER'S POSSESSION OR USE OF THE EVALUATION BOARD, INCLUDING BUT NOT LIMITED TO LOST PROFITS, DELAY COSTS, LABOR COSTS OR LOSS OF GOODWILL. ADI'S TOTAL LIABILITY FROM ANY AND ALL CAUSES SHALL BE LIMITED TO THE AMOUNT OF ONE HUNDRED US DOLLARS (\$100.00). EXPORT. Customer agrees that it will not directly or indirectly export the Evaluation Board to another country, and that it will comply with all applicable United States federal laws and regulations relating to exports. GOVERNING LAW. This Agreement shall be governed by and construed in accordance with the substantive laws of the Commonwealth of Massachusetts (excluding conflict of law rules). Any legal action regarding this Agreement will be heard in the state or federal courts having jurisdiction in Suffolk County, Massachusetts, and Customer hereby submits to the personal jurisdiction and venue of such courts. The United Nations Convention on Contracts for the International Sale of Goods shall not apply to this Agreement and is expressly disclaimed.

X-ON Electronics

Largest Supplier of Electrical and Electronic Components

Click to view similar products for [Amplifier IC Development Tools](#) category:

Click to view products by [Analog Devices](#) manufacturer:

Other Similar products are found below :

[EVAL-ADCMP566BCPZ](#) [EVAL-ADCMP606BKSZ](#) [AD8013AR-14-EBZ](#) [AD8033AKS-EBZ](#) [AD8044AR-EBZ](#) [AD8225-EVALZ](#)
[ADA4859-3ACP-EBZ](#) [ADA4862-3YR-EBZ](#) [DEM-OPA-SO-2B](#) [AD744JR-EBZ](#) [AD8023AR-EBZ](#) [AD8030ARJ-EBZ](#) [AD8040ARU-EBZ](#)
[AD8073JR-EBZ](#) [AD813AR-14-EBZ](#) [AD848JR-EBZ](#) [ADA4858-3ACP-EBZ](#) [ADA4922-1ACP-EBZ](#) [551600075-001/NOPB](#) [DEM-OPA-SO-](#)
[2E](#) [THS7374EVM](#) [EVAL-ADCMP553BRMZ](#) [EVAL-ADCMP608BKSZ](#) [MIOP 42109](#) [EVAL-ADCMP609BRMZ](#) [MAX9928EVKIT+](#)
[MAX9636EVKIT+](#) [MAX9611EVKIT](#) [MAX9937EVKIT+](#) [MAX9934TEVKIT+](#) [MAX44290EVKIT#](#) [MAX2644EVKIT](#) [MAX4073EVKIT+](#)
[DEM-OPA-SO-2C](#) [MAX2643EVKIT](#) [ISL28158EVAL1Z](#) [MAX40003EVKIT#](#) [MAX2473EVKIT](#) [MAX2472EVKIT](#) [MAX4223EVKIT](#)
[MAX9700BEVKIT](#) [MADL-011014-001SMB](#) [DC1685A](#) [DEM-OPA-SO-2D](#) [MAX2670EVKIT#](#) [DEM-OPA-SO-1E](#) [AD8137YCP-EBZ](#)
[EVAL-ADA4523-1ARMZ](#) [MAX44242EVKIT#](#) [EVAL-LT5401_32FDAZ](#)