

LTC1707 Monolithic Synchronous Step-Down Regulator

DESCRIPTION

Demonstration circuit DC257 is a constant-frequency step-down converter using an LTC[®]1707 monolithic synchronous regulator. It provides low input voltage, high conversion efficiency for cell phones and other portable electronics operating from one or two Li-Ion cells or three to six NiCd cells. Constant 350kHz operation and up to 600mA output capability in an SO-8 package provide a low noise, space-efficient solution for wireless applications.

The circuit highlights the capability of the LTC1707. Designed to work at low voltages, the input voltage (V_{IN}) can range from 2.85V to 8.5V. At $V_{IN} < 2.7V$, the LTC1707 shuts down and draws just a few microamperes, making

it ideal for single lithium-ion battery applications. DC257's output voltage is programmable from 1.5V to 3.3V via a jumper.

At low output currents, the LTC1707 automatically switches to Burst Mode[™] operation to reduce switching losses and maintain high operating efficiencies. In switching-noise sensitive applications, Burst Mode operation can be inhibited by grounding the SYNC/MODE pin or synchronizing it with an external clock. **Gerber files for this circuit board are available. Call the LTC factory.**

LTC, LTC and LT are registered trademarks of Linear Technology Corporation. Burst Mode is a trademark of Linear Technology Corporation.

PERFORMANCE SUMMARY

SYMBOL	PARAMETER	CONDITIONS	JUMPER POSITION	VALUE
V_{IN}	Input Voltage Range			2.85V to 8.5V
V_{OUT}	Output Voltage	See Figure 2	JP1 = "1.5V" JP1 = "1.8V" JP1 = "2.5V" JP1 = "2.9V" JP1 = "3.3V" JP1 = "OPEN"	1.51V ± 0.036V 1.82V ± 0.043V 2.52V ± 0.06V 2.94V ± 0.07V 3.33V ± 0.079V Note 1
I_Q	Pulse Skipping Mode Supply Current Burst Mode Enabled Supply Current Shutdown Current	$V_{IN} = 5V$, SYNC/MODE = 0V, RUN/SS = 2V, $I_{OUT} = 0mA$ $V_{IN} = 5V$, SYNC/MODE = 2V, RUN/SS = 2V, $I_{OUT} = 0mA$ $V_{IN} = 5V$, RUN/SS = 0V, $I_{OUT} = 0mA$	JP1 = "3.3V" JP1 = "3.3V" JP1 = "3.3V"	300µA 200µA 15µA

TYPICAL PERFORMANCE CHARACTERISTICS AND BOARD PHOTO

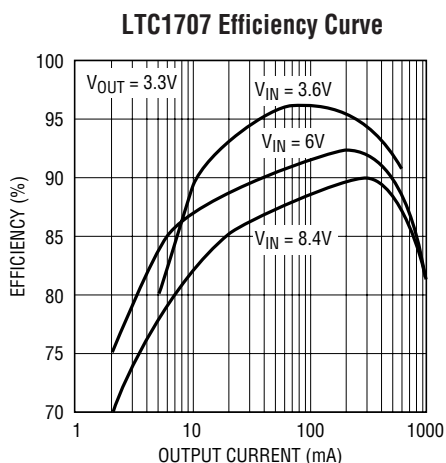

Demo Board



DEMO MANUAL DC257

NO-DESIGN SWITCHER

PERFORMANCE SUMMARY

SYMBOL	PARAMETER	CONDITIONS	JUMPER POSITION	VALUE
I_{OUT}	Minimum Output Current	$V_{IN} = 5V, V_{OUT} = 2.5V$ $V_{IN} = 5V, V_{OUT} = 3.3V$ $V_{IN} = 3V, V_{OUT} = 2.5V$		600mA 500mA 300mA
f_{OSC}	Operating Frequency	Unsynchronized Synchronized	All All	350kHz 385kHz to 550kHz
V_{RIPPLE}	Typical Output Ripple	$I_{OUT} = 500mA, V_{IN} = 5V, V_{OUT} = 3.3V$		30mV _{p-p}
V_{OUT}	Typical Load Regulation	$0mA < I_{OUT} < 0.5A, V_{IN} = 5V, V_{OUT} = 3.3V$		0.5%
V_{SYNC}	Synchronize Threshold Voltage		All	1.2V
$V_{RUN/SS}$	Minimum Shutdown Threshold Voltage		All	0.4V
V_{REF}	Reference Output Voltage	$I_{REF} = 0$	All	1.19V
I_{REF}	Maximum V_{REF} Output Current		All	100 μ A

Note 1: Programmable via optional R6. $V_{OUT} = 0.8V(1 + 210k/R6)$

PACKAGE AND SCHEMATIC DIAGRAMS

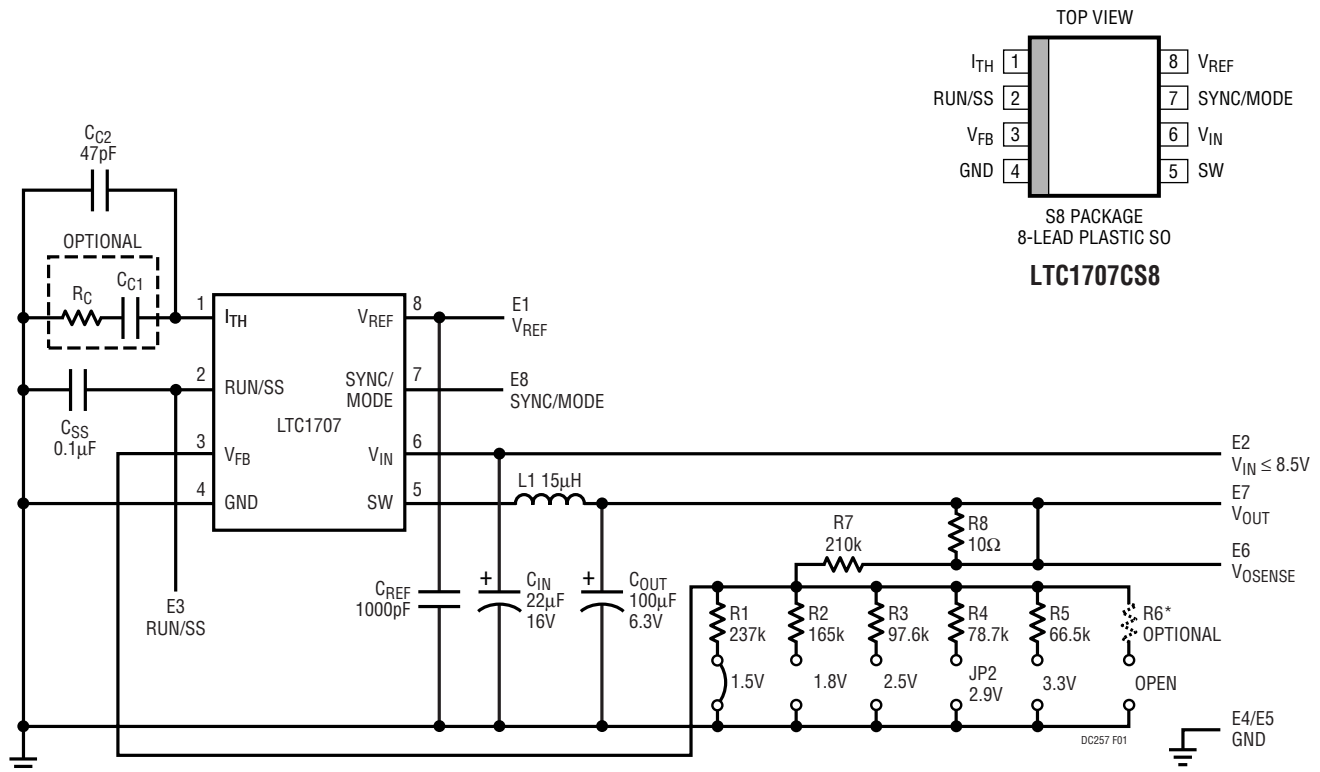

*SPACE IS PROVIDED FOR AN OPTIONAL RESISTOR TO PROGRAM A CUSTOM OUTPUT VOLTAGE. THE OUTPUT VOLTAGE MUST NOT EXCEED 3.3V

Figure 1. LTC1707 Constant Frequency, High Efficiency Converter

PARTS LIST

REFERENCE DESIGNATOR	QUANTITY	PART NUMBER	DESCRIPTION	VENDOR	TELEPHONE
C _{IN}	1	TPSC226M016R0375	22 μ F 16V TPS Tantalum Capacitor	AVX	(207) 282-5111
C _{OUT}	1	TPSC107M006R0150	100 μ F 6V TPS Tantalum Capacitor	AVX	(207) 282-5111
C _{SS}	1	0603YC104KAT	0.1 μ F 16V X7R Chip Capacitor	AVX	(843) 946-0362
C _{REF}	1	06035A102JAT	1000pF 50V NPO Chip Capacitor	AVX	(843) 946-0362
C _{C1}			Optional		
C _{C2}	1	06035A470JAT	47pF 50V NPO Chip Capacitor	AVX	(843) 946-0362
E1 to E8	8	2501-2	Turret, Testpoint	Mill-Max	(516) 922-6000
JP1	1	22025-12-G1	0.079" Double Row Header	COMM CON	(626) 301-4200
JP1	1	CCIJ2MM-138G	0.079" Center Shunt	COMM CON	(626) 301-4200
L1	1	CD54-150MC	15 μ H 20% Inductor	Sumida	(847) 956-0667
R1	1	CR16-2373FM	237k 1% 1/16W Chip Resistor	TAD	(800) 508-1521
R2	1	CR16-1653FM	165k 1% 1/16W Chip Resistor	TAD	(800) 508-1521
R3	1	CR16-9762FM	97.6k 1% 1/16W Chip Resistor	TAD	(800) 508-1521
R4	1	CR16-7872FM	78.7k 1% 1/16W Chip Resistor	TAD	(800) 508-1521
R5	1	CR16-6652FM	66.5k 1% 1/16W Chip Resistor	TAD	(800) 508-1521
R7	1	CR16-2103FM	210k 1% 1/16W Chip Resistor	TAD	(800) 508-1521
R8	1	CR16-100JM	10 Ω 5% 1/16W Chip Resistor	TAD	(800) 508-1521
R6			Optional		
R _C			Optional		
U1	1	LTC1707CS8	Monolithic Synchronous Step-Down Regulator	LTC	(408) 432-1900

QUICK START GUIDE

This demonstration board is easily set up to evaluate the performance of the LTC1707 IC. Please follow the procedure outlined below for proper operation.

- Refer to Figure 5 for proper connection of monitoring equipment to ensure correct measurement.
- Connect the input power supply to the V_{IN} and GND terminals on the left-hand side of the board. Do not increase V_{IN} over 10V or the part will be damaged.
- Connect the load between the V_{OUT} and GND terminals on the right side of the board.
- The RUN/SS pin can be left unconnected. To shut down the LTC1707, tie this pin to GND.
- Set the desired output voltage with jumper JP1, as shown in Figure 2 and Table 1.

Table 1. Output Voltage Selection

JP1 POSITION	OUTPUT VOLTAGE
“1.5V”	1.51V
“1.8V”	1.82V
“2.5V”	2.52V
“2.9V”	2.94V
“3.3V”	3.33V
“OPEN”	



**Figure 2. Output Voltage Selection (JP1)
(3.3V Position Shown)**

OPERATION

The circuit in Figure 1 highlights the capabilities of the LTC1707. The application circuit is set up for a variety of output voltages. Output voltages from 1.5V to 3.3V or user programmable voltages can be obtained by selecting the appropriate jumper position.

The LTC1707 is a monolithic synchronous step-down switching regulator using a fixed-frequency architecture. Burst Mode operation provides high efficiency at low load currents. Operating efficiencies typically exceed 90% over two decades of load current range. 100% duty cycle provides low dropout operation, which extends operating time in battery-operated systems.

Do not use small spring-clip leads when testing this circuit. Soldered wire connections are required to properly verify the performance of the PC board.

This demonstration board is intended for the evaluation of the LTC1707 switching regulator IC and was not designed for any other purpose.

The operating frequency of this demo circuit is 350kHz, the frequency of the LTC1707’s internal oscillator. For higher frequencies, SYNC/MODE (E8) can be synchronized with an external clock. Burst Mode operation is automatically disabled when the SYNC/MODE pin is externally driven. Grounding SYNC/MODE also disables Burst Mode operation, potentially reducing noise and RF interference.

Soft-start is provided by an external capacitor, C_{SS} , which can be used to properly sequence supplies. The maximum operating current level is 0.6A.

This demo board is optimized for 3.3V outputs and 5V input. Output voltages from 1.5V to 3.3V are available by selecting the appropriate position of JP1. For other output voltages, select the OPEN position and add an appropriate resistor value in the space provided. The output voltage must never exceed 3.3V because the output capacitor may be damaged. The input supply can range from 2.85V to 8.5V.

OPERATION

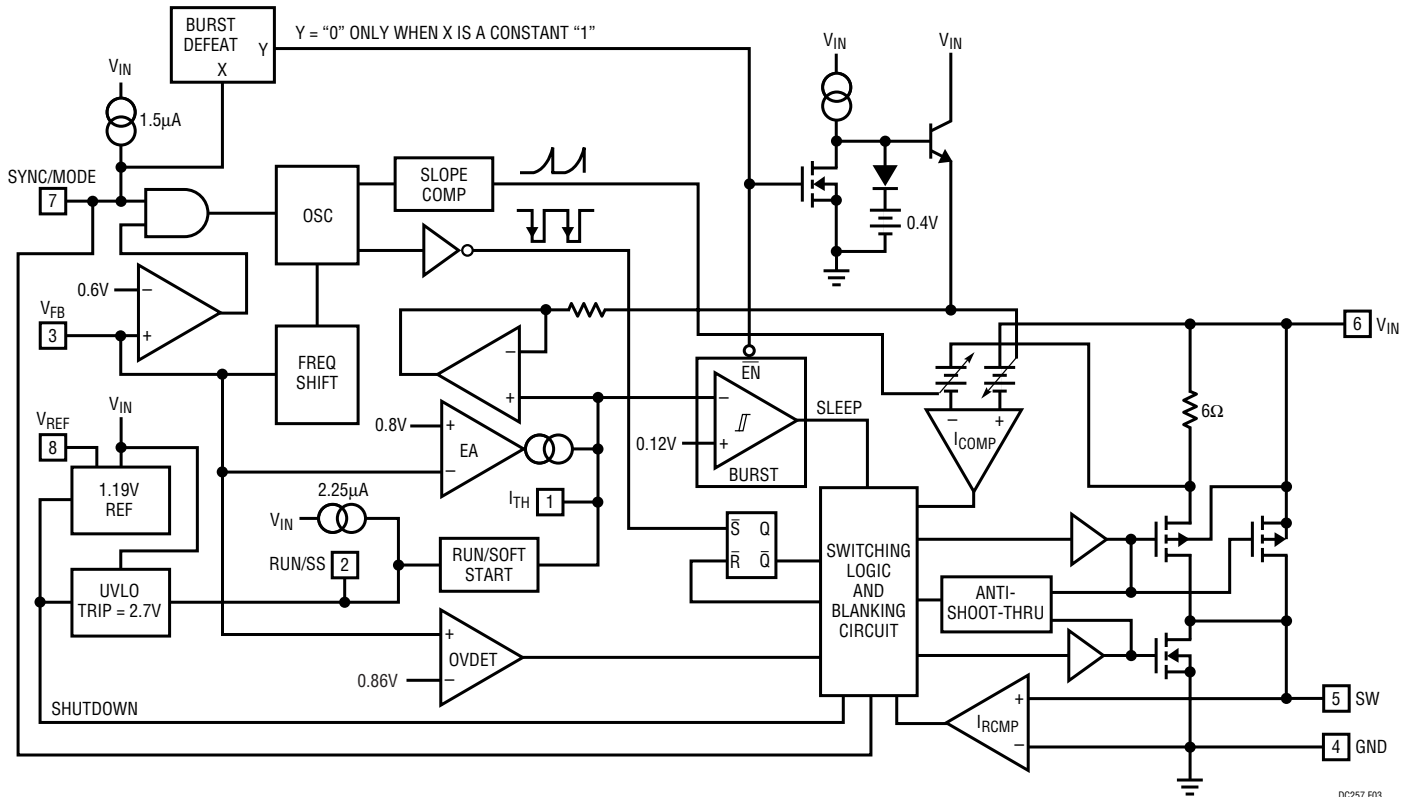

Figure 3. Functional Block Diagram

Main Control Loop (Refer to Functional Diagram)

The LTC1707 uses a constant-frequency, current mode step-down architecture. Both the main and synchronous switches, consisting of top P-channel and bottom N-channel power MOSFETs, are internal. During normal operation, the internal top power MOSFET is turned on during each cycle when the oscillator sets the RS latch, and turned off when the current comparator, I_{COMP} , resets the RS latch. The peak inductor current at which I_{COMP} resets the RS latch is controlled by the voltage on the I_{TH} pin, which is the output of error amplifier EA. The V_{FB} pin allows EA to receive an output feedback voltage from an external resistive divider. When the load current increases,

it causes a slight decrease in the feedback voltage relative to the 0.8V reference, which, in turn, causes the I_{TH} voltage to increase until the average inductor current matches the new load current. While the top MOSFET is off, the bottom MOSFET is turned on until either the inductor current starts to reverse, as indicated by the current reversal comparator I_{RCMP} , or the next cycle begins.

The main control loop is shut down by pulling the RUN/SS pin low. Releasing RUN/SS allows an internal $2.25\mu A$ current source to charge soft-start capacitor C_{SS} . When C_{SS} reaches 0.7V, the main control loop is enabled with the I_{TH} voltage clamped at approximately 5% of its

OPERATION

maximum value. As C_{SS} continues to charge, I_{TH} is gradually released, allowing normal operation to resume.

Comparator OVDET guards against transient overshoots $> 7.5\%$ by turning the main switch off and keeping it off until the fault is removed.

SYNC/MODE Pin Function (Frequency Synchronization and Burst Mode Disable)

The LTC1707 can be synchronized with an external TTL/CMOS-compatible clock signal driving the SYNC/MODE pin (E8). The frequency range of this signal must be from 385kHz to 550kHz. DO NOT attempt to synchronize the LTC1707 below 385kHz as this may cause abnormal operation and an undesired frequency spectrum. The top MOSFET turn-on follows the rising edge of the external source.

When the LTC1707 is clocked by an external source, Burst Mode operation is disabled; the LTC1707 then operates in PWM pulse-skipping mode. In this mode, when the output load is very low, current comparator I_{COMP} remains tripped for more than one cycle and forces the main switch to stay off for the same number of cycles. Increasing the output load slightly allows constant-frequency PWM operation to resume.

Frequency synchronization is inhibited when the feedback voltage, V_{FB} , is below 0.6V. This prevents the external clock from interfering with the frequency foldback for short-circuit protection.

The LTC1707 is capable of Burst Mode operation, in which the internal power MOSFETs operate intermittently based on load demand. To enable Burst Mode operation, simply allow the SYNC/MODE pin to float or connect it to a logic high. To disable Burst Mode operation and enable PWM pulse-skipping mode, connect the SYNC/MODE pin to GND.

When the converter uses Burst Mode operation, the peak current of the inductor is set to approximately 200mA, even though the voltage at the I_{TH} pin indicates a lower value. The voltage at the I_{TH} pin drops when the inductor's average current is greater than the load requirement. As the I_{TH} voltage drops below 0.12V, the BURST comparator trips, causing the internal sleep line to go high and turn off both power MOSFETs.

In sleep mode, both power MOSFETs are held off and the internal circuitry is partially turned off, reducing the quiescent current to 200 μ A. The load current is now supplied from the output capacitor. When the output voltage drops, causing I_{TH} to rise above 0.22V, the top MOSFET is again turned on and this process repeats.

SHORT-CIRCUIT PROTECTION

When the output is shorted to ground, the frequency of the oscillator is reduced to about 35kHz, 1/10 of the nominal frequency. This frequency foldback ensures that the inductor current has more time to decay, thereby preventing runaway. The oscillator's frequency will gradually increase to 350kHz (or the synchronized frequency) when V_{FB} rises above 0.3V.

DROPOUT OPERATION

When the input supply voltage decreases toward the output voltage, the duty cycle increases toward the maximum on-time. Further reduction of the supply voltage forces the main switch to remain on for more than one cycle until it reaches 100% duty cycle. The output voltage will then be determined by the input voltage minus the voltage drop across the P-channel MOSFET and the inductor. In Burst Mode operation or pulse skipping mode operation with the outputs lightly loaded, the LTC1707 passes through continuous mode as it enters dropout.

OPERATION

UNDERVOLTAGE LOCKOUT

A precision undervoltage lockout shuts down the LTC1707 when V_{IN} drops below 2.7V, making it ideal for single lithium-ion battery applications. In shutdown, the LTC1707 draws only several microamperes, which is low enough to prevent deep discharge and possible damage to a lithium-ion battery nearing its end of charge. A 150mV hysteresis ensures reliable operation with noisy supplies.

LOW SUPPLY OPERATION

The LTC1707 is designed to operate from supply voltages as low as 2.85V. At this voltage, the converter is most likely to be running at high duty cycles or in dropout, where the main switch is on continuously. Hence, the I^2R loss is due mainly to the $R_{DS(ON)}$ of the P-channel MOSFET. See the LTC1707 data sheet for additional information.

SLOPE COMPENSATION AND PEAK INDUCTOR CURRENT

Slope compensation provides stability by preventing sub-harmonic oscillations. It works by internally adding a ramp to the inductor current signal at duty cycles in excess of 40%. As a result, the maximum inductor peak current is

lower for $V_{OUT}/V_{IN} > 0.4$ than when $V_{OUT}/V_{IN} < 0.4$. See the maximum inductor peak current vs duty cycle graph in Figure 4.

The graph labeled “With External Clock” shows the worst-case peak current reduction obtained when the oscillator is synchronized at its minimum frequency, that is, to a clock just above the oscillator’s free-running frequency.

HOW TO MEASURE VOLTAGE REGULATION

When trying to measure voltage regulation, remember that all measurements must be taken at the point of regulation. This point is where the LTC1707’s control loop looks for the information to keep the output voltage constant. In this demonstration board, this information point occurs between Pin 4, the GND of the LTC1707, and the output side of R7. These points correspond to the GND (E5) and V_{OSENSE} (E6) terminals of the board. Output voltage test leads should be attached directly to these terminals. The load should be placed between V_{OUT} (E7) and GND (E5). Measurements *should not* be taken at the end of test leads at the load. Refer to Figure 5 for the proper monitoring equipment configuration.

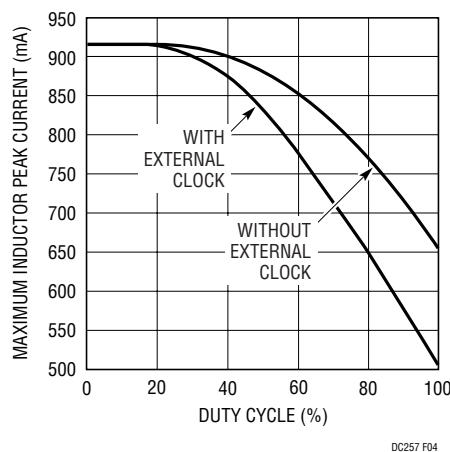

Figure 4. Maximum Inductor Peak Current Vs Duty Cycle

OPERATION

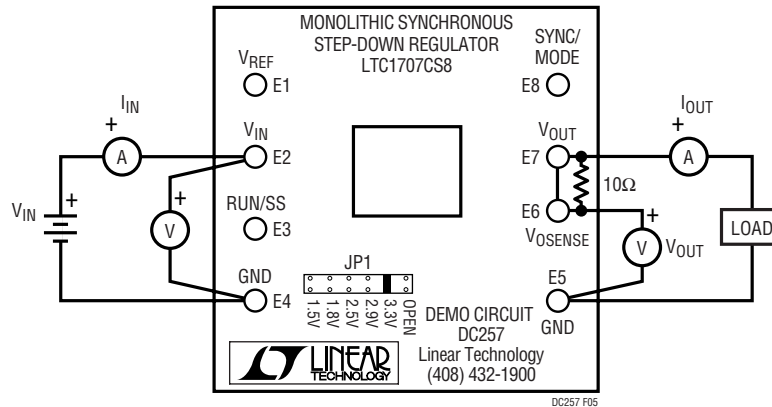

Figure 5. Proper Measurement Setup

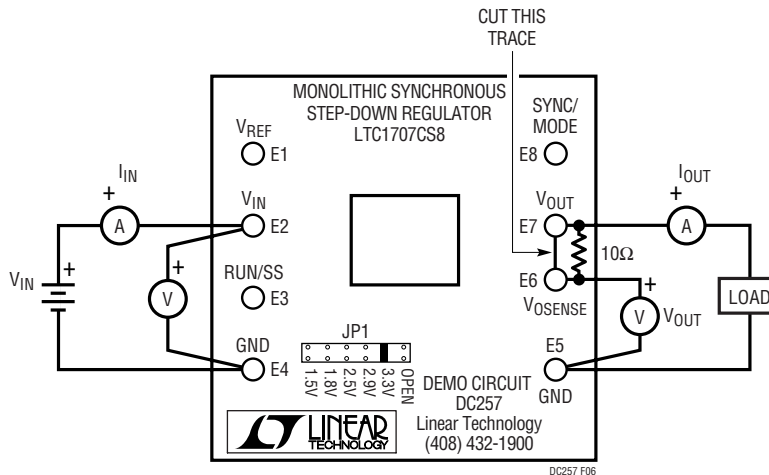

Figure 6. Remote Output Voltage Sense

This applies to line regulation (input-to-output voltage regulation) as well as load regulation tests. In doing the line regulation tests, always look at the input voltage across the input terminals.

For the purposes of these tests, the demonstration circuit should be powered from a regulated DC bench supply, so that variations on the DC input do not add errors to the regulation measurements.

REMOTE OUTPUT-VOLTAGE SENSING

Remote output-voltage sensing can be accomplished by modifying the PC board. A small PC trace connecting V_{OUT} to V_{OSENSE} must be cut, as shown in Figure 6. An external connection from V_{OSENSE} directly to the load must be made. To prevent uncertainty, there is a 10Ω resistor placed across the V_{OUT} and V_{OSENSE} terminals. Never, under any circumstance, allow V_{OSENSE} to float!

OPERATION

RUN/SOFT-START FUNCTION

The RUN/SS pin (E3) is a dual-purpose pin that provides the soft-start function and a means to shut down the LTC1707. Soft-start reduces surge currents from V_{IN} by gradually increasing the internal current limit. Power supply sequencing can also be accomplished using this pin.

An internal $2.25\mu\text{A}$ current source charges an external capacitor, C_{SS} . When the voltage on RUN/SS reaches 0.7V , the LTC1707 begins operating. As the voltage on RUN/SS continues to increase from 0.7V to 1.8V , the internal current limit also increases at a proportional linear rate. The current limit begins at 25mA (at $V_{\text{RUN/SS}} \leq 0.7\text{V}$) and ends at the Figure 4 value ($V_{\text{RUN/SS}} \geq 1.8\text{V}$). The output current thus increases slowly, charging the output capacitor. If RUN/SS has been pulled all the way to ground, there

is a delay before starting of approximately $310\text{ms}/\mu\text{F}$, followed by an additional $490\text{ms}/\mu\text{F}$ to reach full current. $C_{SS} = 0.1\mu\text{F}$ on this PC board.

Pulling the RUN/SS pin below 0.7V (0.4V min) puts the LTC1707 into a low quiescent current shutdown mode ($I_Q < 15\mu\text{A}$). See the LTC1707 data sheet for further information.

COMPONENT MANUFACTURERS

Table 2 is a partial list of manufacturers of components that can be used in LTC1707 applications. Using components other than the ones supplied on the demonstration board will require careful analysis to verify that all component specifications are not exceeded. Finally, recharacterizing the circuit for efficiency is necessary.

Table 2. List of Alternative Component Manufacturers

MANUFACTURER	DEVICE	PHONE	FAX
AVX	Capacitors	(843) 448-9411	(843) 448-1943
Central Semiconductor	Diodes	(516) 435-1110	(516) 435-1824
Coilcraft	Inductors	(847) 639-6400	(847) 639-1469
Coiltronics	Inductors	(561) 241-7876	(561) 241-9339
COMM CON	Connectors	(626) 301-4200	(626) 301-4212
Dale	Inductors	(605) 665-1627	(605) 665-0817
International Rectifier	Diodes	(310) 322-3331	(310) 322-3332
Motorola	Diodes	(800) 441-2447	(602) 413-6637
Murata-Erie	Capacitors	(814) 237-1431	(814) 238-0490
Sanyo	Capacitors	(619) 661-6835 (81) 0952-82-3959	(619) 661-1055 (81) 0952-82-4655
Sprague	Capacitors	(207) 324-4140	(207) 324-7223
Sumida	Inductors	(847) 956-0667 (81) 03-3607-5111	(847) 956-0702 (81) 03-3607-5114
TDK	Inductors	(847) 803-6100	(847) 803-6294
TAD	Resistors	(714) 255-9123	(714) 255-9291
Zetex	Diodes	(516) 543-7100	(516) 864-7630

PCB LAYOUT AND FILM

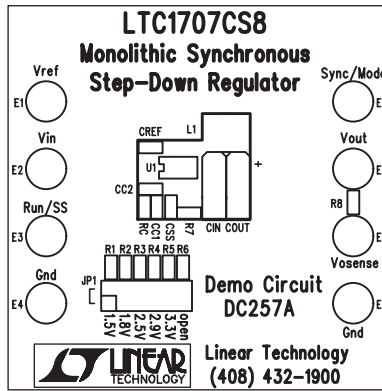

Component Side Silkscreen

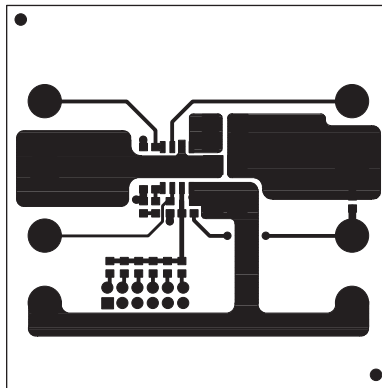

Component Side

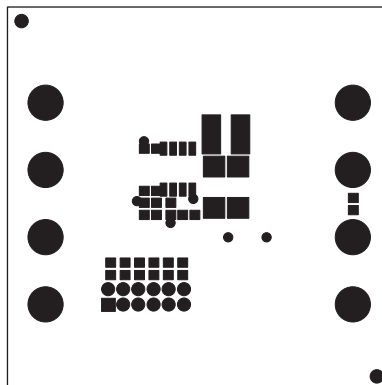

Component Side Solder Mask

PCB LAYOUT AND FILM

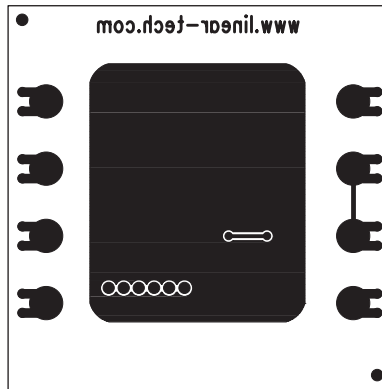

Solder Side

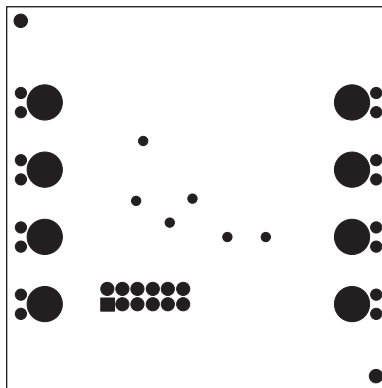

Solder Side Solder Mask

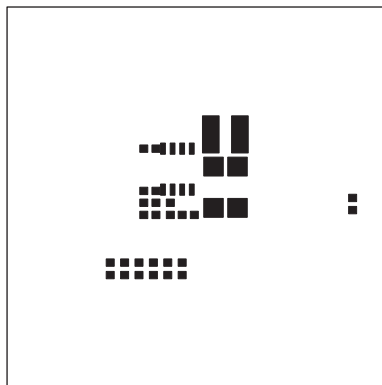

Pastemask

PC FAB DRAWING

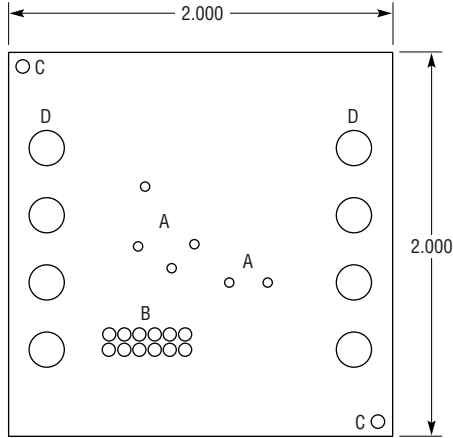

NOTES: UNLESS OTHERWISE SPECIFIED

1. MATERIAL: FR4 OR EQUIVALENT EPOXY,
2 OZ COPPER CLAD, THICKNESS 0.062 ±0.006
TOTAL OF 2 LAYERS
2. FINISH: ALL PLATED HOLES 0.001 MIN/0.0015 MAX
COPPER PLATE, ELECTRODEPOSITED TIN-LEAD COMPOSITION
BEFORE REFLOW. SOLDER MASK OVER BARE COPPER (SMOBC)
3. SOLDER MASK: BOTH SIDES USING SR1020 OR EQUIVALENT
4. SILKSCREEN: USING WHITE NONCONDUCTIVE EPOXY INK
5. ALL DIMENSIONS IN INCHES
6. SCORING

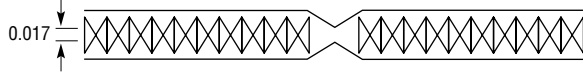

SYMBOL	DIAMETER	NUMBER OF HOLES	PLATED
A	0.020	6	PLTD
B	0.040	12	PLTD
C	0.072	2	NPLTD
D	0.095	8	PLTD
TOTAL HOLES		28	

X-ON Electronics

Largest Supplier of Electrical and Electronic Components

Click to view similar products for [Power Management IC Development Tools](#) category:

Click to view products by [Analog Devices](#) manufacturer:

Other Similar products are found below :

[EVAL-ADM1168LQEBZ](#) [EVB-EP5348UI](#) [MIC23451-AAAYFL EV](#) [MIC5281YMME EV](#) [DA9063-EVAL](#) [ADP122-3.3-EVALZ](#) [ADP130-0.8-EVALZ](#) [ADP130-1.2-EVALZ](#) [ADP130-1.5-EVALZ](#) [ADP130-1.8-EVALZ](#) [ADP1714-3.3-EVALZ](#) [ADP1716-2.5-EVALZ](#) [ADP1740-1.5-EVALZ](#) [ADP1752-1.5-EVALZ](#) [ADP1828LC-EVALZ](#) [ADP1870-0.3-EVALZ](#) [ADP1871-0.6-EVALZ](#) [ADP1873-0.6-EVALZ](#) [ADP1874-0.3-EVALZ](#) [ADP1882-1.0-EVALZ](#) [ADP199CB-EVALZ](#) [ADP2102-1.25-EVALZ](#) [ADP2102-1.875EVALZ](#) [ADP2102-1.8-EVALZ](#) [ADP2102-2-EVALZ](#) [ADP2102-3-EVALZ](#) [ADP2102-4-EVALZ](#) [ADP2106-1.8-EVALZ](#) [ADP2147CB-110EVALZ](#) [AS3606-DB](#) [BQ24010EVM](#) [BQ24075TEVM](#) [BQ24155EVM](#) [BQ24157EVM-697](#) [BQ24160EVM-742](#) [BQ24296MEVM-655](#) [BQ25010EVM](#) [BQ3055EVM](#) [NCV891330PD50GEVB](#) [ISLUSBI2CKIT1Z](#) [LM2744EVAL](#) [LM2854EVAL](#) [LM3658SD-AEV/NOPB](#) [LM3658SDEV/NOPB](#) [LM3691TL-1.8EV/NOPB](#) [LM4510SDEV/NOPB](#) [LM5033SD-EVAL](#) [LP38512TS-1.8EV](#) [EVAL-ADM1186-1MBZ](#) [EVAL-ADM1186-2MBZ](#)