

## DC308 INTRODUCTION

### Description

The LTC3401 is a high efficiency, step-up DC/DC converter that starts up from an input voltage as low as 1V. Once it is running, the LTC3401 is supplied from the output voltage and the input voltage can go well below 1V. The device includes a  $0.16\Omega$  N-channel MOSFET and a  $0.18\Omega$  P-channel synchronous rectifier, resulting in higher than 90% efficiency in many applications. Switching frequencies up to 3MHz can be programmed with an external resistor; the part can also be synchronized to an external clock.

Demonstration Circuit DC308 consists of two step-up converters using LTC3401. The top circuit runs at 3MHz; it is designed for minimum board size. This circuit is suitable for one cell to 3.3V applications where size is critical. The bottom circuit is a 1MHz converter, which gives a good trade-off between efficiency and size. The output voltage of the bottom circuit is jumper selectable between 3.3V and 5V.

### Quick Start Guide

1. Apply a voltage source to the input of the circuit between the  $V_{IN}$  and GND terminals. The circuit will start up at input voltage higher than 1V. Do not apply more than 5V to the input. Note that the boost circuit will regulate the output only when the input voltage is less than the desired output voltage.
2. Attach a voltmeter or oscilloscope probe between the  $V_{OUT}$  and GND terminals of the circuit to monitor the output. To start the circuit, remove the shunt that ties the shutdown pin to the GND.
3. Attach a load to the output. The available output power depends on the input voltage. Please refer to the performance summary for maximum current at different input and output voltages.
4. Proper hook-up is essential for accurate and meaningful evaluation of efficiency and regulation. Figure 1 shows the appropriate arrangement of supply, load, ammeters and voltmeters.

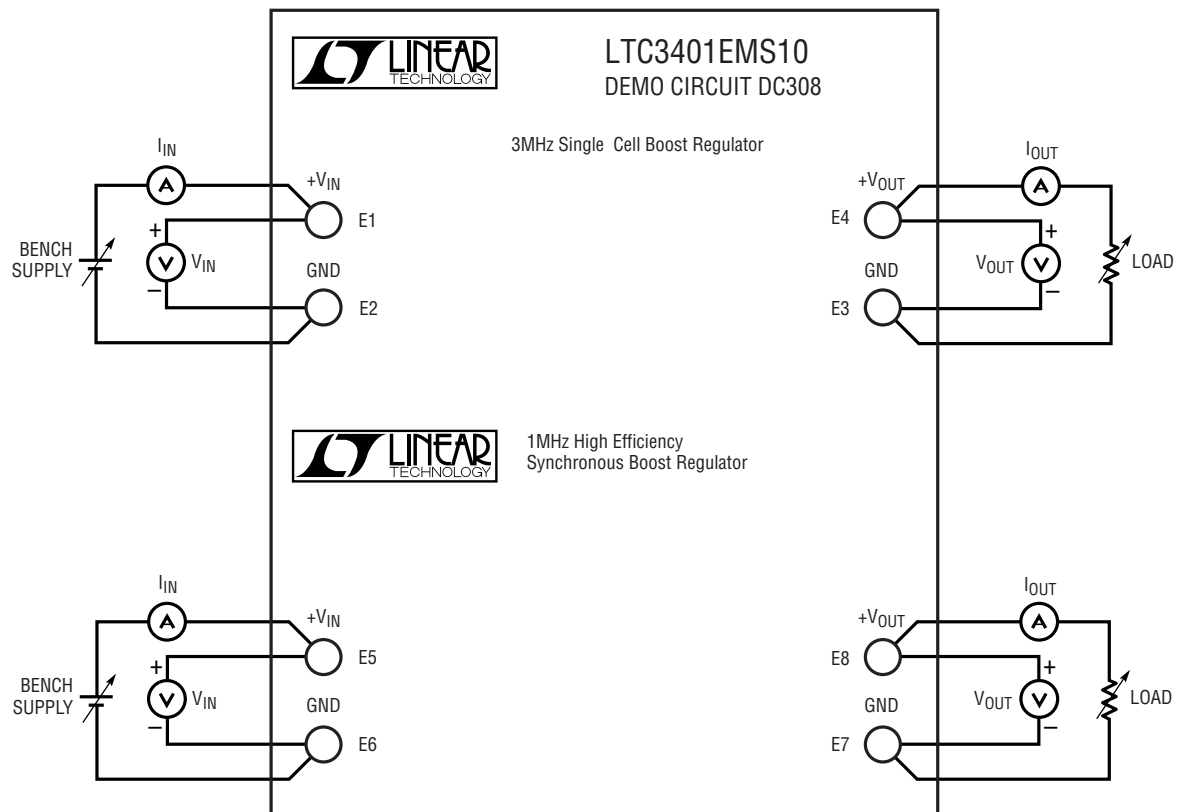

**Figure 1. DC308 Hookup Diagram**

**PERFORMANCE SUMMARY**

PARAMETER	CONDITION	VALUE
1MHz Boost Converter		
Maximum Load Current, Min	$V_{OUT} = 3.3V, V_{IN} = 0.9V$	175mA
	$V_{OUT} = 3.3V, V_{IN} = 1.8V$	395mA
	$V_{OUT} = 5.0V, V_{IN} = 1.8V$	240mA
	$V_{OUT} = 5.0V, V_{IN} = 2.7V$	370mA
3MHz Boost Converter		
Maximum Load Current, Min	$V_{OUT} = 3.3V, V_{IN} = 0.9V$	130mA

## PARTS LIST

REFERENCE DESIGNATOR	QUANTITY	PART NUMBER	DESCRIPTION	VENDOR	TELEPHONE
C1,C4,C6	3	JMK212BJ475MG	4.7μF 6.3V X5R Capacitor	TAIYO-YUDEN	(408) 573-4150
C2	1	04025A200JAT1A	20pF 50V NPO Capacitor	AVX	(843) 946-0362
C3	1	04025C471JAT1A	470pF 50V X7R Capacitor	AVX	(843) 946-0362
C5,C10	2	EMK107BJ104M	0.1μF 16V X5R Capacitor	TAIYO-YUDEN	(408) 573-4150
C7	1	06035A4R7JAT1A	4.7pF 50V NPO Capacitor	AVX	(843) 946-0362
C8	1	06035A471JAT1A	470pF 50V NPO Capacitor	AVX	(843) 946-0362
C9	1	JMK325BJ226MM	22uF 6.3V X5R Capacitor	TAIYO-YUDEN	(408) 573-4150
C11 (optional)	1	06035A150JAT1A	150pF 50V NPO Capacitor	AVX	(843) 946-0362
D1	1	MBRM120LT3	1A 20V Schottky Diode	ON Semiconductor	(602) 244-6600
D2,D4	2	1N4148WS	Fast Switching Diode	Diodes Incorporated	(805) 446-4800
D3	1	CMDSH2-3	200mA 30V Schottky Diode	Central Semiconductor	(631) 435-1110
L1	1	LB2016T1R0M	1μH Inductor	TAIYO-YUDEN	(408) 573-4150
L2	1	CR43-3R3M	3.3μH Inductor	Sumida	(847) 956-0667
R1,R3,R10,R12, R14	5	CR16-1004JM	1M 5% 0603 Resistor	AAC	(800) 508-1521
R2,R11	2	CR16-104JM	100k 5% 0603 Resistor	AAC	(800) 508-1521
R4	1	CR05-393JM	39k 5% 0402 Resistor	AAC	(800) 508-1521
R5	1	CR05-103JM	10k 5% 0402 Resistor	AAC	(800) 508-1521
R6	1	CR05-1004JM	1M 5% 0402 Resistor	AAC	(800) 508-1521
R7	1	CR05-1004FM	1M 1% 0402 Resistor	AAC	(800) 508-1521
R8	1	CR05-6043FM	1M 1% 0402 Resistor	AAC	(800) 508-1521
R13	1	CR16-823JM	82k 5% 0603 Resistor	AAC	(800) 508-1521
R15	1	CR16-303JM	30k 5% 0603 Resistor	AAC	(800) 508-1521
R16	1	CR16-1004FM	1M 1% 0603 Resistor	AAC	(800) 508-1521
R17	1	CR16-6043FM	604K 1% 0603 Resistor	AAC	(800) 508-1521
R18	1	CR16-7323FM	732K 1% 0603 Resistor	AAC	(800) 508-1521
E1-E8	8	2501-2	Turret, Testpoint	Mill-Max	(516) 922-6000
JP1	1	2802S-02-G1	2-Pin 1 Row 0.079"cc Header	Comm-Con	(626)-301-4200
J1,J2	2	2802S-05-G1	5-Pin 1 Row 0.079"cc Header	Comm-Con	(626)-301-4200
J1,J2,JP1	3	CCIJ2MM-138G	0.079"cc Shunt	Comm-Con	(626)-301-4200
U1,U2	2	LTC3401EMS10	IC	LTC	(408) 432-1900

## X-ON Electronics

Largest Supplier of Electrical and Electronic Components

*Click to view similar products for [Power Management IC Development Tools](#) category:*

*Click to view products by [Analog Devices](#) manufacturer:*

Other Similar products are found below :

[EVAL-ADM1168LQEBZ](#) [EVB-EP5348UI](#) [MIC23451-AAAYFL EV](#) [MIC5281YMME EV](#) [DA9063-EVAL](#) [ADP122-3.3-EVALZ](#) [ADP130-0.8-EVALZ](#) [ADP130-1.2-EVALZ](#) [ADP130-1.5-EVALZ](#) [ADP130-1.8-EVALZ](#) [ADP1714-3.3-EVALZ](#) [ADP1716-2.5-EVALZ](#) [ADP1740-1.5-EVALZ](#) [ADP1752-1.5-EVALZ](#) [ADP1828LC-EVALZ](#) [ADP1870-0.3-EVALZ](#) [ADP1871-0.6-EVALZ](#) [ADP1873-0.6-EVALZ](#) [ADP1874-0.3-EVALZ](#) [ADP1882-1.0-EVALZ](#) [ADP199CB-EVALZ](#) [ADP2102-1.25-EVALZ](#) [ADP2102-1.875EVALZ](#) [ADP2102-1.8-EVALZ](#) [ADP2102-2-EVALZ](#) [ADP2102-3-EVALZ](#) [ADP2102-4-EVALZ](#) [ADP2106-1.8-EVALZ](#) [ADP2147CB-110EVALZ](#) [AS3606-DB](#) [BQ24010EVM](#) [BQ24075TEVM](#) [BQ24155EVM](#) [BQ24157EVM-697](#) [BQ24160EVM-742](#) [BQ24296MEVM-655](#) [BQ25010EVM](#) [BQ3055EVM](#) [NCV891330PD50GEVB](#) [ISLUSBI2CKIT1Z](#) [LM2744EVAL](#) [LM2854EVAL](#) [LM3658SD-AEV/NOPB](#) [LM3658SDEV/NOPB](#) [LM3691TL-1.8EV/NOPB](#) [LM4510SDEV/NOPB](#) [LM5033SD-EVAL](#) [LP38512TS-1.8EV](#) [EVAL-ADM1186-1MBZ](#) [EVAL-ADM1186-2MBZ](#)