

QUICK START GUIDE FOR DEMONSTRATION CIRCUIT 326C

1.5A, 200KHZ HIGH VOLTAGE BUCK CONVERTER

LT1766EFE

DESCRIPTION

Demonstration circuit 326C is a monolithic step-down DC/DC switching converter featuring the LT1766EFE. The board is optimized for 5V output at up to 1A load current and a steady state input voltage range of 6V to 60V. With its wide input voltage range, 1.5A internal power switch, 200kHz switching frequency and thermally enhanced package, the LT1766EFE is a very versatile and powerful IC for DC/DC converters that require compact space, high efficiency and tolerance to high input voltage transients.

The LT1766EFE 200kHz switching frequency allows all of the components to be small, surface mount devices. Synchronization with an external clock of up to 700kHz is possible. The current-mode control topology creates fast transient response and good loop stability with a minimum number of external components. The low resistance internal power switch (0.2Ω) achieves high efficiencies of up to 90%. The SHDN pin can be used to

program undervoltage lockout or place the part in micropower shutdown, reducing supply current to $25\mu\text{A}$ by driving the pin low.

The LT1766EFE datasheet gives a complete description of the part, operation and applications information. The datasheet must be read in conjunction with this Quick Start Guide for demonstration circuit 326C. In particular, the datasheet section on 'Thermal Calculations' is important for estimating whether a given application's combination of input voltage, load current and frequency will cause the LT1766EFE to exceed its absolute maximum rated junction temperature. The LT1766EFE is assembled in a small 16-pin thermally enhanced package with exposed pad where proper board layout is essential for maximum thermal performance. See the datasheet section 'Layout Considerations'.

Design files for this circuit board are available. Call the LTC factory.

Table 1. Typical Performance Summary ($T_A = 25^\circ\text{C}$)

PARAMETER	CONDITION	VALUE
Steady State Input Voltage Range	$V_{OUT} = 5\text{V}, I_{OUT} \leq 1\text{A}$	6–60V
Maximum Transient Input Voltage		60V
V_{OUT}	$V_{IN} = 6\text{V to } 60\text{V}, I_{OUT} \leq 1\text{A}$	$5\text{V} \pm 3\%$
Maximum Output Current	$V_{OUT} = 5\text{V}$	1A
Output Voltage Ripple	$V_{IN} = 12\text{V}, I_{OUT} = 1\text{A}, V_{OUT} = 5\text{V}$	20mV _{PK-PK}
	$V_{IN} = 48\text{V}, I_{OUT} = 1\text{A}, V_{OUT} = 5\text{V}$	32mV _{PK-PK}
Switching Frequency	$V_{IN} = 6\text{V to } 60\text{V}, I_{OUT} \leq 1\text{A}$	200kHz
Efficiency	$V_{IN} = 12\text{V}, I_{OUT} = 1\text{A}, V_{OUT} = 5\text{V}$	87%
	$V_{IN} = 48\text{V}, I_{OUT} = 1\text{A}, V_{OUT} = 5\text{V}$	80%

QUICK START PROCEDURE

Demonstration circuit 326C is easy to set up to evaluate the performance of the LT1766EFE. Refer to Figure 1 for proper measurement equipment setup and follow the procedure below:

NOTE: Make sure that the input voltage does not exceed 60V.

NOTE: The synchronization and shutdown functions are optional and their pins can be left floating (disconnected) if their functions are not being used.

NOTE: Do not hot-plug the input voltage terminal VIN. The absolute maximum voltage on VIN is 60V and hot-plugging a power supply through wire leads to the demonstration circuit can cause the voltage on the extremely low-ESR ceramic input capacitor to ring to twice its DC value. This is due to high currents instantaneously generated in the inductive supply leads from an input voltage step on the low-ESR ceramic input capacitor. A bulky higher-ESR capacitor, and an additional inductive filter can be added to the circuit to dampen hot-plug transient ringing. See *Application Note 88* for more details.

1. Connect the power supply (with power off), load and meters as shown in Figure 1.
2. After all connections are made, turn on input power and verify that the output voltage is 5V.

NOTE: If the output voltage is too low, temporarily disconnect the load to make sure that the load is not set too high.

3. Once the proper output voltages are established, adjust the loads within the operating range and observe the output voltage regulation, ripple voltage, efficiency and other parameters.

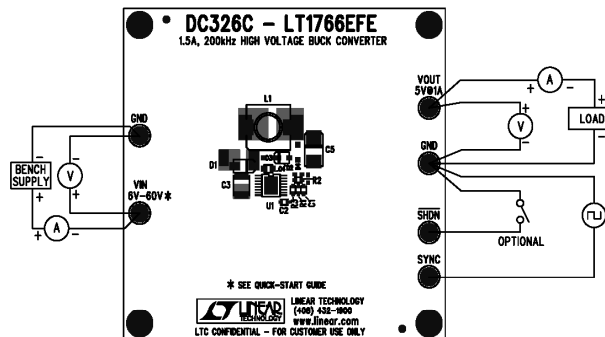

Figure 1. Proper Measurement Equipment Setup

CUSTOM OPTIONS

OUTPUT VOLTAGE

The components assembled on the board are optimized for a wide input voltage range and a 5V output. The feedback resistors (R2, R3) can be changed to adjust the output voltage according to the following equation:

$$V_{OUT} = 1.22 (1 + R2/R3)$$

The Thevenin equivalent resistance seen at the FB pin should be less than 3.8k to maximize frequency foldback during start-up and short-circuit.

For output voltages below 3V, the boost diode should be moved from D2 to D3 to provide at least the minimum boost voltage required for the internal power switch. Make sure that the boost capacitor (C4) has a voltage rating (1) greater than the output voltage (when the boost diode is placed in D2) or (2) greater than the input voltage (when the boost diode is placed in position D3).

For output voltages greater than 5V, the optional 'blocking' zener diode D4 can be used to reduce the boost voltage across C4 to some lower voltage between 3V and 5V. The diode transfers power dissipation from inside the LT1766EFE to the diode on the demonstration circuit, outside the LT1766EFE, allowing higher ambient temperature operation of the part. Maintaining boost voltage between 3V and 5V maximizes efficiency and

optimizes control of the power switch. It is recommended that a CMHZ5236B zener diode is used in D4 when $V_{OUT} = 12V$. To properly install D4, the small trace shorting the anode to the cathode of D4 on the board must be opened (an Exacto knife works well) before D4 is soldered to the board. In the 'Thermal Calculations' section of the datasheet, the new value for boost voltage ($V_{OUT} - V_Z$) should be accounted for when calculating junction temperature.

$$P_{DISS(BOOST)} = (V_{OUT} - V_Z) * (I_{SW}/36) * V_{OUT}/V_{IN}$$

CERAMIC OUTPUT CAPACITOR

The output capacitor (C5) is a 100 μ F tantalum 10V AVX TPS series with 100m Ω ESR. This tantalum capacitor has low ESR, resulting in low output voltage ripple (20mV_{PK-PK} with 12V_{IN}, 5V_{OUT}, 1A load current).

For even lower output voltage ripple, a ceramic output capacitor can be used because the ceramic output capacitor will have much lower ESR than the tantalum. A 47 μ F, 6.3V X5R or better ceramic capacitor can be used in place of C5 for solutions with 5V_{OUT} or below. R1, C1, and C2 (and C8) may need to be adjusted to optimize control loop stability for different types of output capacitors and different output voltages. The 3.3V_{OUT} ceramic output capacitor solution in Figure 6 has 15mV_{PK-PK} output voltage ripple with 12V_{IN} and 1A load current.

For more details, see the 'Output Capacitor' and 'Ceramic Capacitors' sections of the Applications Data in the datasheet.

COMPENSATION

Demonstration circuit 326C has a frequency compensation network that is optimized for the tantalum output capacitor C5, the wide input voltage range 6V to 60V, and 5V output. Improved loop bandwidth can be achieved for various output voltages, output capacitors, and input voltage ranges by adjusting R1, C1, and C2. Additional optional component locations for a feedforward capacitor (C8) and a resistor (R4 for short circuit feedback pin protection when C8 is used) are located in parallel with R2. For more information, see the 'Frequency Compensation' section in the Applications Information in the datasheet, Application Note 19, or Application Note 76.

SOFT START

When the ratio of the input voltage divided by the output voltage (plus the forward voltage of the catch diode) is greater than ten

$$V_{IN}/(V_{OUT} + V_F) > 10$$

the soft start circuit made up of components C9, R5, R6, and Q1 should be used to control inductor current during startup. The soft start circuit is also useful for controlling output voltage rise time and overshoot without affecting transient response performance during normal operation of the converter. The soft start circuit is covered in detail in 'Buck Converter with Adjustable Soft Start' in the datasheet.

QUICK START GUIDE FOR DEMONSTRATION CIRCUIT 326C

1.5A, 200KHZ HIGH VOLTAGE BUCK CONVERTER

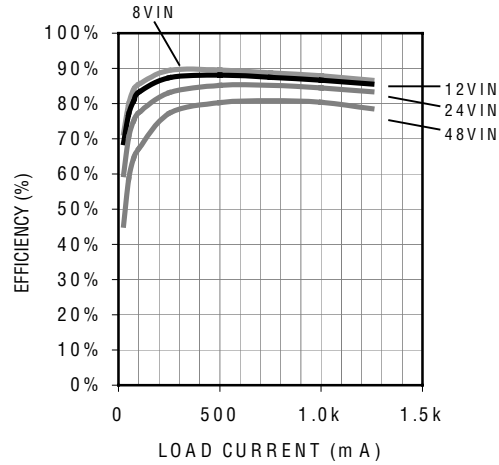

Figure 2. DC326C Typical Efficiency ($T_A = 25^\circ\text{C}$)

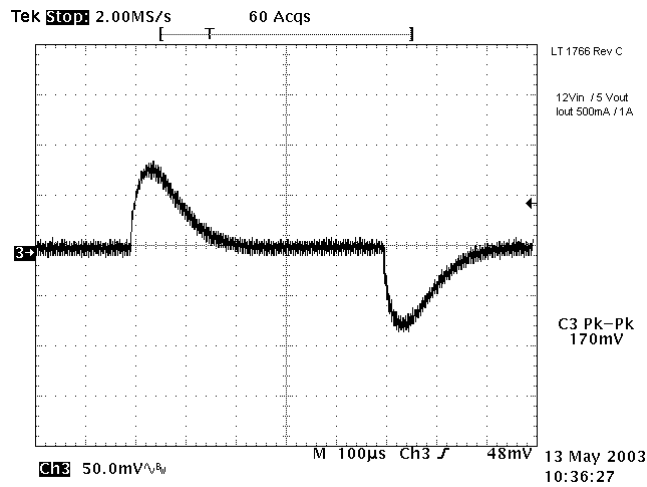

Figure 3. DC326C Typical Step Load Response ($I_{OUT} = 500\text{mA}$ to 1A , $V_{IN} = 12\text{V}$, $T_A = 25^\circ\text{C}$, $V_{OUT} = 5\text{V}$) CH3 is V_{OUT} (AC)

QUICK START GUIDE FOR DEMONSTRATION CIRCUIT 326C

1.5A, 200KHZ HIGH VOLTAGE BUCK CONVERTER

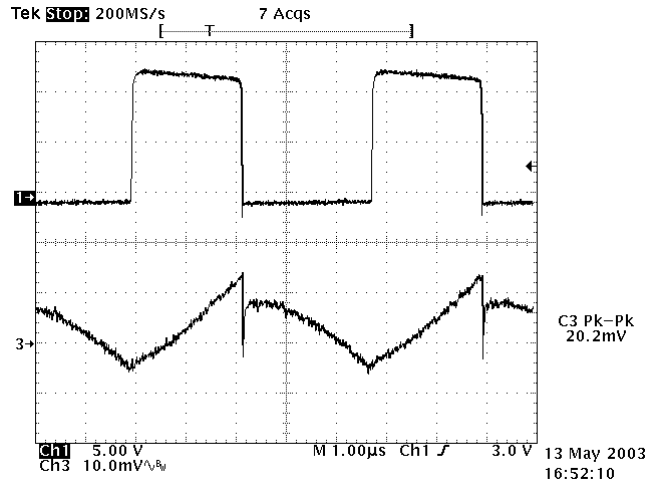

Figure 4. DC326C Typical Output Voltage Ripple
($I_{OUT} = 1A$, $V_{IN} = 12V$, $V_{OUT} = 5V$, $T_A = 25^\circ C$) CH3 is V_{OUT} ripple, CH1 is V_{SW}

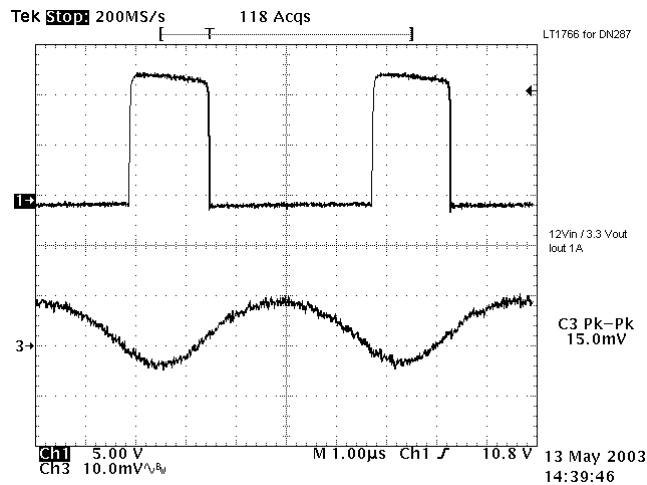

Figure 5. Typical Output Voltage Ripple of Ceramic Output Capacitor Solution in Figure 6 ($I_{OUT} = 1A$, $V_{IN} = 12V$, $V_{OUT} = 3.3V$, $T_A = 25^\circ C$) CH1 is V_{sw} , CH3 is V_{OUT} ripple

QUICK START GUIDE FOR DEMONSTRATION CIRCUIT 326C

1.5A, 200KHZ HIGH VOLTAGE BUCK CONVERTER

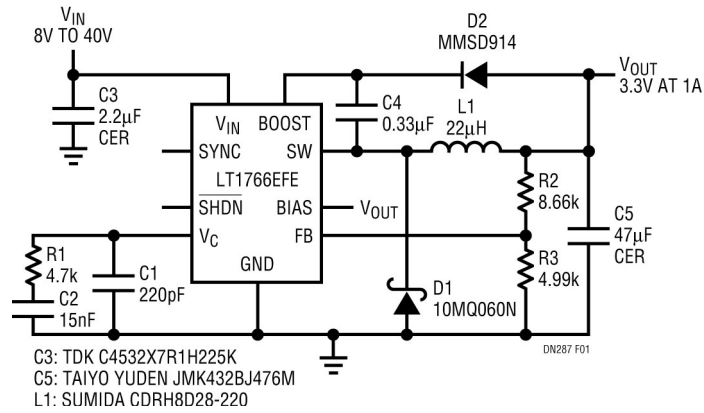
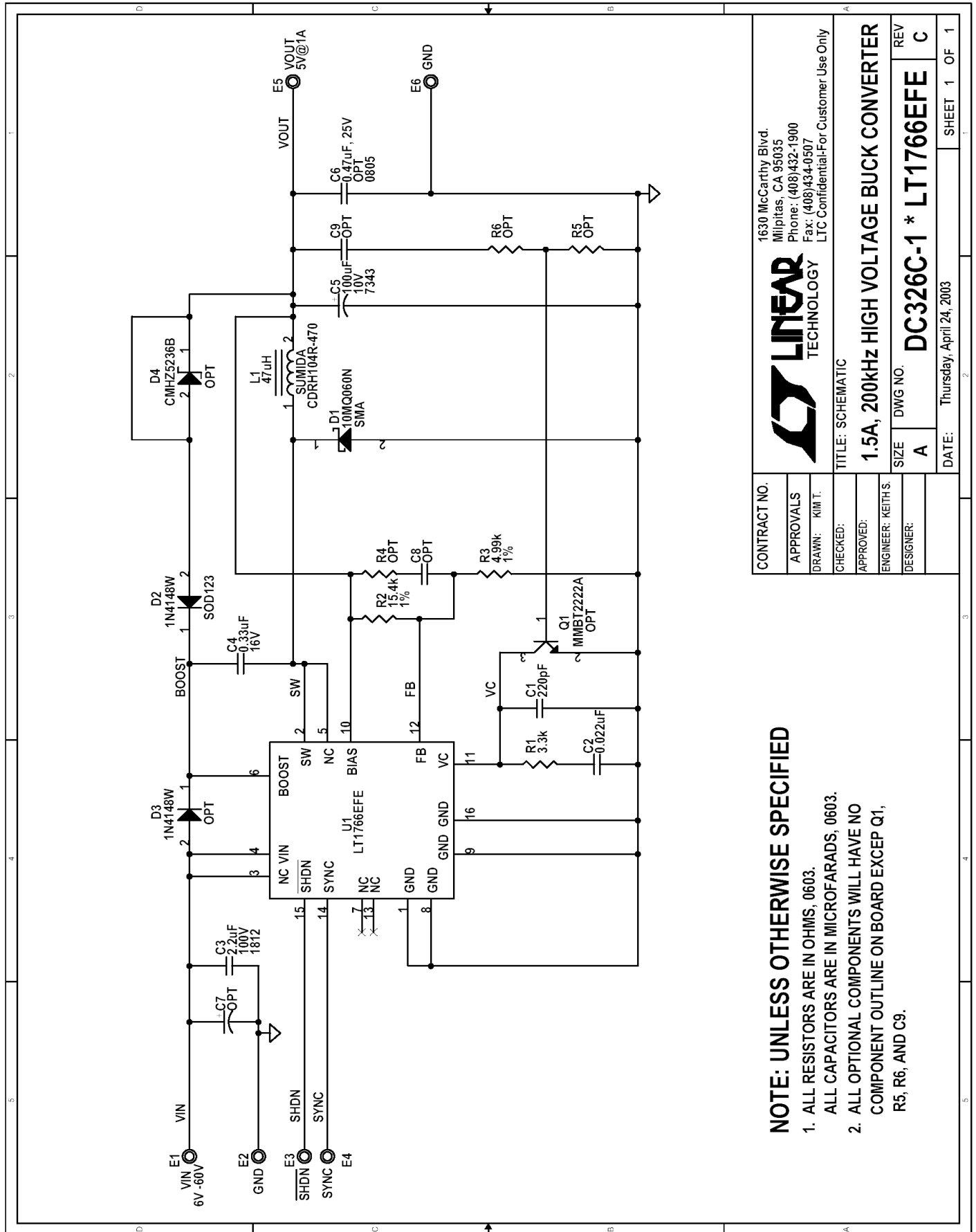

Figure 6. $8V_{IN}$ to $40V_{IN}$, $3.3V_{OUT}$, $1A_{OUT}$ All-Ceramic Capacitor Solution with 3.0mm Maximum Height

QUICK START GUIDE FOR DEMONSTRATION CIRCUIT 326C

1.5A, 200KHZ HIGH VOLTAGE BUCK CONVERTER



CONTRACT NO.		1630 McCarthy Blvd. Milpitas, CA 95035 Phone: (408)432-1900 Fax: (408)434-0507 LTC Confidential-For Customer Use Only	
APPROVALS		LINEAR TECHNOLOGY	
DRAWN: KIM.T.		TITLE: SCHEMATIC	
CHECKED:		1.5A, 200KHZ HIGH VOLTAGE BUCK CONVERTER	
APPROVED:		ENGINEER: KEITH.S.	
ENGINEER: KEITH.S.		DESIGNER:	
DESIGNER:		SIZE DWG NO. DC326C-1 * LT1766EFE	
DATE: Thursday, April 24, 2003		REV C	
SHEET 1 OF 1			

NOTE: UNLESS OTHERWISE SPECIFIED

1. ALL RESISTORS ARE IN OHMS, 0603.
ALL CAPACITORS ARE IN MICROFARADS, 0603.
2. ALL OPTIONAL COMPONENTS WILL HAVE NO COMPONENT OUTLINE ON BOARD EXCEPT Q1, R5, R6, AND C9.

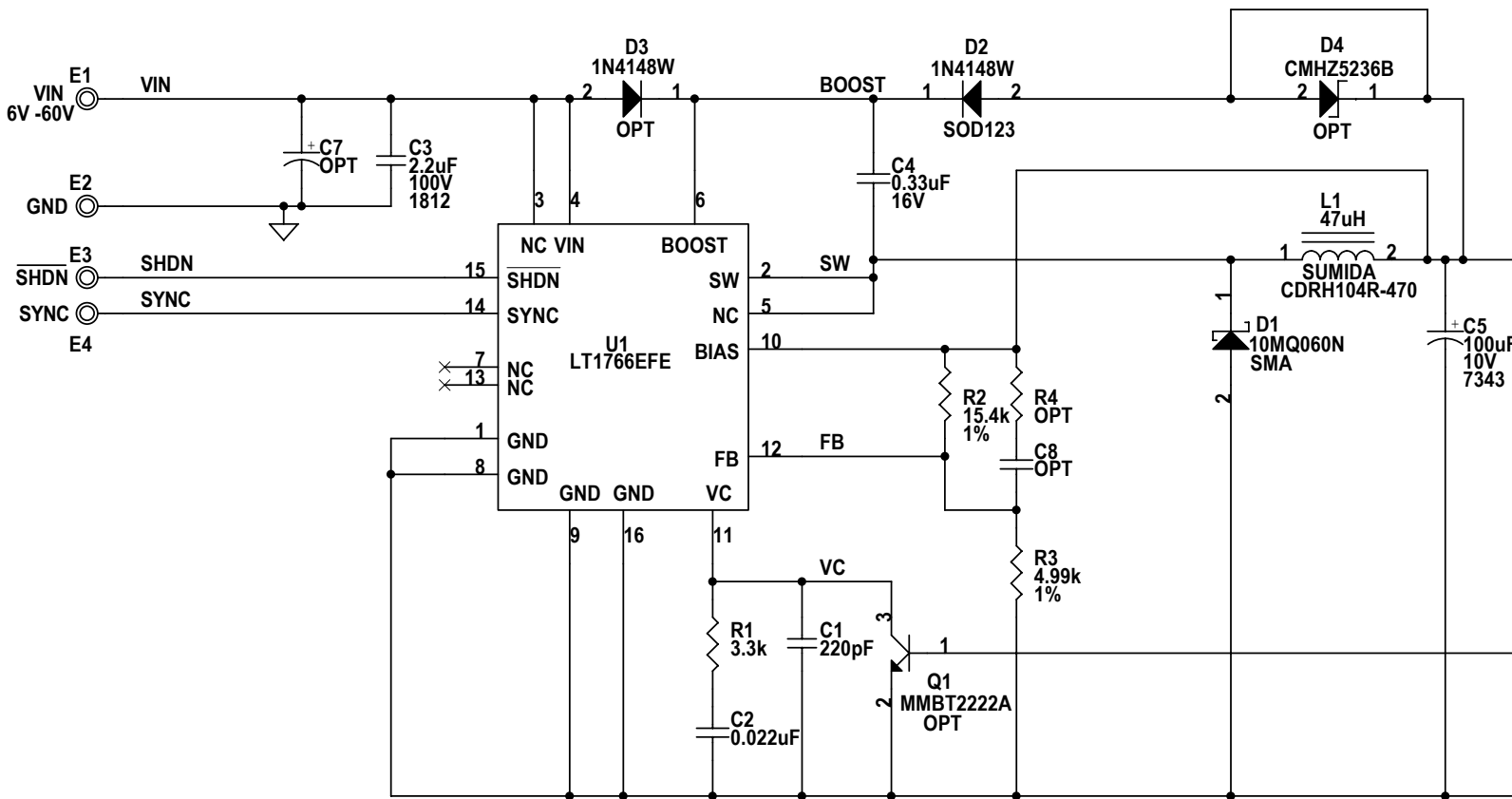

NOTE: UNLESS OTHERWISE SPECIFIED

1. ALL RESISTORS ARE IN OHMS, 0603.
ALL CAPACITORS ARE IN MICROFARADS, 0603.
2. ALL OPTIONAL COMPONENTS WILL HAVE NO COMPONENT OUTLINE ON BOARD EXCEPT Q1, R5, R6, AND C9.

CONTRACT NO.

APPROVALS

DRAWN: KIM T.

CHECKED:

APPROVED:

ENGINEER: KEITH S.

DESIGNER:



TITLE: SCHEMATIC

1.5A, 200kHz HIGH VO

SIZE
A

DWG NO.

DC3260

DATE: Thursday, April 24, 2003

Linear Technology Corporation

LT1766EFE

1.5A, 200kHz HIGH VOLTAGE BUCK CONVERTER

ENG: KEITH SZOLUSHA

Item	Qty	Reference	Part Description	Manufacture /
1	1	C1	CAP, NPO 220pF 25V 10%	AVX, 06033A221KAT1A
2	1	C2	CAP, X7R 0.022uF 16V 10%	AVX, 0603YC223KAT1A
3	1	C3	CAP, X7R 2.2uF 100V, 80%, 1812	TDK, C4532X7R2A225K
4	1	C4	CAP, X5R 0.33uF 10V 10%	AVX, 0603ZD334KAT1A
5	1	C5	CAP, TANT. 100uF 10V 20%, 7343	AVX, TPSD107M010R0100
6	0	C6	CAP, Y5V 0.47uF 25V, 80%	OPT
7	0	C7	CAP, C SIZE, 6032	OPT
8	0	C8,C9	CAP, 0603	OPT
9	1	D1	DIODE SCHOTTKY,1.5A, 60V,SMA-DIODE	IR, 10MQ060N
10	1	D2	DIODE, 200mA, 100V, SOD123	DIODES INC., 1N4148W
11	0	D3	DIODE, 200mA, 100V, SOD123	DIODES INC., 1N4448W
12	0	D4	DIODE ZENER, SOD123	CENTRAL SEMI., CMHZ52
13	6	E1-E6	TP, TURRET, .094"	MILL-MAX, 2501-2
14	1	L1	IND, SMT, 47uH, L-CDRH104R	SUMIDA, CDRH104R-470N
15	0	Q1	TRANS, MMBT2222A, SOT23	DIODES INC., MMBT2222A
16	1	R1	RES, 3.3k 5%, 0603	AAC, CR16-332JM
17	1	R2	RES, 15.4k 1%, 0603	AAC, CR16-1542FM
18	1	R3	RES, 4.99k 1%, 0603	AAC, CR16-4991FM
19	0	R4,R5,R6	RES, 0603	OPT
20	1	U1	IC, LT1766EFE, TSSOPFE16	LINEAR TECH., LT1766EF
21	4	MTG HOLES AT 4 CORNERS	STANDOFF, NYLON HEX #4-40 x 1/4"	MICRO PLASTICS, #14HT
22	4		SCREW, #4-40 x 1/4	ANY
NOTES: UNLESS OTHERWISE SPECIFIED				
1. ALL RESISTORS ARE IN OHMS.				
2. INSTALL 4 STANDOFFS AT 4 CORNERS OF BOARD AND ON THE BOTTOM SIDE.				

X-ON Electronics

Largest Supplier of Electrical and Electronic Components

Click to view similar products for [Power Management IC Development Tools](#) category:

Click to view products by [Analog Devices](#) manufacturer:

Other Similar products are found below :

[EVAL-ADM1168LQEBZ](#) [EVB-EP5348UI](#) [MIC23451-AAAYFL EV](#) [MIC5281YMME EV](#) [DA9063-EVAL](#) [ADP122-3.3-EVALZ](#) [ADP130-0.8-EVALZ](#) [ADP130-1.2-EVALZ](#) [ADP130-1.5-EVALZ](#) [ADP130-1.8-EVALZ](#) [ADP1714-3.3-EVALZ](#) [ADP1716-2.5-EVALZ](#) [ADP1740-1.5-EVALZ](#) [ADP1752-1.5-EVALZ](#) [ADP1828LC-EVALZ](#) [ADP1870-0.3-EVALZ](#) [ADP1871-0.6-EVALZ](#) [ADP1873-0.6-EVALZ](#) [ADP1874-0.3-EVALZ](#) [ADP1882-1.0-EVALZ](#) [ADP199CB-EVALZ](#) [ADP2102-1.25-EVALZ](#) [ADP2102-1.875EVALZ](#) [ADP2102-1.8-EVALZ](#) [ADP2102-2-EVALZ](#) [ADP2102-3-EVALZ](#) [ADP2102-4-EVALZ](#) [ADP2106-1.8-EVALZ](#) [ADP2147CB-110EVALZ](#) [AS3606-DB](#) [BQ24010EVM](#) [BQ24075TEVM](#) [BQ24155EVM](#) [BQ24157EVM-697](#) [BQ24160EVM-742](#) [BQ24296MEVM-655](#) [BQ25010EVM](#) [BQ3055EVM](#) [NCV891330PD50GEVB](#) [ISLUSBI2CKIT1Z](#) [LM2744EVAL](#) [LM2854EVAL](#) [LM3658SD-AEV/NOPB](#) [LM3658SDEV/NOPB](#) [LM3691TL-1.8EV/NOPB](#) [LM4510SDEV/NOPB](#) [LM5033SD-EVAL](#) [LP38512TS-1.8EV](#) [EVAL-ADM1186-1MBZ](#) [EVAL-ADM1186-2MBZ](#)