

## DESCRIPTION

Demonstration Circuit 383B is multipurpose demonstration board featuring the LT1930 and LT1931. The demo board offers three separate DC/DC converters. The Boost circuit is designed to convert 5V input to 12V output at 300mA maximum load. The SEPIC circuit generates constant 12V/300mA output with 10V~16V variable input. The Inverter circuit is designed for applications requiring negative 12V/350mA from a positive 12V input. All three circuits are designed to demonstrate the advantages of the 1.2MHz switching frequency, the internal 36V/1A switch, wide input voltage range and small circuit size. These circuits are intended for space-conscious applications such as digital cameras, cellular phones, palmtop computers and LCD displays. The 1.2MHz switching

frequency, 1A integrated switch, small circuit size, and low component count makes the LT1930 and LT1931 suitable for use in many other applications, such as PC cards, miniature disk drives, xDSL power supplies, flash memory products and local 5V or 12V supplies. The LT1930/LT1931 datasheets give complete descriptions of the parts, their operation and application information. The datasheets must be read in conjunction with this quick start guide for working on or modifying any circuit on the demo circuit 383B.

**Design files for this circuit board are available. Call the LTC factory.**

LT is a trademark of Linear Technology Corporation

**Table 1. Performance Summary** SPECIFICATIONS ARE AT TA = 25°C

SYMBOL	PARAMETER FOR BOOST CONVERTER	CONDITIONS	MIN	TYP	MAX	UNITS
V <sub>IN</sub>	Input Supply Range			5		V
V <sub>OUT</sub>	Output Voltage Accuracy	V <sub>IN</sub> = 5V, I <sub>LOAD</sub> = 300mA	11.76	12	12.24	V
Ripple		V <sub>IN</sub> = 5V, I <sub>LOAD</sub> = 300mA		50		mV
F <sub>s</sub>	Switching Frequency			1.2		MHz
SYMBOL	PARAMETER FOR SEPIC CONVERTER	CONDITIONS	MIN	TYP	MAX	UNITS
V <sub>IN</sub>	Input Supply Range		10		16	V
V <sub>OUT</sub>	Output Voltage Accuracy	V <sub>IN</sub> = 10V, I <sub>LOAD</sub> = 300mA	11.76	12	12.24	V
Ripple		V <sub>IN</sub> = 10.5V, I <sub>LOAD</sub> = 300mA		50		mV
F <sub>s</sub>	Switching Frequency			1.2		MHz
SYMBOL	PARAMETER FOR INVERTING CONVERTER	CONDITIONS	MIN	TYP	MAX	UNITS
V <sub>IN</sub>	Input Supply Range			12		V
V <sub>OUT</sub>	Output Voltage Accuracy	V <sub>IN</sub> = 12V, I <sub>LOAD</sub> = 350mA	-11.76	-12	-12.24	V
Ripple		V <sub>IN</sub> = 12V, I <sub>LOAD</sub> = 350mA		40		mV
F <sub>s</sub>	Switching Frequency			1.2		MHz

---

## QUICK START PROCEDURES

Refer to **Figures 1–4** for proper measurement equipment setup and follow the procedure outlined below:

The equipment setup for the three circuits is very similar. They all have three pins marked “Vin,” “Gnd” and “Vout,” and a jumper marked “on/off” for demonstrating the shutdown function.

For the best accuracy it is important to connect true RMS reading voltmeters directly to the PCB terminals, where the input and output voltage are connected. True RMS reading ammeters should be used for current measurements.

The SHUTDOWN function is tested by placing the jumper in the “off” position. This will short the shutdown pin to ground and turn off the internal switch of the LT1930/LT1931. Placing the jumper in the “on” position will return the circuit to normal operation.

### ***Quick Start for the Boost Circuit:***

1. Before turning on the power, connect a 5V, 1A bench supply to the Vin and Gnd terminals and connect the output loads (up to 300mA). When an electronic load is used, decrease load current setting to less than 100mA until the output voltage has stabilized. Connect an oscilloscope and meters to the Vout and Gnd terminals, as shown in Figure 1.

2. Turn on the input power supply and observe the output. The DC383 Boost converter is programmed to generate 12V from 5V input. The circuit will deliver up to 300mA at 12V.

3. The current limit is tested by increasing the load past 400mA. The current limit will take effect when the peak switch current becomes higher than ~1A. When the current limit is exceeded, the output volt-

age will drop drastically. Return to normal operation by removing the load.

### ***Quick Start for the SEPIC Circuit:***

1. Before turning on the power, connect a 16V, 1A bench supply to the Vin and Gnd terminals and connect the output loads (up to 300mA). When an electronic load is used, decrease load current setting to less than 100mA until the output voltage has stabilized. Connect oscilloscope and meters to the Vout and Gnd terminals, as shown in Figure 2.

2. Turn on the input power supply and observe the output. The DC383 SEPIC Circuit is programmed to generate 12V from a 10V–16V input. Vary the input voltage to test the line regulation. The circuit is designed to deliver up to 300mA at a 12V output.

3. The current limit is tested by increasing the load past 400mA. The current limit will take effect when the peak switch current becomes higher than ~1A. When the current limit is exceeded, the output voltage will drop drastically. Return to normal operation by removing the load.

### ***Quick Start for the Inverter Circuit:***

1. Before turning on the power, connect a 12V, 1A bench supply to the Vin and Gnd terminals and connect the output loads (up to 300mA). When an electronic load is used, decrease load current setting to less than 100mA until the output voltage has stabilized. Connect oscilloscope and meters to the Vout and Gnd terminals, as shown in Figure 3.

2. Turn on the input power supply and observe the output. The DC383 Inverter Circuit is programmed to generate –12V from a +12V input. The circuit will deliver up to 300mA at –12V.

3. The current limit is tested by increasing the load past 500mA. The current limit will take effect when the peak switch current becomes higher than ~1A.

When the current limit is exceeded, the output voltage will drop drastically. Return to normal operation by removing the load.

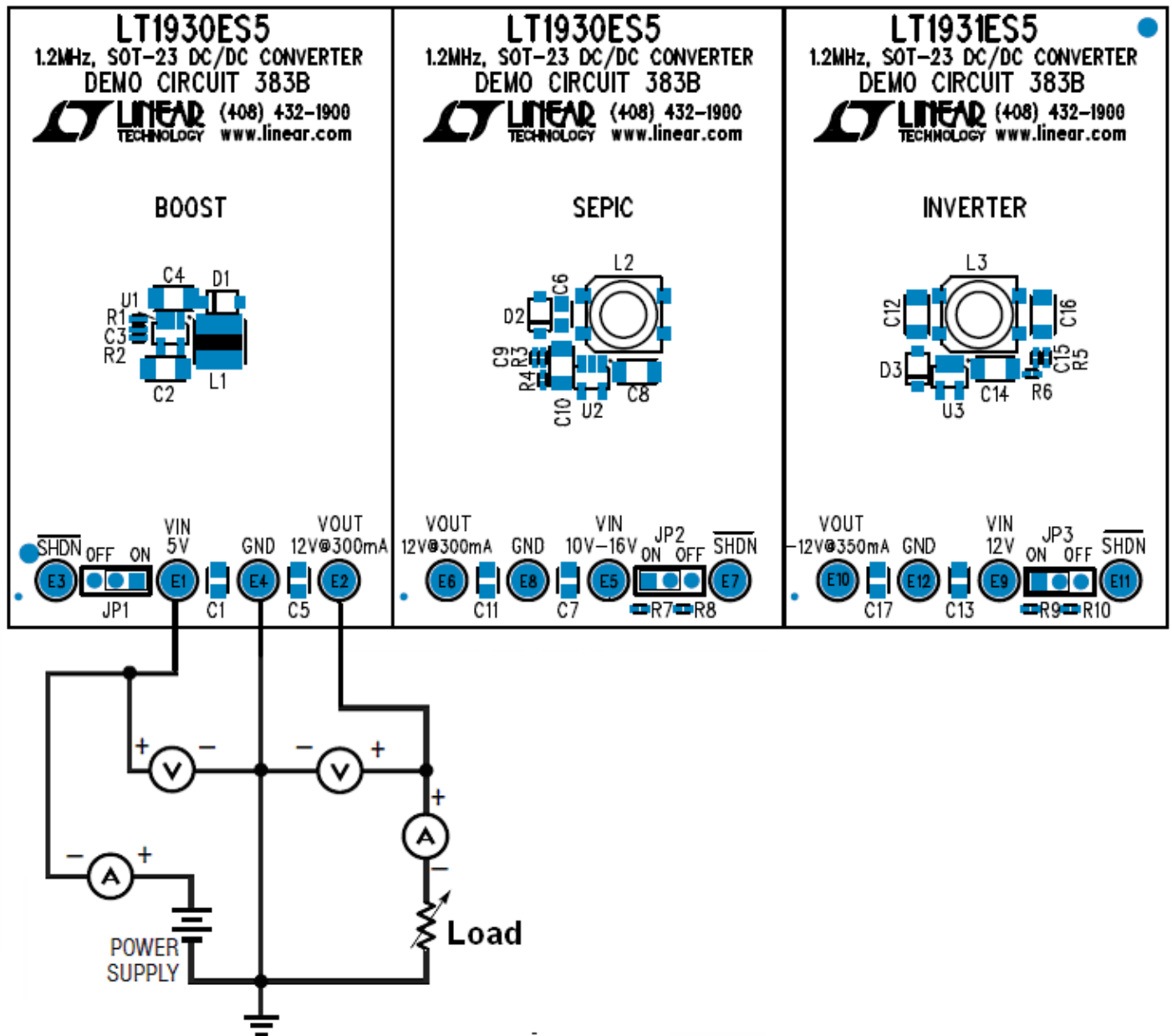

Figure 1. Proper Measurement Equipment Setup for Boost Converter

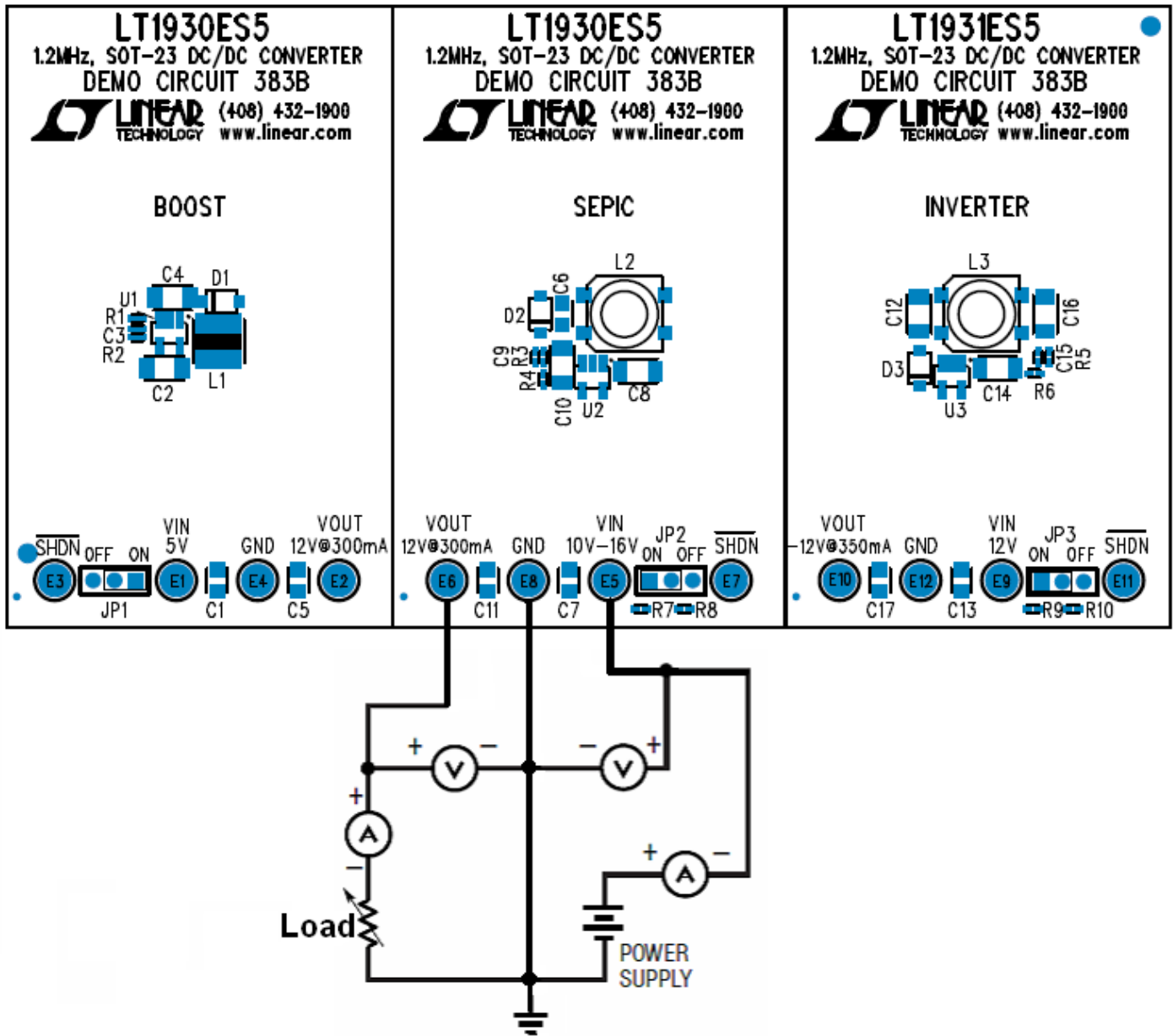

Figure 2. Proper Measurement Equipment Setup for Sepic Converter

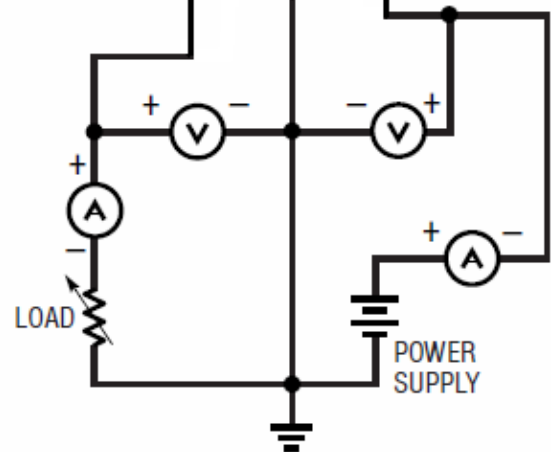
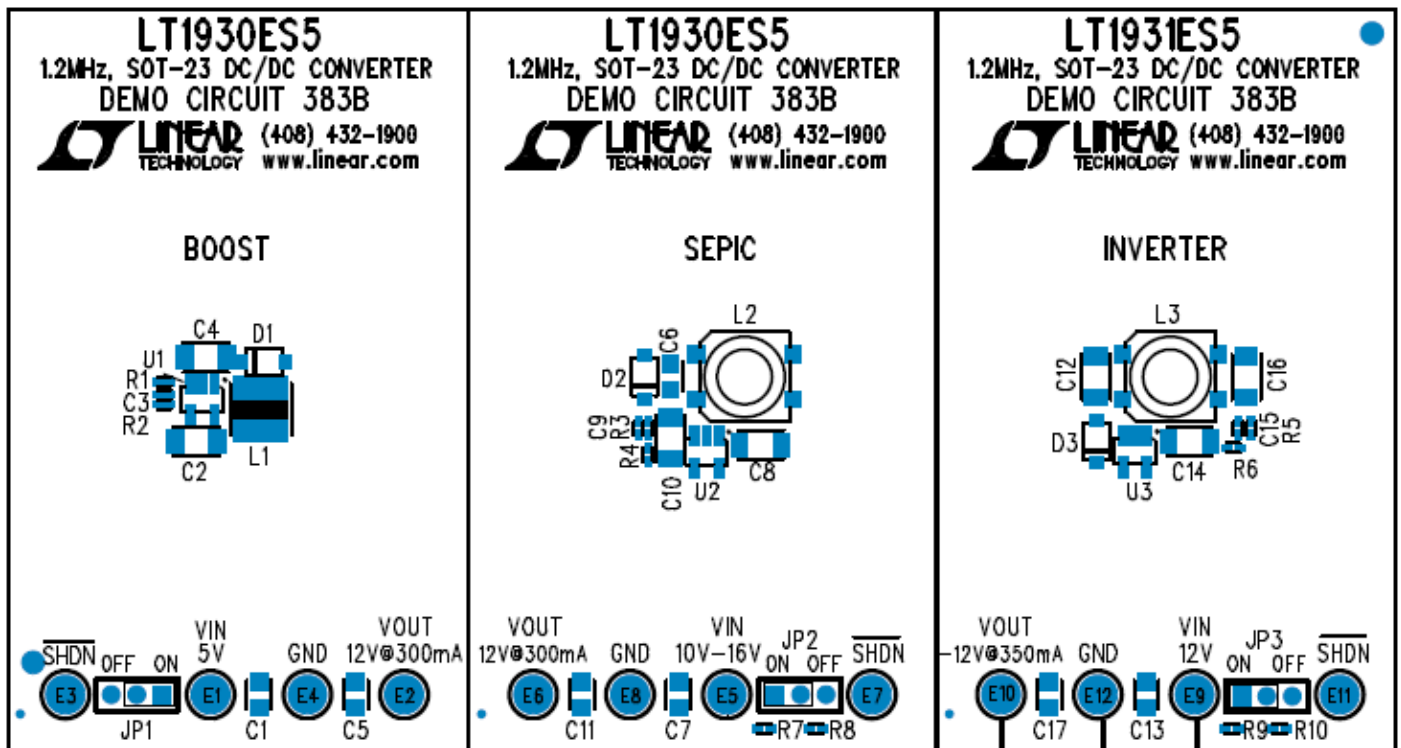

Figure 3. Proper Measurement Equipment Setup for Inverting Converter

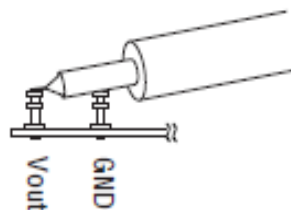
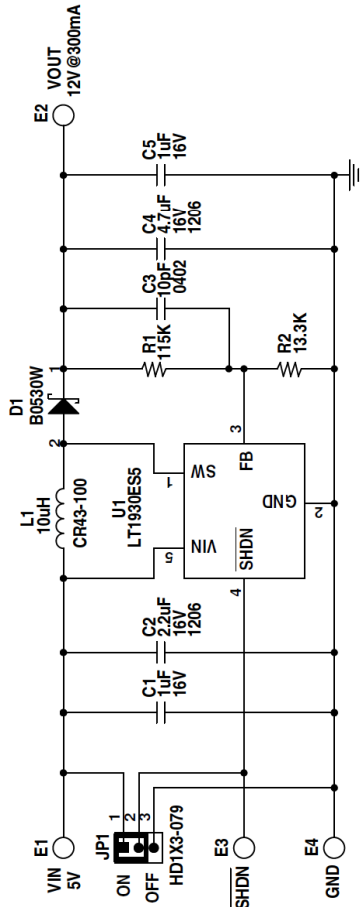

Figure 4. Proper Input/Output Ripple Measurement Technique

### REVISION HISTORY

ECO	REV	DESCRIPTION	APPROVED	DATE
1	1	PRODUCTION	JESUS R.	01-28-10



### BOOST

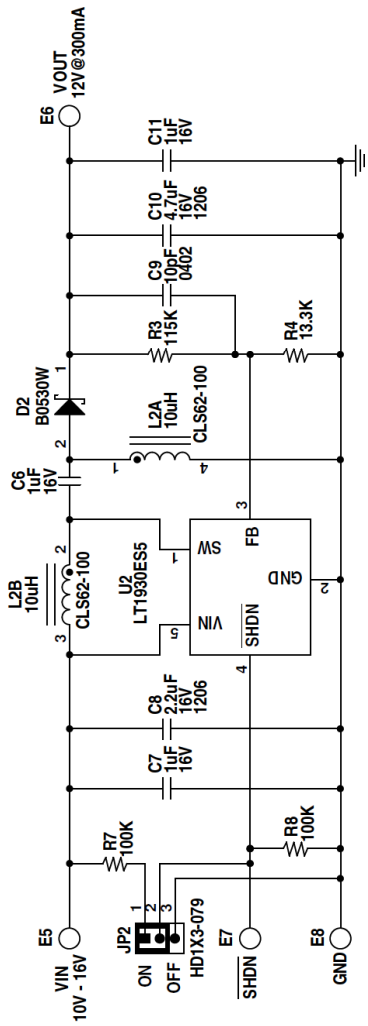

### SEPIC

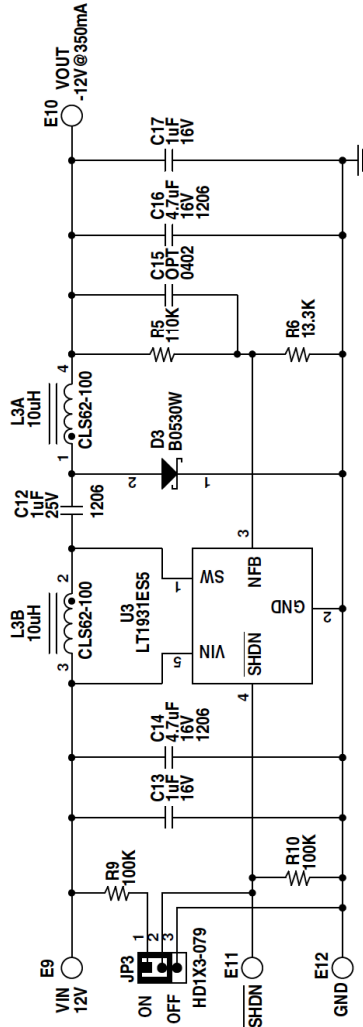

### INVERTER

### CUSTOMER NOTICE

LINEAR TECHNOLOGY HAS MADE A BEST EFFORT TO DESIGN A CIRCUIT THAT MEETS CUSTOMER-SUPPLIED SPECIFICATIONS; HOWEVER, IT REMAINS THE CUSTOMER'S RESPONSIBILITY TO VERIFY PROPER AND RELIABLE OPERATION IN THE ACTUAL APPLICATION. COMPONENT SUBSTITUTION AND PRINTED CIRCUIT BOARD LAYOUT MAY SIGNIFICANTLY AFFECT CIRCUIT PERFORMANCE OR RELIABILITY. CONTACT LINEAR TECHNOLOGY APPLICATIONS ENGINEERING FOR ASSISTANCE.

### NOTES: UNLESS OTHERWISE SPECIFIED

- ALL RESISTORS ARE IN OHMS, 0402.
- ALL CAPACITORS ARE IN MICROFARADS, 0805.
- INSTALL SHUNTS AS SHOWN.



1630 McCarthy Blvd.  
Milpitas, CA 95035  
Phone: (408)432-1900 www.linear.com  
Fax: (408)434-0507  
LTC Confidential-For Customer Use Only

TITLE: SCHEMATIC

1.2MHz, SOT-23 DC/DC CONVERTER

SIZE	IC NO.	REV.
N/A	LT1930ES5 - LT1931ES5	1

DATE: Thursday, January 28, 2010

SCALE = NONE

SHEET 1 OF 1

## X-ON Electronics

Largest Supplier of Electrical and Electronic Components

*Click to view similar products for [Power Management IC Development Tools](#) category:*

*Click to view products by [Analog Devices](#) manufacturer:*

Other Similar products are found below :

[EVAL-ADM1168LQEBZ](#) [EVB-EP5348UI](#) [MIC23451-AAAYFL EV](#) [MIC5281YMME EV](#) [DA9063-EVAL](#) [ADP122-3.3-EVALZ](#) [ADP130-0.8-EVALZ](#) [ADP130-1.2-EVALZ](#) [ADP130-1.5-EVALZ](#) [ADP130-1.8-EVALZ](#) [ADP1714-3.3-EVALZ](#) [ADP1716-2.5-EVALZ](#) [ADP1740-1.5-EVALZ](#) [ADP1752-1.5-EVALZ](#) [ADP1828LC-EVALZ](#) [ADP1870-0.3-EVALZ](#) [ADP1871-0.6-EVALZ](#) [ADP1873-0.6-EVALZ](#) [ADP1874-0.3-EVALZ](#) [ADP1882-1.0-EVALZ](#) [ADP199CB-EVALZ](#) [ADP2102-1.25-EVALZ](#) [ADP2102-1.875EVALZ](#) [ADP2102-1.8-EVALZ](#) [ADP2102-2-EVALZ](#) [ADP2102-3-EVALZ](#) [ADP2102-4-EVALZ](#) [ADP2106-1.8-EVALZ](#) [ADP2147CB-110EVALZ](#) [AS3606-DB](#) [BQ24010EVM](#) [BQ24075TEVM](#) [BQ24155EVM](#) [BQ24157EVM-697](#) [BQ24160EVM-742](#) [BQ24296MEVM-655](#) [BQ25010EVM](#) [BQ3055EVM](#) [NCV891330PD50GEVB](#) [ISLUSBI2CKIT1Z](#) [LM2744EVAL](#) [LM2854EVAL](#) [LM3658SD-AEV/NOPB](#) [LM3658SDEV/NOPB](#) [LM3691TL-1.8EV/NOPB](#) [LM4510SDEV/NOPB](#) [LM5033SD-EVAL](#) [LP38512TS-1.8EV](#) [EVAL-ADM1186-1MBZ](#) [EVAL-ADM1186-2MBZ](#)