

DESCRIPTION

Demonstration circuit 442 is an isolated input to high current output converter featuring the LT[®]1950 switching controller. The DC442 converts isolated 36V to 72V input to 3.3V output and provides over 25A of output current. The converter operates at 230kHz with high efficiency of 92%. The DC442 can be easily modified to generate output voltages in the range from 2.5V to 24V. The output currents are limited by total output power to 200W.

Demonstration circuit 442 can generate output currents as high as 60A with some modifications. The output voltage can also be changed to any value between 2.5V and 24V by changing the MOSFETs, power transformer, output inductor and output capacitors. Please consult LTC factory for details.

The DC442 circuit features soft-start which prevents output voltage overshoot on startup or when recovering from overload condition.

DC442 has a precise over-current protection circuit that allows for continuous operation under short circuit conditions. The low power dissipation under short circuit conditions insures high reliability even during short circuits.

The DC442 can be synchronized to an external clock of up to 350kHz. Please refer to the LT1950 data sheet for design details and applications information.

Design files for this circuit board are available. Call the LTC factory.

LT is a Registered trademark of Linear Technology Corporation

Table 1. Performance Summary

PARAMETER	CONDITION	VALUE
Minimum Input Voltage		32V
Maximum Input Voltage		100V
V _{OUT}	V _{IN} = 36V to 72V, I _{OUT} = 0A to 25A	3.3V ±3%
Typical Output Ripple V _{OUT}	V _{IN} = 36V to 72V, I _{OUT} = 0A to 25A	50mV _{P-P}
Nominal Switching Frequency		230kHz

QUICK START PROCEDURE

Demonstration circuit 442 is easy to set up to evaluate the performance of the LT1950. Refer to Figure 1 for proper measurement equipment setup and follow the procedure below:

NOTE: When measuring the input or output voltage ripple, care must be taken to avoid a long ground lead on the oscilloscope probe. Measure the input or output voltage ripple by touching the probe tip directly across the Vin or Vout and GND terminals. See Figure 2 for proper scope probe technique.

1. With power off, connect the input power supply to Vin and GND. Make sure that the input power supply

has sufficient current rating at minimum input voltage for the required output load.

2. Turn on the power at the input.

NOTE: Make sure that the input voltage does not exceed 100V.

3. Check for the proper output voltage.
V_{out} = 3.3V.

If there is no output, temporarily disconnect the load to make sure that the load is not set too high.

4. Once the proper output voltage is established, adjust the load within the operating range and ob-

QUICK START GUIDE FOR DEMONSTRATION CIRCUIT 442

36V-72VIN TO 3.3V, 25A ISOLATED TELECOM DC/DC CONVERTER

serve the output voltage regulation, ripple voltage, efficiency and other parameters.

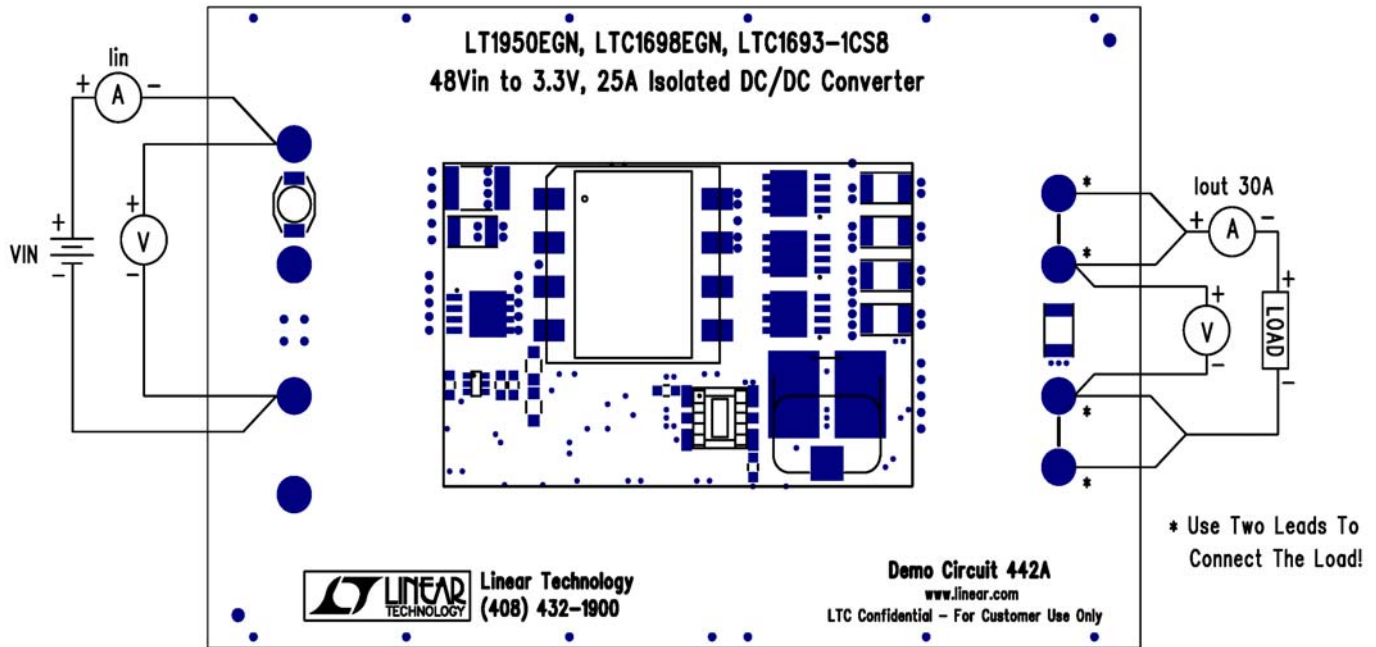

Figure 1. Proper Measurement Equipment Setup

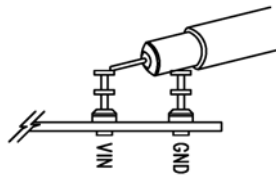

Figure 2. Scope Probe Placement for Measuring Input or Output Ripple

EXTERNAL CLOCK CONNECTION

1. To use external clock source, turn the input power source off.
2. Install 100 ohm R51 resistor. Remove R52 and replace it with 100pF ceramic capacitor. The R51 with 100pF capacitor will filter any noise that may appear on the Ext. Sync input.
3. Set the clock source pulse amplitude to 5V and set the frequency between 250kHz and 350kHz.
4. Turn the clock source off.
5. Connect the clock source (pulse generator with TTL output) to the Ext. Sync input.
6. Apply input power and observe the switching frequency of 230kHz.
7. Turn the clock source ON and observe the switching frequency go up to the switching frequency of the external clock.

USING MOSFET BUFFERS

The optional MOSFET buffers Q20, Q21 and Q22 can improve the efficiency if MOSFETs with high Qg are used or if more MOSFETs are added. By default, the MOSFET buffers are enabled. To test the performance without the buffers, perform the following steps.

1. Turn the power off.
2. Short out the base-emitter resistor of the buffer to be disabled (R16, R17 or R53).
3. Turn the power on.
4. Measure the efficiency.

QUICK START GUIDE FOR DEMONSTRATION CIRCUIT 442

36V-72VIN TO 3.3V, 25A ISOLATED TELECOM DC/DC CONVERTER

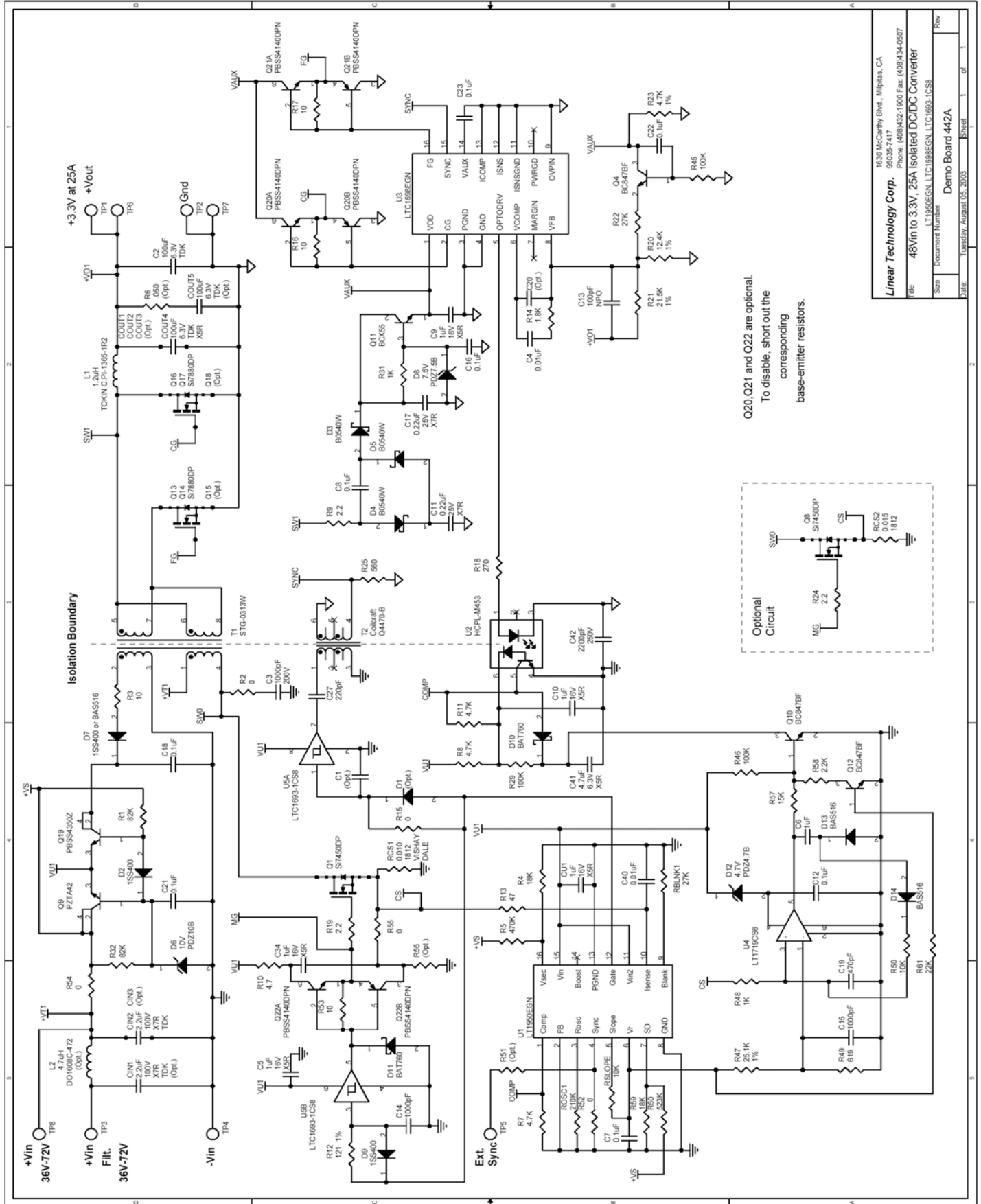

Linear Technology Corp.
 1630 McCarty Blvd., Milpitas, CA
 95035-7417
 Phone: (408)432-1600 Fax: (408)434-0507
 File: 48Vin to 3.3V, 25A Isolated DC/DC Converter
 LTC1696EGN, LTC1696EGN, LTC1693-1CS8
 Size: Document Number
 Demo Board 442A
 Date: Thursday, August 05, 2003 Sheet 1 of 1
 Rev

Q20, Q21 and Q22 are optional.
 To disable, short out the
 corresponding
 base-emitter resistors.

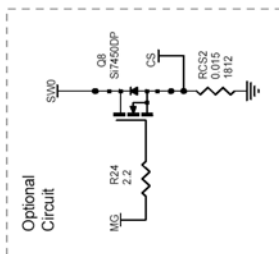

X-ON Electronics

Largest Supplier of Electrical and Electronic Components

Click to view similar products for [Power Management IC Development Tools](#) category:

Click to view products by [Analog Devices](#) manufacturer:

Other Similar products are found below :

[EVAL-ADM1168LQEBZ](#) [EVB-EP5348UI](#) [MIC23451-AAAYFL EV](#) [MIC5281YMME EV](#) [DA9063-EVAL](#) [ADP122-3.3-EVALZ](#) [ADP130-0.8-EVALZ](#) [ADP130-1.2-EVALZ](#) [ADP130-1.5-EVALZ](#) [ADP130-1.8-EVALZ](#) [ADP1714-3.3-EVALZ](#) [ADP1716-2.5-EVALZ](#) [ADP1740-1.5-EVALZ](#) [ADP1752-1.5-EVALZ](#) [ADP1828LC-EVALZ](#) [ADP1870-0.3-EVALZ](#) [ADP1871-0.6-EVALZ](#) [ADP1873-0.6-EVALZ](#) [ADP1874-0.3-EVALZ](#) [ADP1882-1.0-EVALZ](#) [ADP199CB-EVALZ](#) [ADP2102-1.25-EVALZ](#) [ADP2102-1.875EVALZ](#) [ADP2102-1.8-EVALZ](#) [ADP2102-2-EVALZ](#) [ADP2102-3-EVALZ](#) [ADP2102-4-EVALZ](#) [ADP2106-1.8-EVALZ](#) [ADP2147CB-110EVALZ](#) [AS3606-DB](#) [BQ24010EVM](#) [BQ24075TEVM](#) [BQ24155EVM](#) [BQ24157EVM-697](#) [BQ24160EVM-742](#) [BQ24296MEVM-655](#) [BQ25010EVM](#) [BQ3055EVM](#) [NCV891330PD50GEVB](#) [ISLUSBI2CKIT1Z](#) [LM2744EVAL](#) [LM2854EVAL](#) [LM3658SD-AEV/NOPB](#) [LM3658SDEV/NOPB](#) [LM3691TL-1.8EV/NOPB](#) [LM4510SDEV/NOPB](#) [LM5033SD-EVAL](#) [LP38512TS-1.8EV](#) [EVAL-ADM1186-1MBZ](#) [EVAL-ADM1186-2MBZ](#)