

## DESCRIPTION

Demonstration circuit 463 is a step-down (buck) regulator and a Low Drop Out (LDO) regulator using the LTC3700 in the 10-lead MSOP package. The buck regulator is capable of providing 1A at an output voltage of 3.3V from an input supply of 5V to 9V. The LDO can be powered from either the buck regulator output or a separated DC input, and produces an output up to 2.5V at 150mA. The combination of a buck regulator and a LDO, and the use of surface mount components result in a highly efficient application circuit in a very small board

space. The demo circuit highlights the capabilities of the LTC3700. A constant operating frequency of 550kHz makes the LTC3700 attractive for noise-sensitive applications while allowing for smaller external components such as output filter inductor and capacitor. In addition, high efficiency operation over a wide load current range makes the LTC3700 ideal for battery-powered applications.

**Design files for this circuit board are available. Call the LTC factory.**

**Table 1. Performance Summary**

PARAMETER	CONDITION	VALUE
Input Voltage Range of Buck regulator		5V to 9V
Input Voltage Range of LDO		3.3V to 5V
$V_{OUT1}$	$V_{IN} = 5V \text{ to } 9V, I_{OUT1} = 0A \text{ to } 1A$	$3.3V \pm 3\%$
$V_{OUT2}$	$V_{IN} = 3.3V \text{ to } 5V, I_{OUT1} = 0A \text{ to } 150mA$	$2.5V \pm 4\%$
Typical Output Ripple $V_{OUT1}$	$V_{IN} = 5V, I_{OUT1} = 1A$	$30mV_{p-p}$
Typical Output Ripple $V_{OUT2}$	$V_{IN} = 3.3V, I_{OUT2} = 150mA$	$5mV_{p-p}$
Nominal Switching Frequency	Buck Regulator	550kHz

## QUICK START PROCEDURE

Demonstration circuit 463 is easy to set up to evaluate the performance of the LTC3700. Refer to Figure 1 for proper measurement equipment setup and follow the procedure below:

**NOTE:** When measuring the input or output voltage ripple, care must be taken to avoid a long ground lead on the oscilloscope probe. Measure the input or output voltage ripple by touching the probe tip directly across the input or output and ground terminals. See Figure 2 for proper scope probe technique.

1. Connect a 5V to 9V power source to the Vin1 and GND terminals.

2. To operate the LDO circuit with a separate, second input, set JP1 to the Vin2 position. Connect a second 3.3V to 5V power source to the Vin2 and GND terminals.
3. Connect the loads.
4. For single source operation, set the input source selector Jumper JP1 to Vout1 position. Remove the connection of power source Vin2. The LDO will be powered from Vout1.

# QUICK START GUIDE FOR DEMONSTRATION CIRCUIT 463

## STEP-DOWN REGULATOR WITH LDO

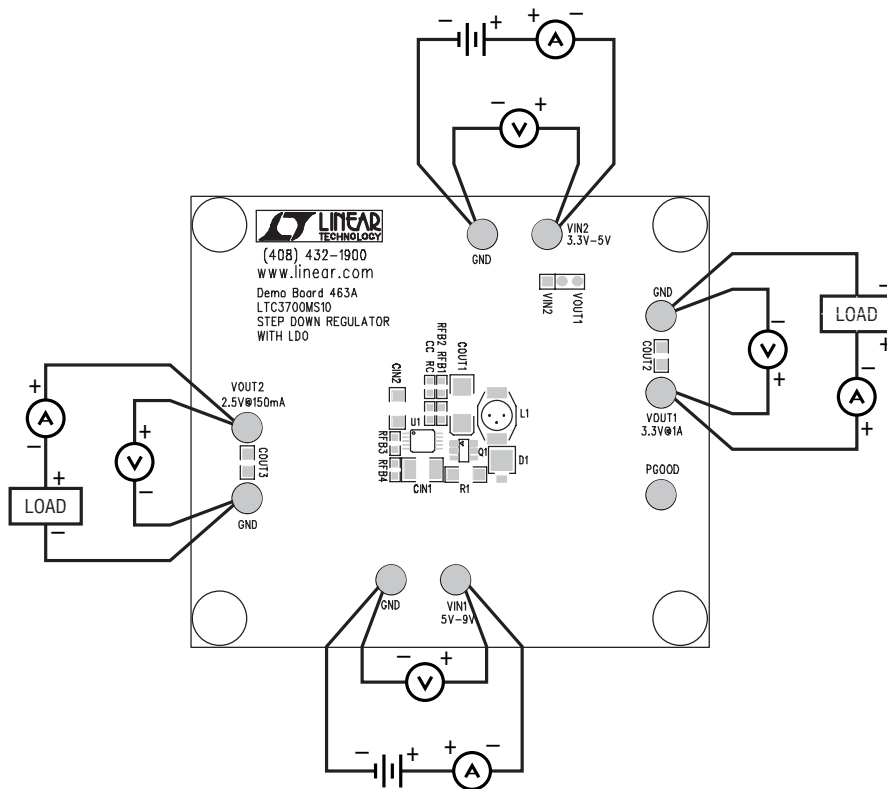

Figure 1. Proper Measurement Equipment Setup

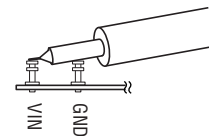

Figure 2. Measuring Input or Output Ripple

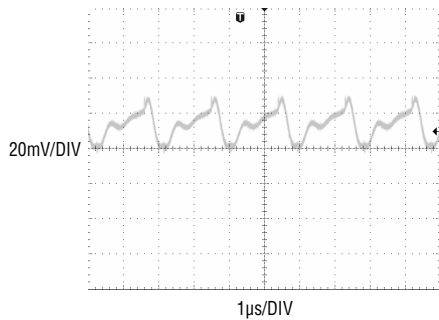

Figure 3. 3.3V Buck Output Ripple  
( $V_{IN} = 5V$ ,  $I_{OUT} = 1A$ )

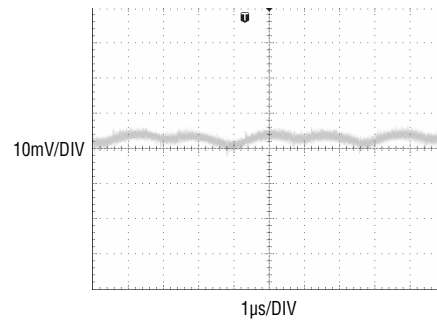
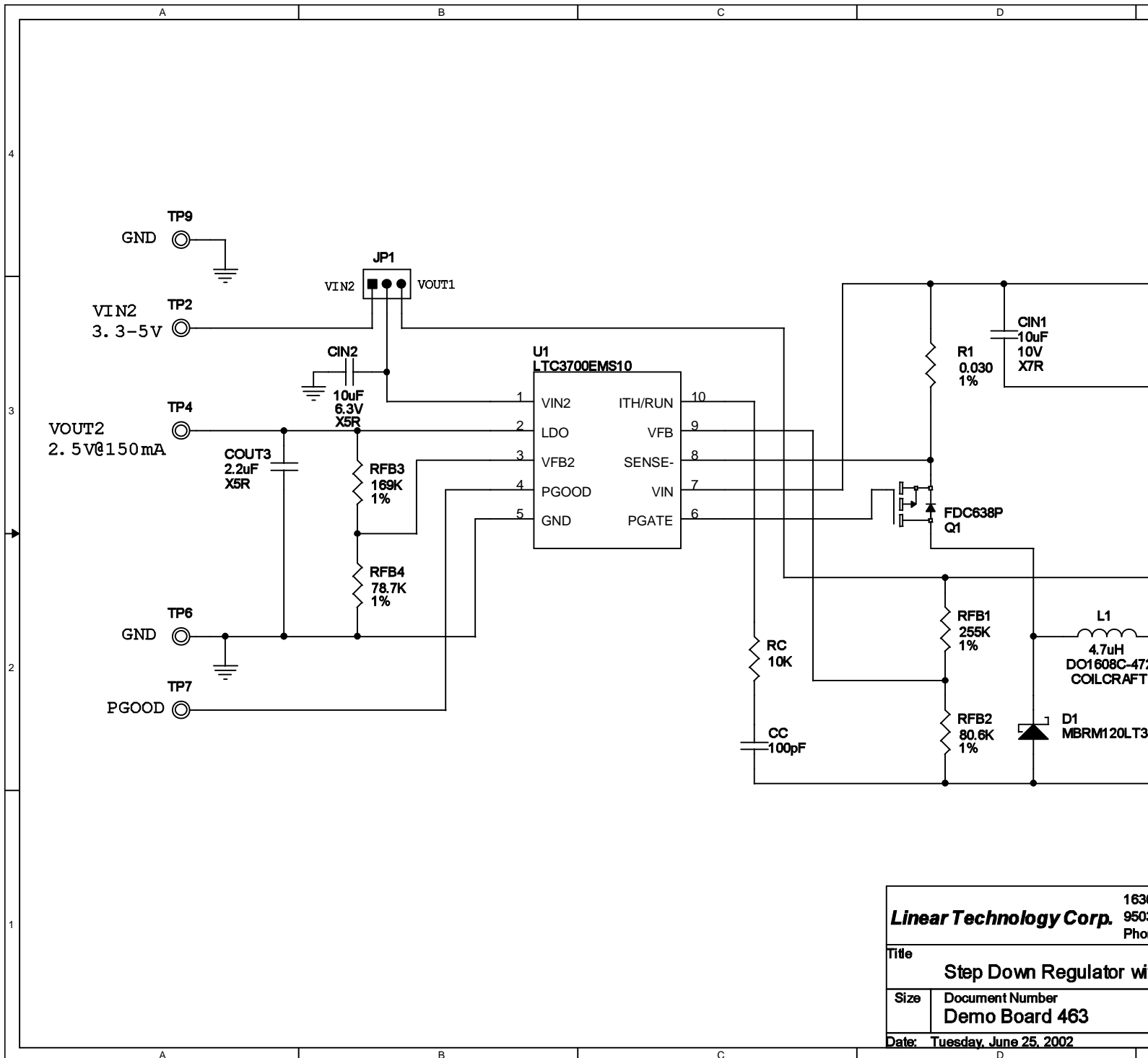

Figure 4. 2.5V LDO Output Ripple  
( $V_{IN} = 3.3V$ ,  $I_{OUT} = 150mA$ )



<b>Linear Technology Corp.</b>		1630
Title		9500
Step Down Regulator with		Pho
Size	Document Number	
	Demo Board 463	
Date: Tuesday, June 25, 2002		

## X-ON Electronics

Largest Supplier of Electrical and Electronic Components

*Click to view similar products for [Power Management IC Development Tools](#) category:*

*Click to view products by [Analog Devices](#) manufacturer:*

Other Similar products are found below :

[EVAL-ADM1168LQEBZ](#) [EVB-EP5348UI](#) [MIC23451-AAAYFL EV](#) [MIC5281YMME EV](#) [DA9063-EVAL](#) [ADP122-3.3-EVALZ](#) [ADP130-0.8-EVALZ](#) [ADP130-1.2-EVALZ](#) [ADP130-1.5-EVALZ](#) [ADP130-1.8-EVALZ](#) [ADP1714-3.3-EVALZ](#) [ADP1716-2.5-EVALZ](#) [ADP1740-1.5-EVALZ](#) [ADP1752-1.5-EVALZ](#) [ADP1828LC-EVALZ](#) [ADP1870-0.3-EVALZ](#) [ADP1871-0.6-EVALZ](#) [ADP1873-0.6-EVALZ](#) [ADP1874-0.3-EVALZ](#) [ADP1882-1.0-EVALZ](#) [ADP199CB-EVALZ](#) [ADP2102-1.25-EVALZ](#) [ADP2102-1.875EVALZ](#) [ADP2102-1.8-EVALZ](#) [ADP2102-2-EVALZ](#) [ADP2102-3-EVALZ](#) [ADP2102-4-EVALZ](#) [ADP2106-1.8-EVALZ](#) [ADP2147CB-110EVALZ](#) [AS3606-DB](#) [BQ24010EVM](#) [BQ24075TEVM](#) [BQ24155EVM](#) [BQ24157EVM-697](#) [BQ24160EVM-742](#) [BQ24296MEVM-655](#) [BQ25010EVM](#) [BQ3055EVM](#) [NCV891330PD50GEVB](#) [ISLUSBI2CKIT1Z](#) [LM2744EVAL](#) [LM2854EVAL](#) [LM3658SD-AEV/NOPB](#) [LM3658SDEV/NOPB](#) [LM3691TL-1.8EV/NOPB](#) [LM4510SDEV/NOPB](#) [LM5033SD-EVAL](#) [LP38512TS-1.8EV](#) [EVAL-ADM1186-1MBZ](#) [EVAL-ADM1186-2MBZ](#)