

DESCRIPTION

Demonstration circuit 477 shows how the LT1683 switching regulator greatly reduces conducted and radiated EMI by controlling the voltage and current slew rates of the two output switches. DC477 employs a push-pull topology which is inherently less noisy than most other topologies and the high frequency EMI is reduced by as much as 40dB by slewing the switching currents and voltages. The design is very well suited for noise sensitive systems such as medical instruments, industrial sensing and control, data conversion and wide band communications.

DC477 can be set up to produce an isolated or non-isolated +5Vout at 2A from a 36Vin – 72Vin range. The Board can be modified, by changing the transformer, to produce multiple output voltages less than or greater than the input voltage. DC477 uses potentiometers that set the slew rates of the power switches, allowing the user to observe the benefit of slew rate control, and to examine the tradeoff between noise performance and circuit efficiency.

Design files for this circuit board are available. Call the LTC factory.

QUICK START PROCEDURE

DC477 is easy to set up to evaluate the performance of the LT1683. Refer to Figure 1 for proper measurement equipment setup and follow the procedure below:

1. Connect the 0 – 2A load between the Vout and Gnd terminals on the right hand side of the board.
2. Apply 48V between the Vin and Gnd terminals on the left hand side of the board.
3. To measure the output noise connect one end of a BNC cable to the BNC connector J1. Connect the other end of the BNC cable to an oscilloscope with a 50 Ohm input impedance ... refer to Application Note AN70 for more precise techniques for measuring the output noise.

Notes:

1. The temperatures of MOSFETs Q3 and Q4 should be monitored if potentiometers R6 and R9 are adjusted from their factory settings.
2. The board comes set up for a non-isolated Vout. The board can also be set up for an isolated Vout by making the following changes:

Insert R18, R23

Remove R19, R21, R22, C16

R10 = 3.9k

R14 = 510 ohm

C18 = 1uF

Insert C20

QUICK START GUIDE FOR DEMONSTRATION CIRCUIT 477

LOW NOISE EMI SWITCHING POWER SUPPLY

Demo Board 477 Rev A Component Side
 LT1683EG

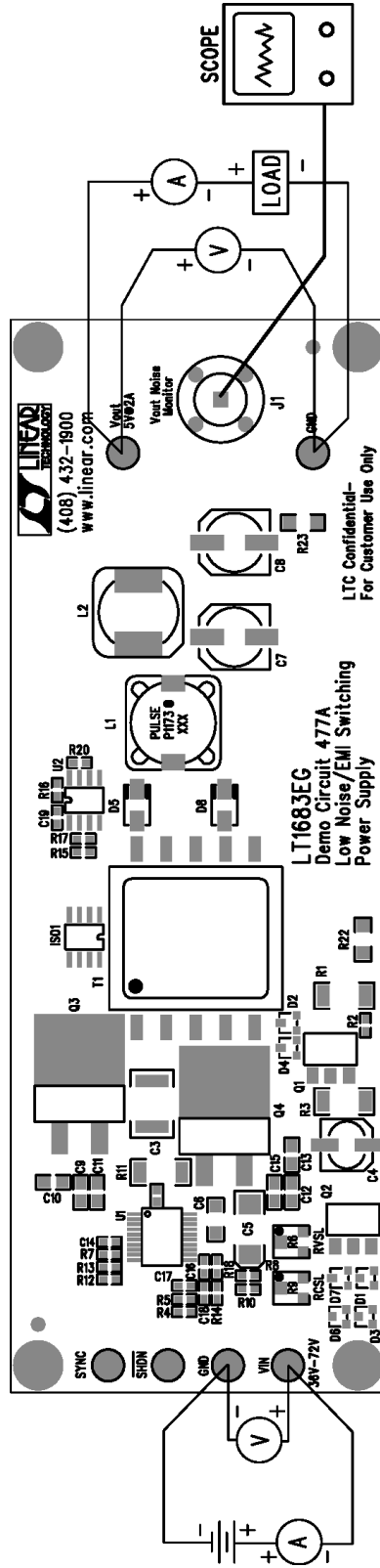
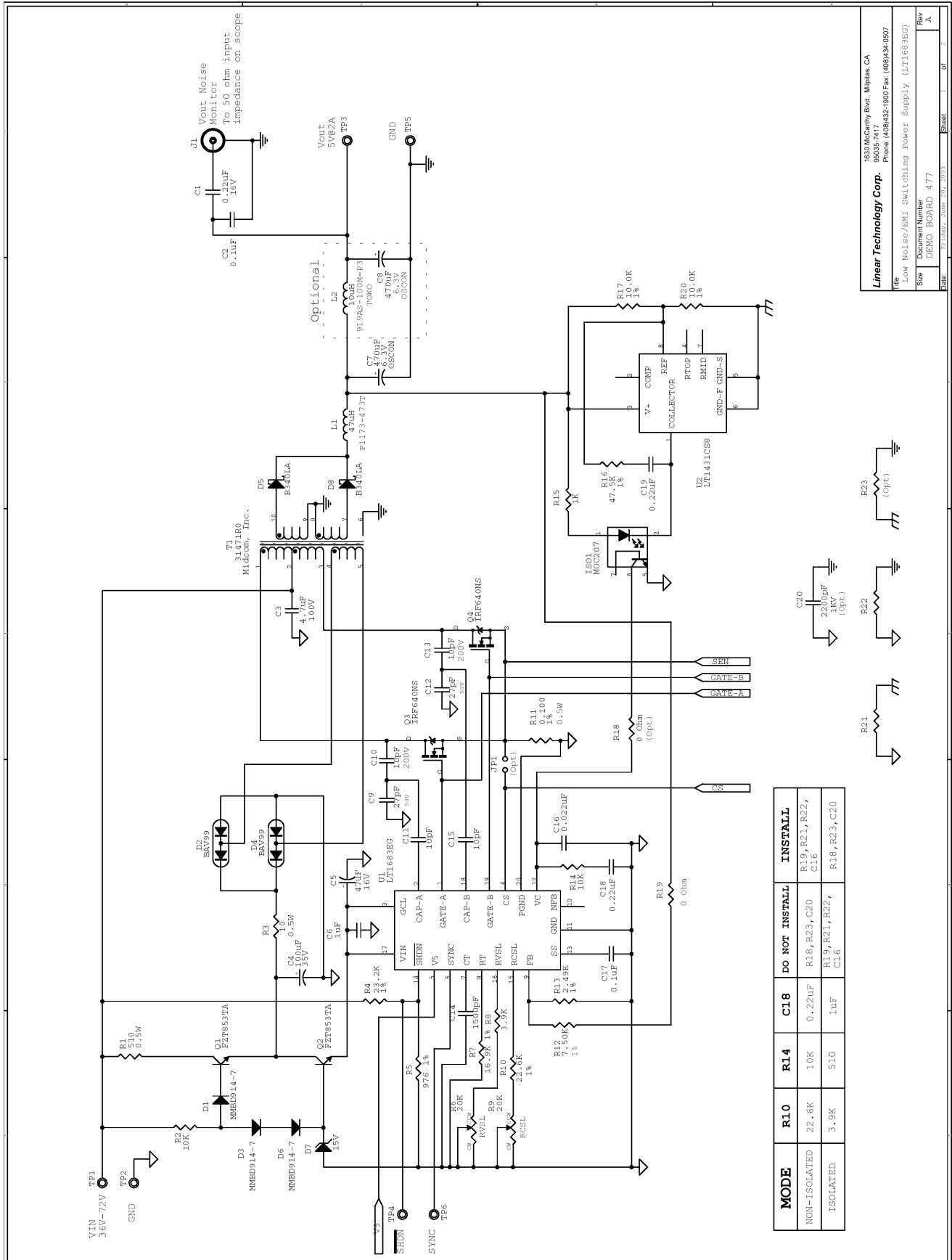

Figure 1. Proper Measurement Equipment Setup

QUICK START GUIDE FOR DEMONSTRATION CIRCUIT 477

LOW NOISE EMI SWITCHING POWER SUPPLY



MODE	R10	R14	C18	DO NOT INSTALL	INSTALL
NON-ISOLATED	22.6K	10K	0.22uF	R18, R23, C20 C16	R19, R21, R22, C16
ISOLATED	3.9K	510	1uF	R19, R21, R22, C16	R18, R23, C20

Linear Technology Corp.
 1820 McCarthy Blvd., Milpitas, CA
 95035-5417
 Phone: (408)432-1900 Fax: (408)434-0507
 Low Noise/EMI Switching Power Supply (LT1693EG)
 Document Number: DENO BOARD 477
 Size: 11.000" x 8.500" x 0.003" Sheet 1 of 2
 Rev: A

QUICK START GUIDE FOR DEMONSTRATION CIRCUIT 477

LOW NOISE \ EMI SWITCHING POWER SUPPLY

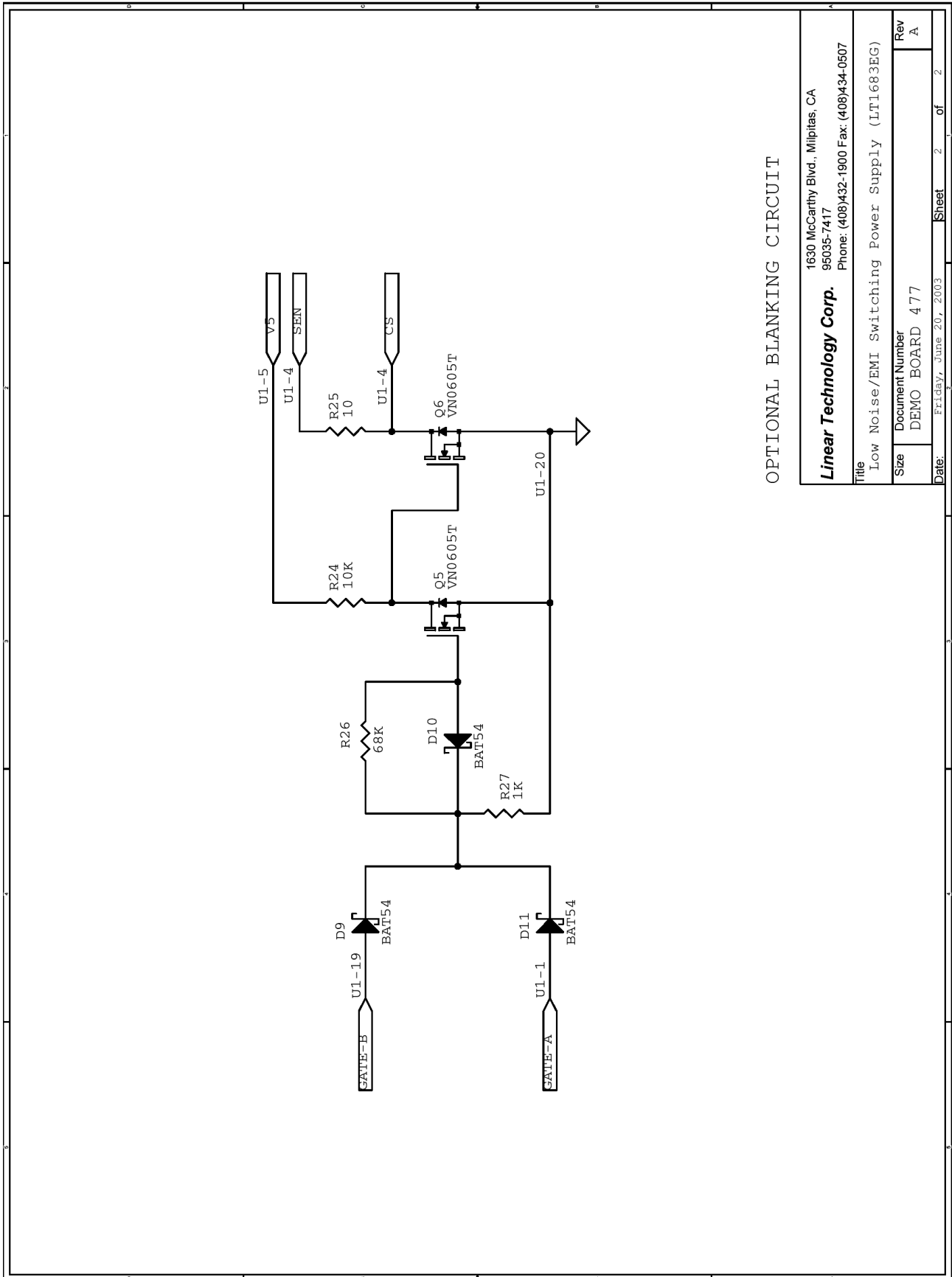

OPTIONAL BLANKING CIRCUIT

Linear Technology Corp.
 1630 McCarthy Blvd., Milpitas, CA
 95035-7417
 Phone: (408)432-1900 Fax: (408)434-0507

Title: Low Noise/EMI Switching Power Supply (LT1683EG)

Size	Document Number	Rev
	DEMO BOARD 477	A

Date: Friday, June 20, 2003 Sheet 2 of 2

QUICK START GUIDE FOR DEMONSTRATION CIRCUIT 477

LOW NOISE \ EMI SWITCHING POWER SUPPLY

Item	Qty	Reference	Part Description	Manufacture / Part #
1	1	C1	Cap., X7R 0.22uF 16V 20%	Taiyo Yuden EMK107BJ224MA
2	2	C2,C17	Cap., X7R 0.1uF 16V 10%	AVX 0603YC104KAT1A
3	1	C3	Cap., Y5U 4.7uF 100V 80%	Marcon THCS60E2A475ZT
4	1	C4	Cap., Alum 100uF 35V 10%	OSCON 35CV100BS
5	1	C5	Cap., POSCAP 47uF 16V 20%	SANYO 16TQC47M
6	1	C6	Cap., X7R 1uF 16V 20%	Taiyo Yuden EMK316BJ105MF
7	2	C7,C8	Cap., 470uF 6.3V 20%	OSCON 6SVP470M
8	2	C12,C9	Cap., NPO 27pF 50V 10%	AVX 08055A270KAT1A
9	2	C10,C13	Cap., NPO 10pF 200V 10%	AVX 08052A100KAT2A
10	2	C11,C15	Cap., NPO 10pF 50V 10%	AVX 08055A100KAT1A
11	1	C14	Cap., X7R 1500pF 25V 10%	AVX 06033C152KAT1A
12	1	C16	Cap., X7R 0.022uF 25V 10%	AVX 06033C223KAT1A
13	2	C18,19	Cap., X7R 0.22uF 10V 10%	AVX 0603ZC224KAT1A
14	0	C20	Cap., X7R 2200pF 1KV 20%	AVX 1206AC222MA11A
15	3	D1,D3,D6	Diode, HI Speed Switching	Diodes Inc. MMBD914-7
16	2	D4,D2	Diode, High Speed Double	PHILIPS BAV99
17	2	D5,D8	Diode Schotkky 40V/3Amp	Diodes Inc. B340LA
18	1	D7	Zener Diode, 15V	Diodes Inc. MMBZ5245B
19	3	D9,D10,D11	Diode SCHOTTKY	Diodes Inc. BAT54-7
20	1	ISO1	I.C., Optoisolator	Fairchild Semi. MOC207
21	0	JP1 (Opt)	Jumper	
22	1	J1	BNC Connector	Connex 112404
23	1	L1	Inductor, 47uH	Pulse Engrng. Inc. P1173-473T
24	1	L2	Inductor, 10uH	TOKO 919AS-100M=P3
25	2	Q1,Q2	XSTR, Sil. Planar NPN	Zetex FZT853TA
26	2	Q4,Q3	Power MOSFET, 200V / 18A	IRF IRF640NS
27	2	Q5,Q6	N-Chan. Mosfet Trans.	Vishay Siliconix VN0605T
28	1	R1	Res., Chip 510 0.5W 5%	KOA, RM73B2H511JTE
29	2	R24,R2	Res., Chip 10K 0.1W 5%	AAC CR16-103JM
30	1	R3	Res., Chip 10 0.5W 5%	AAC CR12-100JM
31	1	R4	Res., Chip 23.2K 0.1W 1%	AAC CR16-2322FM
32	1	R5	Res., Chip 976 0.06W 1%	AAC CR16-9760FM
33	2	R6,R9	Pot. 11 Turns 20K	Bourns 3224W-1-203E
34	1	R7	Res., Chip 16.9K 0.1W 1%	AAC CR16-1692FM
35	1	R8	Res., Chip 3.9K 0.1W 5%	AAC CR16-392JM
36	1	R10	Res., Chip 22.6K 0.1W 1%	AAC CR16-2262FM

X-ON Electronics

Largest Supplier of Electrical and Electronic Components

Click to view similar products for [Power Management IC Development Tools](#) category:

Click to view products by [Analog Devices](#) manufacturer:

Other Similar products are found below :

[EVAL-ADM1168LQEBZ](#) [EVB-EP5348UI](#) [MIC23451-AAAYFL EV](#) [MIC5281YMME EV](#) [DA9063-EVAL](#) [ADP122-3.3-EVALZ](#) [ADP130-0.8-EVALZ](#) [ADP130-1.2-EVALZ](#) [ADP130-1.5-EVALZ](#) [ADP130-1.8-EVALZ](#) [ADP1714-3.3-EVALZ](#) [ADP1716-2.5-EVALZ](#) [ADP1740-1.5-EVALZ](#) [ADP1752-1.5-EVALZ](#) [ADP1828LC-EVALZ](#) [ADP1870-0.3-EVALZ](#) [ADP1871-0.6-EVALZ](#) [ADP1873-0.6-EVALZ](#) [ADP1874-0.3-EVALZ](#) [ADP1882-1.0-EVALZ](#) [ADP199CB-EVALZ](#) [ADP2102-1.25-EVALZ](#) [ADP2102-1.875EVALZ](#) [ADP2102-1.8-EVALZ](#) [ADP2102-2-EVALZ](#) [ADP2102-3-EVALZ](#) [ADP2102-4-EVALZ](#) [ADP2106-1.8-EVALZ](#) [ADP2147CB-110EVALZ](#) [AS3606-DB](#) [BQ24010EVM](#) [BQ24075TEVM](#) [BQ24155EVM](#) [BQ24157EVM-697](#) [BQ24160EVM-742](#) [BQ24296MEVM-655](#) [BQ25010EVM](#) [BQ3055EVM](#) [NCV891330PD50GEVB](#) [ISLUSBI2CKIT1Z](#) [LM2744EVAL](#) [LM2854EVAL](#) [LM3658SD-AEV/NOPB](#) [LM3658SDEV/NOPB](#) [LM3691TL-1.8EV/NOPB](#) [LM4510SDEV/NOPB](#) [LM5033SD-EVAL](#) [LP38512TS-1.8EV](#) [EVAL-ADM1186-1MBZ](#) [EVAL-ADM1186-2MBZ](#)