

DESCRIPTION

Demonstration circuit 495 is a single battery stand-alone battery charge controller with built in charge termination featuring the LTC®4006. The input voltage is 9 to 20V. The charger output voltage is fixed for a 2cell 8.4V Li-ion battery. The maximum charge current is 2A. The board will automatically charge a battery to termination as soon as input power is applied with a battery connected prior to power up. Status LEDs are provided for CHG, ACP, and C/10. An onboard NTC thermistor is provided. Although this charger is not a smart battery charger, a popular smart battery connector is provided that

can be used for data logging with the OPTIONAL DC1223A-B Demo board and software. To be clear, you do NOT need a smart battery to use this board. The optional DC1223A-B SMBUS to USB port adapter and associated software to monitor a smart battery for demonstration purposes only. Contact your LT representative for ordering a DC1223A-B.

Design files for this circuit board are available. Call the LTC factory.

LTC is a registered trademark of Linear Technology Corporation.

Table 1. Performance Summary

PARAMETER	CONDITION	VALUE
Maximum Input Voltage	Limited by input Capacitor Volt Ratings.	20V +/- 10 %
Recommended Minimum Input Voltage	$V_{in} > V_{bat}$ Termination voltage.	9V when using an 8.4V Li-ion battery.
Input Current Limit		2 Amps
Maximum Charge Current	$V_{in} > V_{batmax} > 6V$	2A +/- 5%

QUICK START PROCEDURE

Demonstration circuit 495 is easy to set up to evaluate the performance of the LTC4006. Refer to Figure 1 for proper measurement equipment setup and follow the procedure below:

NOTE: When measuring the input or output voltage ripple, care must be taken to avoid a long ground lead

1. Connect the input power source to DCIN terminals J1 or DCIN and GND using a power supply capable of handling 2.5A of current within a 9 to 20V range. The input supply **MUST** be greater than the full voltage value of the battery to allow a full charge to take place.
2. Connect the load to DCOUT and GND terminals.
3. Plug in s 8.4V Li-ion battery. Industry standard 5 Pin AMP Smart Battery connector is provided as well as generic soldering Test Points for hardwire connections.
4. Turn on the input power supply.
5. Optionally use the provided DC1223A-B demonstration software to control and configure the DC495.

on the oscilloscope probe. Measure the input or output voltage ripple by touching the probe tip directly across the V_{IN} or V_{OUT} and GND terminals. See Figure 2 for proper scope probe technique.

QUICK START GUIDE FOR DEMONSTRATION CIRCUIT 495

2 CELL LI-ION BATTERY CHARGER WITH CHARGE TERMINATION

6. **NOTE:** If the board is allowed to get to warm, the onboard NTC thermistor may trip and momentarily suspend the charge process. This can be confirmed by the fault LED turning on. When the board cools down, charging will resume.

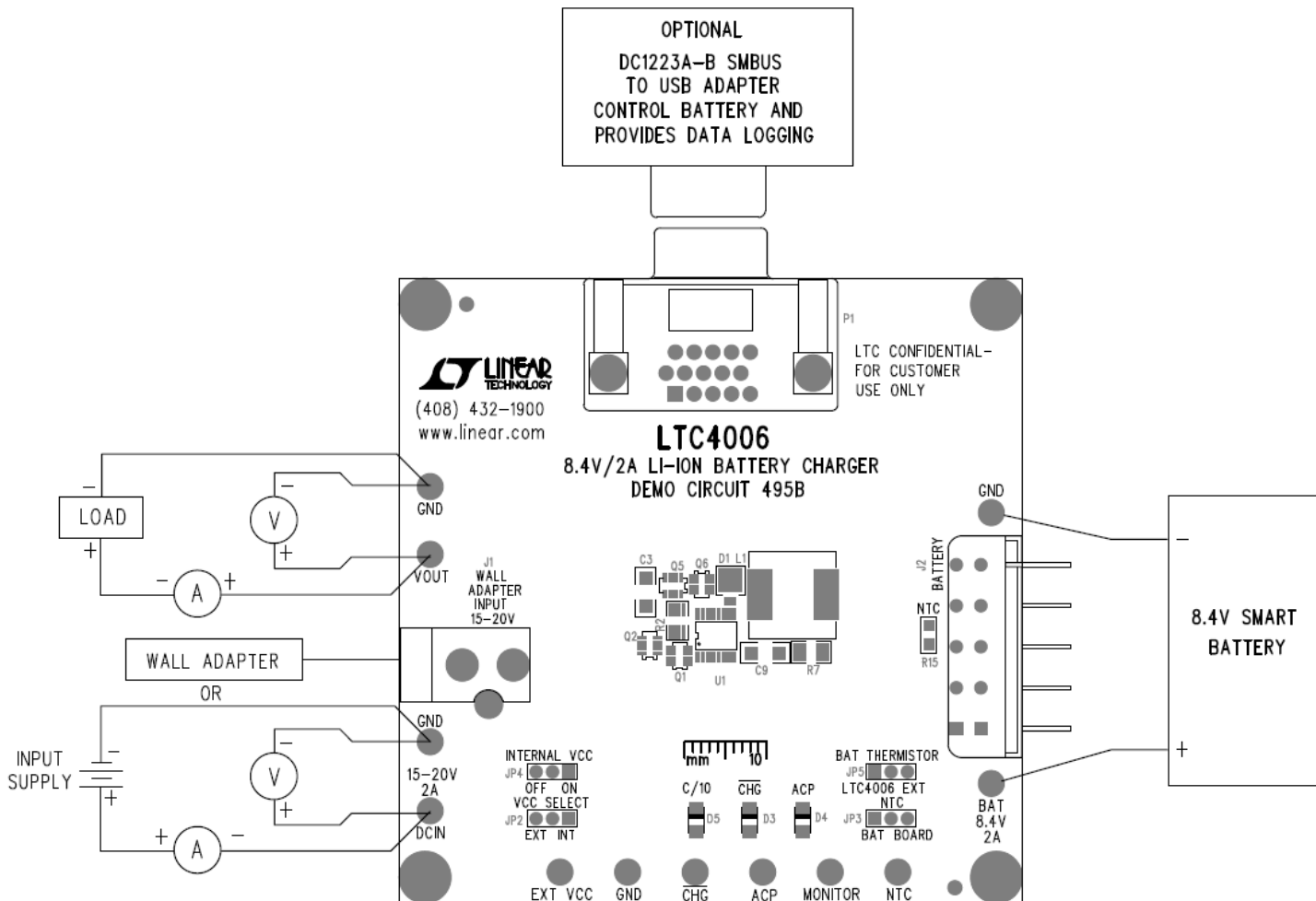

Figure 1: Proper Measurement Equipment Setup

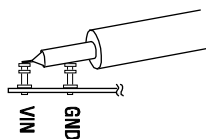
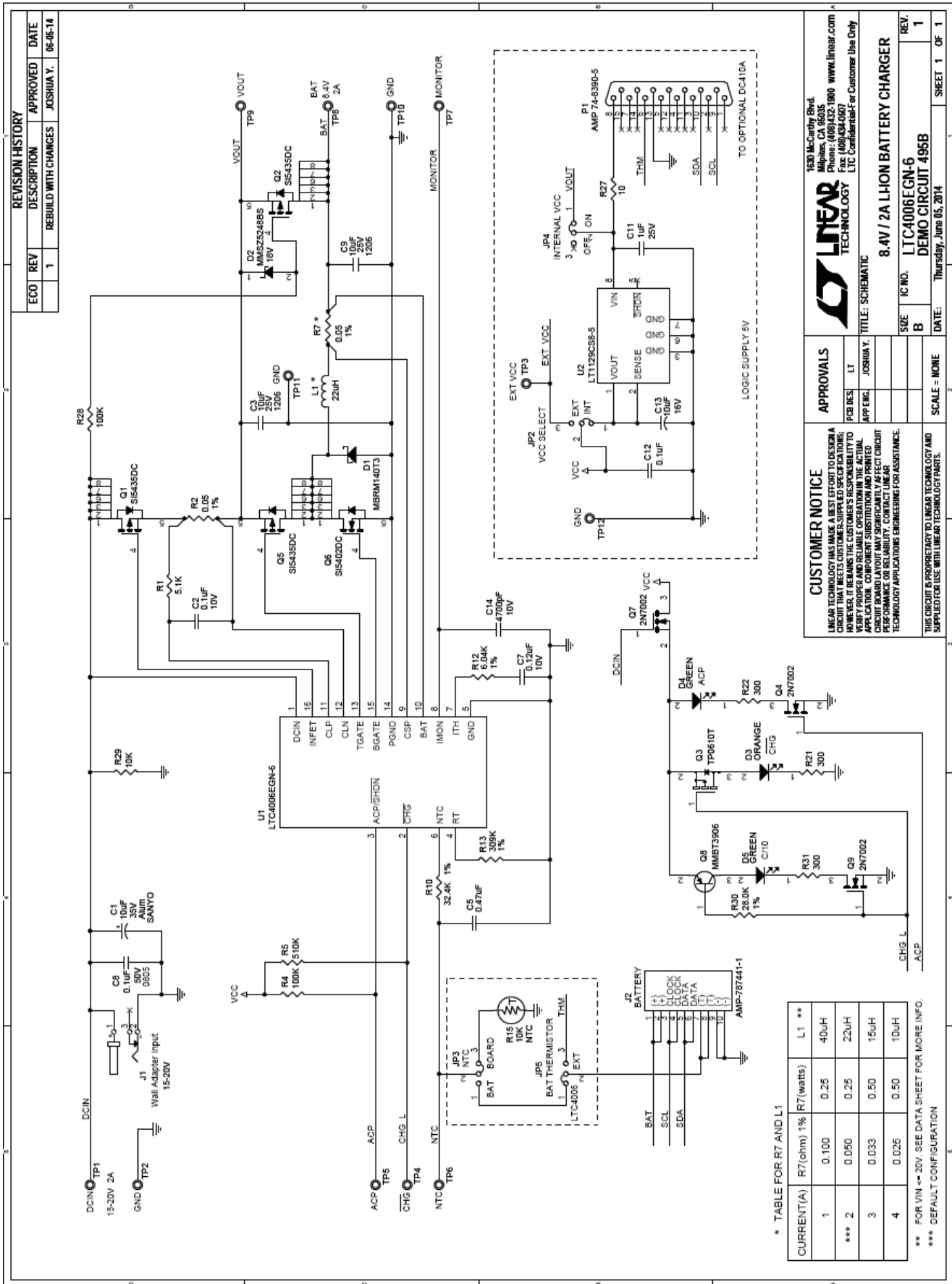

Figure 2: Scope Probe Placement for Measuring Input or Output Ripple

QUICK START GUIDE FOR DEMONSTRATION CIRCUIT 495

2 CELL LI-ION BATTERY CHARGER WITH CHARGE TERMINATION



X-ON Electronics

Largest Supplier of Electrical and Electronic Components

Click to view similar products for [Power Management IC Development Tools](#) category:

Click to view products by [Analog Devices](#) manufacturer:

Other Similar products are found below :

[EVAL-ADM1168LQEBZ](#) [EVB-EP5348UI](#) [MIC23451-AAAYFL EV](#) [MIC5281YMME EV](#) [DA9063-EVAL](#) [ADP122-3.3-EVALZ](#) [ADP130-0.8-EVALZ](#) [ADP130-1.2-EVALZ](#) [ADP130-1.5-EVALZ](#) [ADP130-1.8-EVALZ](#) [ADP1714-3.3-EVALZ](#) [ADP1716-2.5-EVALZ](#) [ADP1740-1.5-EVALZ](#) [ADP1752-1.5-EVALZ](#) [ADP1828LC-EVALZ](#) [ADP1870-0.3-EVALZ](#) [ADP1871-0.6-EVALZ](#) [ADP1873-0.6-EVALZ](#) [ADP1874-0.3-EVALZ](#) [ADP1882-1.0-EVALZ](#) [ADP199CB-EVALZ](#) [ADP2102-1.25-EVALZ](#) [ADP2102-1.875EVALZ](#) [ADP2102-1.8-EVALZ](#) [ADP2102-2-EVALZ](#) [ADP2102-3-EVALZ](#) [ADP2102-4-EVALZ](#) [ADP2106-1.8-EVALZ](#) [ADP2147CB-110EVALZ](#) [AS3606-DB](#) [BQ24010EVM](#) [BQ24075TEVM](#) [BQ24155EVM](#) [BQ24157EVM-697](#) [BQ24160EVM-742](#) [BQ24296MEVM-655](#) [BQ25010EVM](#) [BQ3055EVM](#) [NCV891330PD50GEVB](#) [ISLUSBI2CKIT1Z](#) [LM2744EVAL](#) [LM2854EVAL](#) [LM3658SD-AEV/NOPB](#) [LM3658SDEV/NOPB](#) [LM3691TL-1.8EV/NOPB](#) [LM4510SDEV/NOPB](#) [LM5033SD-EVAL](#) [LP38512TS-1.8EV](#) [EVAL-ADM1186-1MBZ](#) [EVAL-ADM1186-2MBZ](#)