

DESCRIPTION

Demonstration circuit 501 is high power, high voltage, and high efficiency DC/DC buck converter featuring the LTC3703.

This is a general-purpose high voltage DC to DC with an input voltage range of 20V to 72V. The board is optimized for positive 48V input operation with high voltage surges up to 72VDC allowed. The limiting factor is the LTC3703 GN16 package that will not meet UL/CSA/IEC60950 clearance and creepage distance requirements above the SELV 60VDC maximum due to pin spacing. If the user wishes to support higher continuous input voltages or compliance to 60950, the LTC3703 is offered in a G-28 pin package. See Data Sheet. However, for the purposes of evaluation, the board will work reliably up to 72V.

The maximum continuous current in free air is 4A. 6A is permissible with some forced air cooling. The output voltage is programmed with a voltage divider and configured for 12V.

The demonstration circuit comes with jumpers preset to power up in the continuous switching mode. Test points are provided to monitor or control Mode/SYNC, BGRTN and VCC.

Configuration jumpers allow Burst or Continuous Switch mode operation (JP1), to turn the power supply On and OFF (JP2) and Vcc or Boost Bias Supply select (JP3).

The board has been laid out to support up to 12A of DC current buy doubling the MOSFETs and input capacitors along with an inductor with lower DC resistance and higher current ratings. Some forced air cooling will be required.

Special consideration must be given to the inductor chosen. The short circuit current has a very wide tolerance with initial transient spikes that work against the use of a Ferrite based inductor. A powder based magnetic core material is highly recommended. Whatever inductor is chosen, the circuit should be checked for proper short circuit operation by verifying the inductor does not saturate.

The board can also support a boost converter configuration. See schematic.

Design files for this circuit board are available. Call the LTC factory.

Table 1. Performance Summary

PARAMETER	CONDITION/NOTES	VALUE
Maximum Input Voltage	Limited by MOSFET Voltage Ratings.	72V \pm 10 %
Minimum Input Voltage		20V \pm 10 %
Efficiency	Vin = 48V with 4 amp load	93%
	Vin = 24V with 4 amp load	95%
Switching Frequency	User adjustable.	260KHz Nominal
Output Voltage	0 to 6 Amps measured at VOUT and GND terminals.	12V \pm 2 %
Maximum Current Free Air	Limited by temperature rise of inductor.	4A
Maximum Current with Force Air cooling	Accuracy and limit set by Rds-on value of bottom MOSFET. See Datasheet.	6A -0A / +3A

QUICK START GUIDE FOR DEMONSTRATION CIRCUIT 501

Universal High Input Voltage 12V/6A POWER SUPPLY

QUICK START PROCEDURE

Demonstration circuit 501 is easy to set up to evaluate the performance of the LTC3703. Refer to Figure 1 for proper measurement equipment setup and follow the procedure below:

1. Connect a power source to the VIN and GND. The power supply must be capable of at least 120 watts of power at the input voltage you choose provided it is within the Vin range permitted.

2. Connect a load to the VOUT and GND terminals and set it to 0Amps
3. Turn on the input power supply and DC501 should power up.
4. Adjust load as required for evaluation.

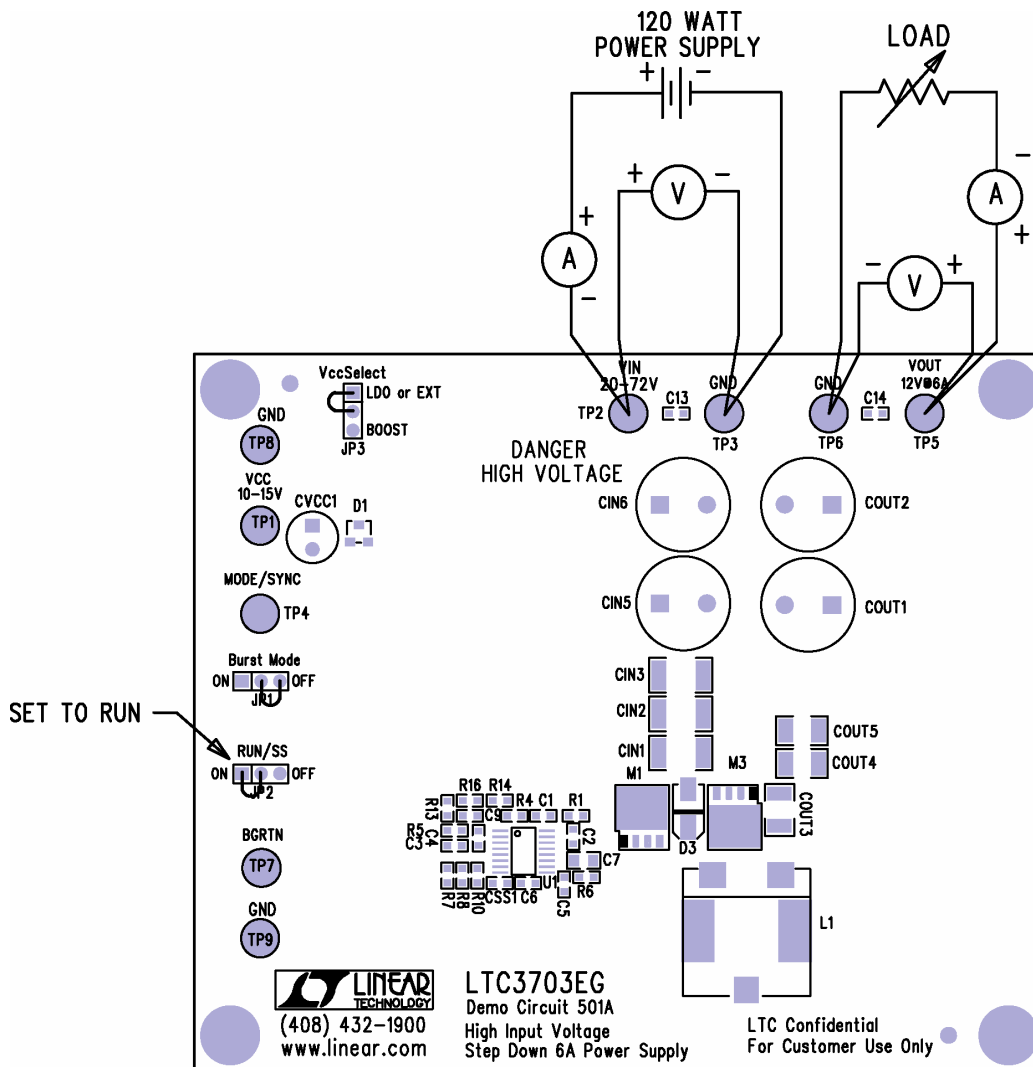
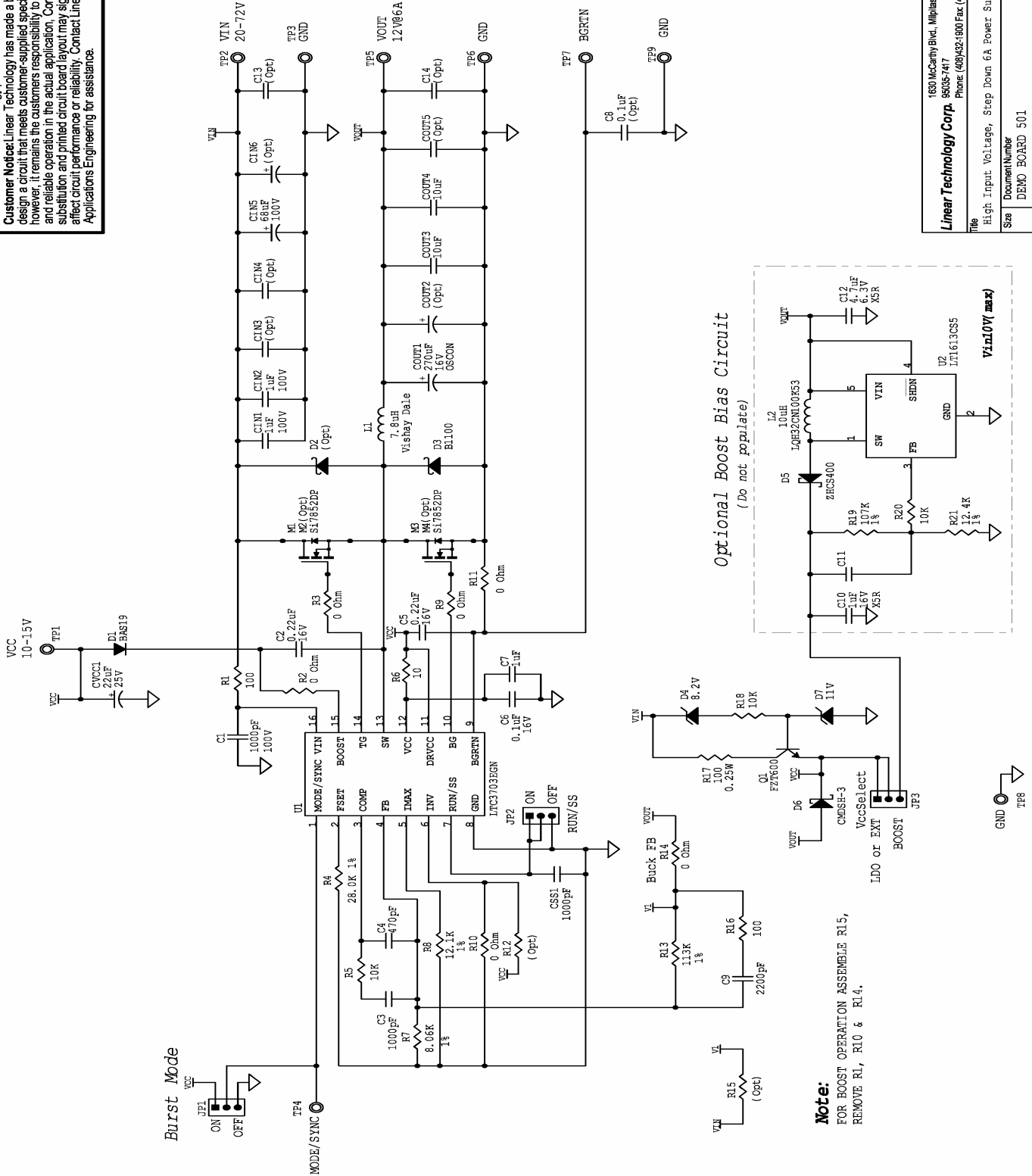

Figure 1. Proper Measurement Equipment Setup

QUICK START GUIDE FOR DEMONSTRATION CIRCUIT 501

Universal High Input Voltage 12V/6A POWER SUPPLY

This circuit is proprietary to Linear Technology and supplied for use with Linear Technology parts.
Customer Notice: Linear Technology has made a best effort to design a circuit that meets customer-supplied specifications; however, it remains the customer's responsibility to verify proper and reliable operation in the actual application. Component substitution and printed circuit board layout may significantly affect circuit performance or reliability. Contact Linear Applications Engineering for assistance.



Linear Technology Corp.
 1630 McCarty Blvd, Milpitas, CA
 95035-7417
 Phone: (408) 321-9800 Fax: (408) 354-6507

Title: High Input Voltage, Step Down 6A Power Supply
 Document Number: DEMO BOARD 501
 Rev: A
 Date: Wednesday, March 31, 2004

X-ON Electronics

Largest Supplier of Electrical and Electronic Components

Click to view similar products for [Power Management IC Development Tools](#) category:

Click to view products by [Analog Devices](#) manufacturer:

Other Similar products are found below :

[EVAL-ADM1168LQEBZ](#) [EVB-EP5348UI](#) [MIC23451-AAAYFL EV](#) [MIC5281YMME EV](#) [DA9063-EVAL](#) [ADP122-3.3-EVALZ](#) [ADP130-0.8-EVALZ](#) [ADP130-1.2-EVALZ](#) [ADP130-1.5-EVALZ](#) [ADP130-1.8-EVALZ](#) [ADP1714-3.3-EVALZ](#) [ADP1716-2.5-EVALZ](#) [ADP1740-1.5-EVALZ](#) [ADP1752-1.5-EVALZ](#) [ADP1828LC-EVALZ](#) [ADP1870-0.3-EVALZ](#) [ADP1871-0.6-EVALZ](#) [ADP1873-0.6-EVALZ](#) [ADP1874-0.3-EVALZ](#) [ADP1882-1.0-EVALZ](#) [ADP199CB-EVALZ](#) [ADP2102-1.25-EVALZ](#) [ADP2102-1.875EVALZ](#) [ADP2102-1.8-EVALZ](#) [ADP2102-2-EVALZ](#) [ADP2102-3-EVALZ](#) [ADP2102-4-EVALZ](#) [ADP2106-1.8-EVALZ](#) [ADP2147CB-110EVALZ](#) [AS3606-DB](#) [BQ24010EVM](#) [BQ24075TEVM](#) [BQ24155EVM](#) [BQ24157EVM-697](#) [BQ24160EVM-742](#) [BQ24296MEVM-655](#) [BQ25010EVM](#) [BQ3055EVM](#) [NCV891330PD50GEVB](#) [ISLUSBI2CKIT1Z](#) [LM2744EVAL](#) [LM2854EVAL](#) [LM3658SD-AEV/NOPB](#) [LM3658SDEV/NOPB](#) [LM3691TL-1.8EV/NOPB](#) [LM4510SDEV/NOPB](#) [LM5033SD-EVAL](#) [LP38512TS-1.8EV](#) [EVAL-ADM1186-1MBZ](#) [EVAL-ADM1186-2MBZ](#)