

DESCRIPTION

Demonstration circuit 506A is a two-phase, step down charge pump DC/DC converter featuring the LTC3251EMSE. It produces regulated 1.5V output voltage at up to 500mA of output current from 3.2V to 5.5V input. A unique two phase, spread spectrum architecture of the LTC3251 provides highly efficient and low noise operation. The burst and super-burst operating modes also reduce operating current at light load conditions. The circuit has

a low external parts count and requires only four small surface mount capacitors. DC 506 demonstrates appropriate layout techniques for the LTC3251 Inductorless DC-DC converter. This power supply circuit is ideally suited for space-constrained battery-powered applications that require small size and low operating current.

Design files for this circuit board are available. Call the LTC factory.

QUICK START PROCEDURE

Demonstration circuit DC506 is easy to set up to evaluate the performance of the LTC3251. Refer to Figure 1 for proper measurement equipment setup and follow the procedure below:

NOTE:When measuring the input or output voltage ripple, care must be taken to avoid a long ground lead on the oscilloscope probe. Measure the input or output voltage ripple by touching the probe tip directly across the VIN or VOUT and GND terminals. See Figure 2 for proper scope probe technique.

1. With power off, connect input power source to VIN and GND terminals. Input voltage range is limited to between 3.2V and 5.5V.
2. Place operation mode selector jumper JP1 in the GND position, JP2 in the VIN position for Burst Mode operation.
3. Connect load between the VOUT and GND terminals.
4. Turn on the power at the input.

NOTE:Make sure that the input voltage does not exceed 5.5V.

5. Check for the proper output voltages. VOUT = 1.5V.

If there is no output, temporarily disconnect the load to make sure that the load is not set too high.

6. Once the proper output voltages are established, adjust the loads up to 500mA and observe the output voltage regulation, input and output ripple voltage, efficiency and other parameters.

NOTE: IOUT derates linearly to 200mA for VIN less than 3.5V.

7. For continuous mode operation, set operation mode selector jumper JP1 in the VIN position, JP2 in the GND position. Please refer Table 1 for other modes of operation.

Table 1. Modes of Operation:

JP1	JP2	MODE
GND	GND	SHUTDOWN
GND	VIN	BURST
VIN	GND	CONTINUOUS
VIN	VIN	SUPER BURST

QUICK START GUIDE FOR DEMONSTRATION CIRCUIT 506

500mA SPREAD-SPECTRUM, LOW NOISE, INDUCTORLESS STEP DOWN DC/DC CONVERTER

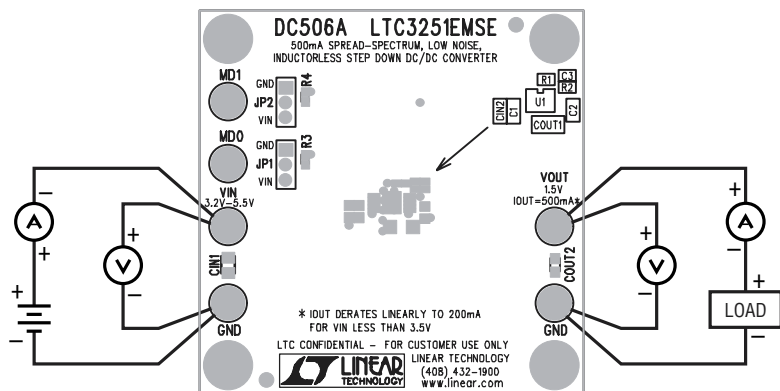

Figure 1. Proper Measurement Equipment Setup

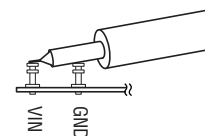

Figure 2. Scope Probe Placement for Measuring Input or Output Ripple

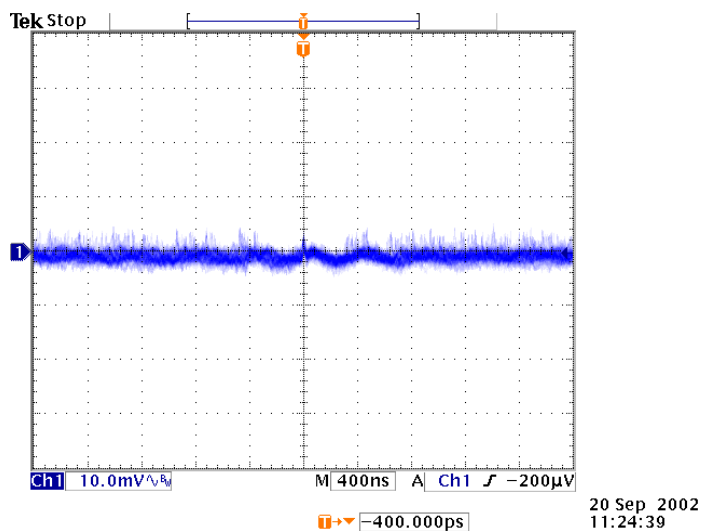

Figure 4. Input Ripple
(VIN = 3.5V, IOUT = 500mA), 20MHz Bandwidth

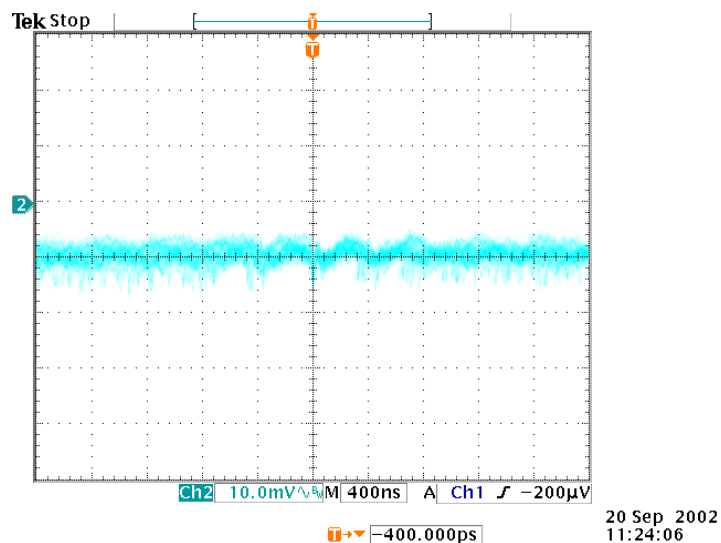
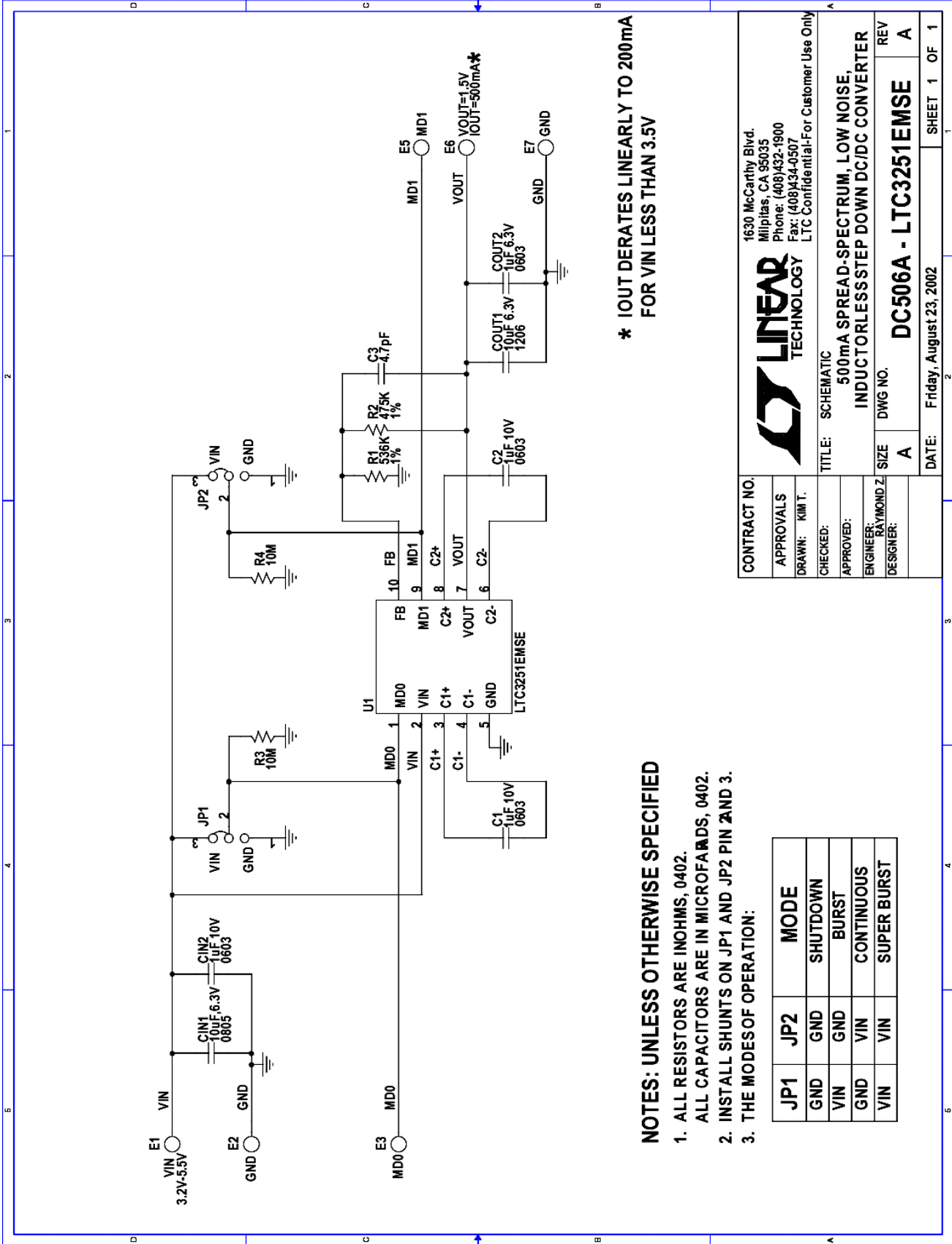

Figure 5. 1.5V Output Ripple
(VIN = 3.5V, IOUT = 500mA), 20MHz Bandwidth

QUICK START GUIDE FOR DEMONSTRATION CIRCUIT 506

500mA SPREAD-SPECTRUM, LOW NOISE, INDUCTORLESS STEP DOWN DC/DC CONVERTER



* IOUT DERATES LINEARLY TO 200mA FOR VIN LESS THAN 3.5V

NOTES: UNLESS OTHERWISE SPECIFIED

1. ALL RESISTORS ARE IN OHMS, 0402.
2. ALL CAPACITORS ARE IN MICROFARADS, 0402.
3. INSTALL SHUNTS ON JP1 AND JP2 PIN 2 AND 3.
3. THE MODES OF OPERATION:

JP1	JP2	MODE
GND	GND	SHUTDOWN
VIN	GND	BURST
GND	VIN	CONTINUOUS
VIN	VIN	SUPER BURST

CONTRACT NO.		1630 McCarthy Blvd. Milpitas, CA 95035 Phone: (408)432-1900 Fax: (408)434-0507 LTC Confidential-For Customer Use Only	
APPROVALS		LINEAR TECHNOLOGY	
DRAWN: KIM T.		TITLE: SCHEMATIC	
CHECKED:		500mA SPREAD-SPECTRUM, LOW NOISE, INDUCTORLESS STEP DOWN DC/DC CONVERTER	
APPROVED:		SIZE A	
ENGINEER: RAYMOND Z.		DWG NO. DC506A - LTC3251EMSE	
DESIGNER:		REV A	
DATE: Friday, August 23, 2002		SHEET 1 OF 1	

QUICK START GUIDE FOR DEMONSTRATION CIRCUIT 506

500mA SPREAD-SPECTRUM, LOW NOISE, INDUCTORLESS STEP DOWN DC/DC CONVERTER

Linear Technology Corporation
LTC3251EMSE
 500mA SPREAD-SPECTRUM, LOW NOISE,
 INDUCTORLESS STEP DOWN DC/DC CONVERTER
 ENG: RAYMOND Z.

BILL OF MATERIALS
DC506A
QTY-825
 10/18/02
 1:33 PM

Item	Qty	Reference	Part Description	Manufacture / Part #	Kit Qty
				NUMBER OF BOARDS =	825
1	1	CIN1	CAP., X5R 10uF 6.3V, 0805	TAIYO YUDEN, JMK212BJ106MG	825
2	3	C1,C2,CIN2	CAP., X5R 1uF 10V,0603	TAIYO YUDEN, LMK107BJ105MA	2475
3	1	COU1	CAP., X5R 10uF 6.3V,1206	TAIYO YUDEN, JMK316BJ106ML	825
4	1	COU2	CAP., X5R 1uF 6.3V,0603	TAIYO YUDEN, JMK107BJ105MA	825
5	1	C3	CAP., NPO 4.7pF 50V,0402	AVX, 04025A4R7CAT	825
6	6	E1,E2,E3,E5,E6,E7	TP, TURRET, .094"	MILL-MAX, 2501-2	4950
7	2	JP1,JP2	JMP, 1X3 PINS, .079	COMM CON, 2802S-03G2	1650
8	2	SHUNTS FOR JP1 AND JP2	SHUNT, 2 PINS, .079"	COMM CON, CCIJ2mm-138G	1650
9	1	R1	RES, 536K 1%, 0402	AAC, CR05-5363FM	825
10	1	R2	RES, 475K 1%, 0402	AAC, CR05-4753FM	825
11	2	R3,R4	RES, 10M 5%, 0402	AAC, CR05-106JM	1650
12	1	U1	IC, LTC3251EMSE, MSE10	LINEAR TECH., LTC3251EMSE	825
13	4	MTG HOLES AT 4 CORNERS	STANDOFF, NYLON HEX #4-40 x 1/4"	MICRO PLASTICS, #14HTSP101	3300
14	4		SCREW, #4-40 x 1/4	ANY	3300
			NOTES: UNLESS OTHERWISE SPECIFIED		
			1. ALL RESISTORS ARE IN OHMS, 0402.		
			2. INSTALL SHUNTS ON JP1 AND JP2 PIN 2 AND 3.		
			3. INSTALL 4 STANDOFF COMPONENTS ON BOTTOM SIDE.		

QUICK START GUIDE FOR DEMONSTRATION CIRCUIT 506

500MA SPREAD-SPECTRUM, LOW NOISE, INDUCTORLESS STEP DOWN DC/DC CONVERTER

APPROVED VENDOR LIST

VENDOR	PHONE NUMBER	PART TYPE	WEBSITE ADDRESS
AAC (was TAD)	(800) 508-1521	CHIP RESISTORS	
AAC (was TAD)	(714) 255-9186		
AAVID	(714) 556-2665	HEAT SINKS	
ALLEN BRADLEY	(800) 592-4888	CARBON RESISTORS	
AMP	(717) 564-0100	PC MOUNT BNC	
APEM	(718) 246-1007	SMD TOGGLE/PB SWITCH	
API DELEVAN	(716) 652-3600	INDUCTORS	
AVX	(843) 946-0362	CHIP CAPS	
AVX	(843) 946-0524	CHIP RESISTORS	
AVX	(207) 282-5111	TANTALUM CAPS	
AVX	(843) 946-0323	HIGH VOLTAGE CAPS	
BERG	(800) 237-2374	CONNECTORS	
BH ELECTRONICS	(952) 894-9590	INDUCTORS	
BI TECHNOLOGIES	(714) 447-2656	TRANSFORMERS	
BI TECHNOLOGIES	(714) 447-2345	RES./RES. NETWORKS	
BOURNS	(801) 750-7253	POTENTIOMETERS, SIPS	
CADDOCK ELECTRONICS	(541) 496-0700	HIPO. RES., SIPS, DIPS	
CENTRAL SEMI	(631) 435-1110	SMALL SIGNAL DISCRETES	
CHICAGO MINIAT. LAMP	(201) 489-8989	LEDS	
COILCRAFT	(847) 639-6400	INDUCTORS	
COMM CON	(626) 301-4200	HEADERS, SHUNTS	
CONNEX	(805) 378-6464	BNC CONNECTORS	
COOPER ELECT. TECH.	(561) 752-5000	INDUCTORS	
CORNELL DUBILIER	(508) 996-8561	CAPACITORS	
CTS	(219) 293-7511	RESISTOR ARRAYS	
CUI-STACK	(503) 643-4899	POWER CONNECTORS	
DALE (see Vishay)	(605) 665-1627	INDUCTORS	
DALE (see Vishay)	(605) 665-9301	SENSE RESISTORS	
DATA DISPLAY PRODUCT	(800) 421-6815	LEDS	
DIODES INC.	(805) 446-4800	DIODES	
ELECTRONIC CONCEPTS	(908) 542-7880	400V FILM CAPACITORS	
EPSON	(310) 787-6300	CRYSTALS	
FAIRCHILD	(207) 775-4502	LOGIC	
FAIRCHILD	(408) 822-2126	MOSFETS	
FAIRCHILD	(888) 522-5372	CRG (CUST. RESPONSE)	
FCI	(717) 767-8005	HOT PLUG CONNECTORS	
FUKUSHIMA	(818) 765-8300	MPC RESISTORS	
FUJI	(201) 712-0555	SCHOTTKY DIODES	
GENERAL SEMICONDUCTOR	(516) 847-3000	DIODES	
GOWANDA	(716) 532-2234	INDUCTORS	
GRAYHILL	(708) 354-1040	DIP SWITCHES	
HARRIS	(800) 442-7747	LOGIC	
HEWLETT PACKARD	(800) 235-0312	IR LED	
HITACHI	(408) 433-1990	RF POWER AMPS	

QUICK START GUIDE FOR DEMONSTRATION CIRCUIT 506

500MA SPREAD-SPECTRUM, LOW NOISE, INDUCTORLESS STEP DOWN DC/DC CONVERTER

IDT	(408) 727-6116	LOGIC IC
IR	(310) 322-3331	MOSFETS
IRC	(361) 992-7900	SENSE RESISTORS
ITW PAKTRON	(708) 667-3444	CAPACITORS
JOHNSON COMPONENTS	(650) 948-6533	RF CONNECTORS
JOHNSON COMPONENTS	(760) 434-5961	RF CONNECTORS
KEMET	(408) 986-0424	TANTALUM CAPS
KEMET	(864) 963-6300	CRG (CUST. RESPONSE)
KETEMA	(714) 630-0081	SURGE SUPPRESSORS
KEYSTONE	(718) 956-8900	JACKS, TURRETS
LITEON	(408) 241-4588	LEDS, DIODES
LTC	(408) 432-1900	HIGH PERF. I.C.S
MAGNETICS	(800) 245-3984	TOROID CORES ETC.
MARCON	(847) 696-2000	HIGH C/V CAPACITORS
METHODE	(800) 323-6864	ZIF SOCKETS
MF ELECTRONICS	(914) 576-6570	CRYSTAL OSCILLATORS
MICROCHIP	(602) 786-7200	MICROCONTROLLER IC
MICRO PLASTICS	(870) 453-8861	NYLON STANDOFFS
MICRO-SEMI	(617) 926-0404	DIODES
MIDCOM	(605) 886-4385	INDUCTORS
MIDCOM	(800) 643-2661	INDUCTORS
MILL-MAX	(516) 922-6000	TURRETS
MINICIRCUITS	(718) 934-4500	RF TRANSFORMERS
MOTOROLA	(800) 441-2447	LOGIC, REGS
MURATA ELECTRONICS	(770) 436-1300	CAPS., INDUCTORS,
MURATA ELECTRONICS	(800) 831-9172	CRG (CUST. RESPONSE)
MURATA ELECTRONICS	(770) 433-5789	RF DEVICES
NEC/TOKIN	(510) 324-4110	INDUCTORS/HI C/V CAPS
NICHIA	(408) 573-0933	WHITE LEDS
NICHICON	(847) 843-7500	ELECTROLYTIC CAPACITOR
ON SEMICONDUCTOR	(602) 244-6600	DISCRETE DIODES ETC.
ON SHORE	(602) 921-3000	TERMINATORS
PANASONIC	(714) 373-7334	INDUCTORS, POLY CAPS
PANASONIC	(201) 348-5217	LEDS
PANASONIC	(201) 373-7334	SWITCHES
PERICOM	(408) 435-0800	LOGIC IC
PHILIPS	(914) 246-2811	INDUCTORS
PHILIPS	(914) 247-2036	PLANAR INDUCTORS
PHILIPS	(508) 851-2200	DISCRETES, I.C.s
PULSE	(619) 674-8100	INDUCTORS
QT OPTOELECTRONICS	(408) 720-1440	RF SWITCH
RAYCHEM	(800) 227-4856	FUSES
RG ALLEN	(818) 765-8300	METAL OXIDE RESISTORS
RF MICRO DEVICES	(336) 664-1233	RF2138 / RF2140
SAMTEC	(800) 726-8329	WIRE JUMPERS
SANYO	(619) 661-6835	OSCON CAPS
SCHOTT	(507) 532-3201	INDUCTORS, XFORMERS

QUICK START GUIDE FOR DEMONSTRATION CIRCUIT 506

500MA SPREAD-SPECTRUM, LOW NOISE, INDUCTORLESS STEP DOWN DC/DC CONVERTER

SCHURTER	(707) 778-6311	FUSES AND HOLDERS
SIGNATRON	(909) 464-1883	DB9 CONNECTORS
SIEMENS	(108) 257-7910	OPTO
SILICONIX	(800) 554-5565	MOSFETS
SILICONIX	(408) 988-8000	MOSFETS
SPRAGUE	(207) 324-4140	CAPACITORS
SULLINS	(760) 744-0125	HEADERS, SHUNTS
SUMIDA	(847) 956-0667	INDUCTORS
SUMIDA	(408) 982-9660	INDUCTORS
TAIYO YUDEN	(408) 573-4150	CHIP CAPS / RES.
TAIYO YUDEN	(800) 348-2496	CRG (CUST. RESPONSE)
TEKTRONIX	(800) 835-9433	SCOPE PROBE SOCKETS
TEMIC	(408) 970-5700	IR PHOTO DIODE
THERMALLOY	(972) 243-4321	HEAT SINKS
THIN FILM TECHNOLOGY	(507) 625-8445	THIN FILM CHIP RESISTORS
TOCOS	(847) 884-6664	SMD POTENTIOMETERS
TOKIN (NEC)	(510) 324-4110	CAPS., INDUCTORS,
TOKO	(847) 699-3430	RF PRODUCTS
TOSHIBA	(714) 455-2000	SINGLE GATE LOGIC
TOSHIBA	(949) 455-2000	LOGIC
UNITED CHEMICON	(847) 696-2000	ELECTROLYTIC CAPACITOR
VISHAY	(605) 665-9301	ZENER/SM. SIGNAL DIODES
VISHAY	(605) 665-9301	INDUCTORS, SENSE Rs
VITRAMON	(203) 268-6261	CERAMIC CHIP CAPACITOR
WIMA	(914) 347-2474	PAPER/FILM CAPACITORS
ZETEX	(631) 366-5068	SMALL SIGNAL DISCRETES
ZIERICK	(800) 882-8020	STAKED PINS

QUICK START GUIDE FOR DEMONSTRATION CIRCUIT 506

500mA SPREAD-SPECTRUM, LOW NOISE, INDUCTORLESS STEP DOWN DC/DC CONVERTER

REVISIONS			
REV	DESCRIPTION	APPR	DATE
A	PROTOTYPE RELEASE		

SIZE	QTY	SYM	PLTD
0.035	6	+	PLTD
0.094	6	×	PLTD
0.07	2	□	NPLTD
0.125	4	◇	PLTD
0.015	17	⊗	PLTD

NOTES : Unless Otherwise Specified

- MATERIAL : FR4 OR EQUIVALENT EPOXY, 2 OZ. COPPER CLAD THICKNESS .062 +/- .006 TOTAL OF 2 LAYERS.
- FINISH : ALL PLATED HOLES .001 MIN. / .0015 MAX. COPPER PLATE ELECTRODEPOSITED TIN-LEAD COMPOSITION BEFORE REFLOW , SOLDER MASK OVER BARE COPPER (SNOBC).
- SOLDER MASK : BOTH SIDES USING LPI OR EQUIVALENT.
- SILKSCREEN : USING WHITE NON-CONDUCTIVE EPOXY INK.
- UNUSED SMD COMPONENTS SHOULD BE FREE OF SOLDER.
- FILL UP ALL VIAS WITH SOLDER.
- SCORING:

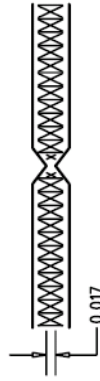

8. PLEASE LOOK AT THE README FILE FOR THE OTHER REQUIREMENTS.

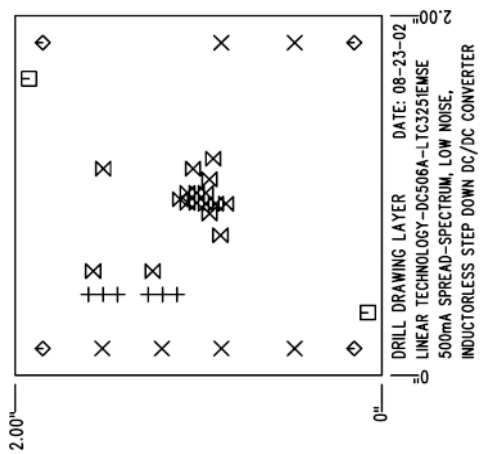

SHOWN FROM COMPONENT SIDE

APPROVALS		INIT		DATE	
DRAWN					
CHECK					
DESIGN	KM T.	08-23-02			
ENGR	RAYMOND Z.	08-23-02			
SCALE = NONE					

		1630 McCarthy Blvd. Milpitas, CA 95035 PH: (408)432-1900	
TITLE: FABRICATION DRAWING 500mA SPREAD-SPECTRUM, LOW NOISE INDUCTORLESS STEP DOWN DC/DC CONVERTER			
SIZE	A	IDEMO	REV. A
DES-0000			SHT 1 of 1

QUICK START GUIDE FOR DEMONSTRATION CIRCUIT 506

500mA SPREAD-SPECTRUM, LOW NOISE, INDUCTORLESS STEP DOWN DC/DC CONVERTER

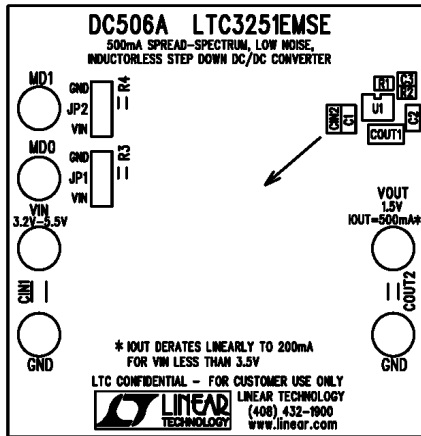

TOP SILKSCREEN DATE: 08-23-02
LINEAR TECHNOLOGY-DC506A-LTC3251EMSE
500mA SPREAD-SPECTRUM, LOW NOISE,
INDUCTORLESS STEP DOWN DC/DC CONVERTER

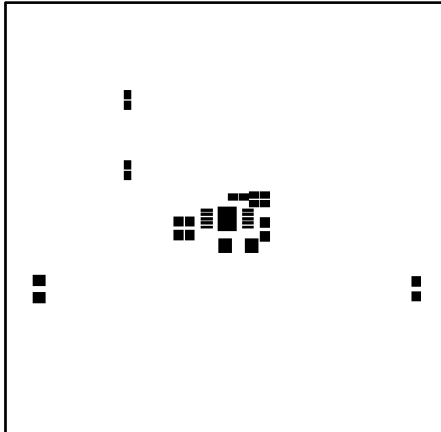

TOP SOLDER PASTE DATE: 08-23-02
LINEAR TECHNOLOGY-DC506A-LTC3251EMSE
500mA SPREAD-SPECTRUM, LOW NOISE,
INDUCTORLESS STEP DOWN DC/DC CONVERTER

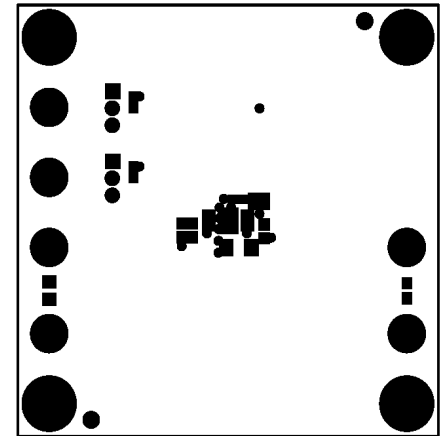

TOP SOLDER MASK DATE: 08-23-02
LINEAR TECHNOLOGY-DC506A-LTC3251EMSE
500mA SPREAD-SPECTRUM, LOW NOISE,
INDUCTORLESS STEP DOWN DC/DC CONVERTER

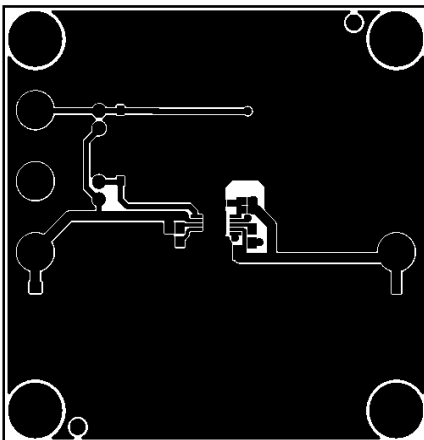

LAYER 1 - TOP LAYER DATE: 08-23-02
LINEAR TECHNOLOGY-DC506A-LTC3251EMSE
500mA SPREAD-SPECTRUM, LOW NOISE,
INDUCTORLESS STEP DOWN DC/DC CONVERTER

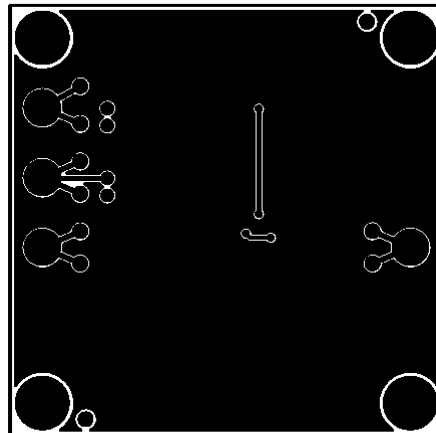

LAYER 2 - BOTTOM LAYER DATE: 08-23-02
LINEAR TECHNOLOGY-DC506A-LTC3251EMSE
500mA SPREAD-SPECTRUM, LOW NOISE,
INDUCTORLESS STEP DOWN DC/DC CONVERTER

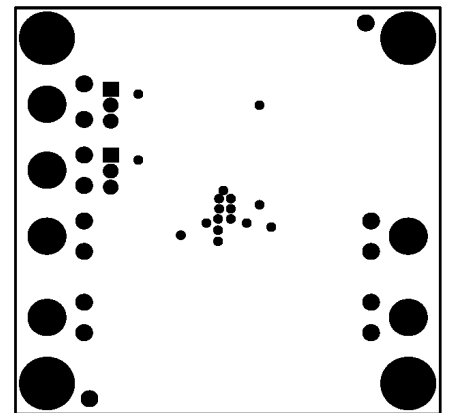

BOTTOM SOLDER MASK DATE: 08-23-02
LINEAR TECHNOLOGY-DC506A-LTC3251EMSE
500mA SPREAD-SPECTRUM, LOW NOISE,
INDUCTORLESS STEP DOWN DC/DC CONVERTER

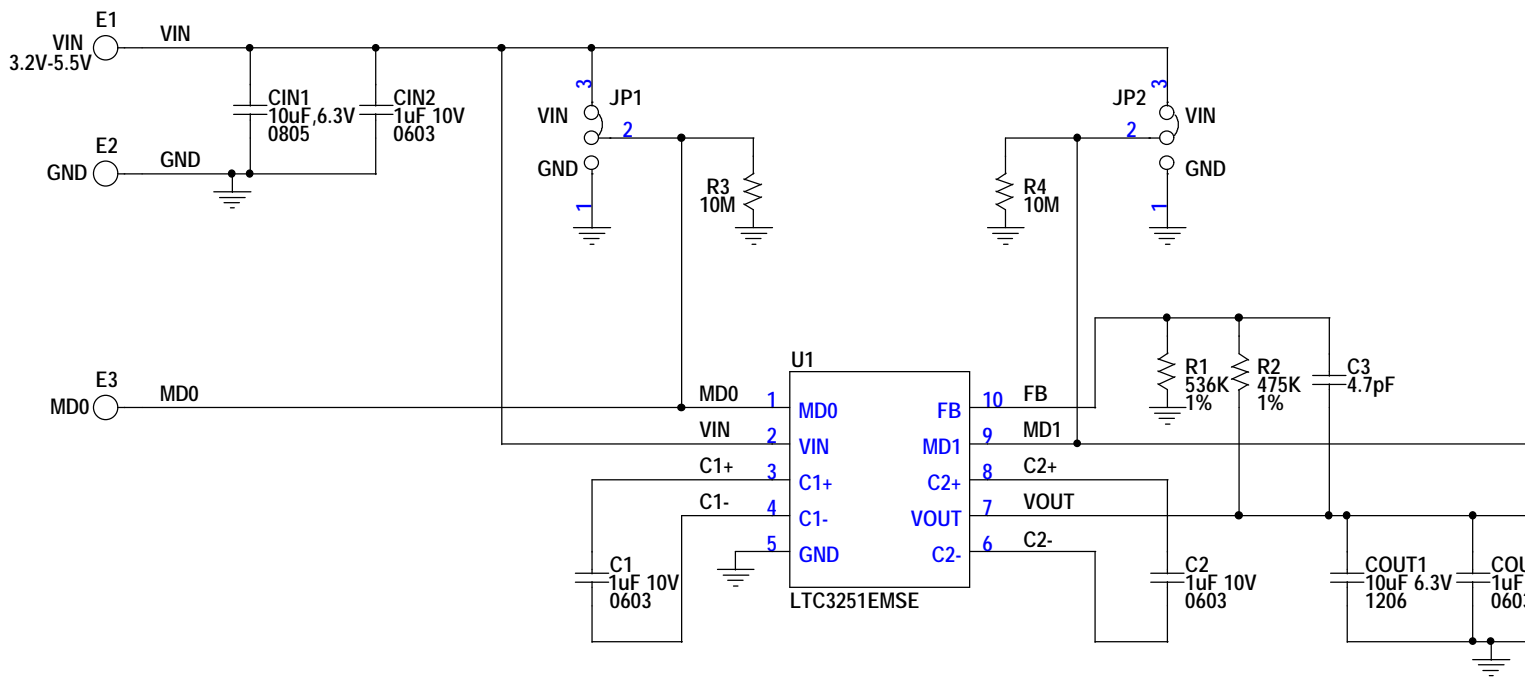

NOTES: UNLESS OTHERWISE SPECIFIED

1. ALL RESISTORS ARE IN OHMS, 0402.
ALL CAPACITORS ARE IN MICROFARADS, 0402.
2. INSTALL SHUNTS ON JP1 AND JP2 PIN 2 AND 3.
3. THE MODES OF OPERATION:

JP1	JP2	MODE
GND	GND	SHUTDOWN
VIN	GND	BURST
GND	VIN	CONTINUOUS
VIN	VIN	SUPER BURST

* IOUT DE
FOR VIN

CONTRACT NO.	 LINEAR TECHNOLOGY
APPROVALS	
DRAWN: KIM T.	
CHECKED:	
APPROVED:	
ENGINEER: RAYMOND Z.	TITLE: SCHEMATIC
DESIGNER:	500mA SPREAD-S INDUCTORLESSSTE
	SIZE DWG NO.
	A DC506A
	DATE: Friday, August 23, 2002

Linear Technology Corporation

LTC3251EMSE

500mA SPREAD-SPECTRUM, LOW NOISE,
INDUCTORLESS STEP DOWN DC/DC CONVERTER
ENG: RAYMOND Z.

<i>Item</i>	<i>Qty</i>	<i>Reference</i>	<i>Part Description</i>	<i>Manufacture / Pa</i>
1	1	CIN1	CAP., X5R 10uF 6.3V, 0805	TAIYO YUDEN, JMK212
2	3	C1,C2,CIN2	CAP., X5R 1uF 10V,0603	TAIYO YUDEN, LMK107
3	1	COUT1	CAP., X5R 10uF 6.3V,1206	TAIYO YUDEN, JMK316
4	1	COUT2	CAP., X5R 1uF 6.3V,0603	TAIYO YUDEN, JMK107
5	1	C3	CAP., NPO 4.7pF 50V,0402	AVX, 04025A4R7CAT
6	6	E1,E2,E3,E5,E6,E7	TP, TURRET, .094"	MILL-MAX, 2501-2
7	2	JP1,JP2	JMP, 1X3 PINS, .079	COMM CON, 2802S-03
8	2	SHUNTS FOR JP1 AND JP2	SHUNT, 2 PINS, .079"	COMM CON, CCIJ2mm
9	1	R1	RES, 536K 1%, 0402	AAC, CR05-5363FM
10	1	R2	RES, 475K 1%, 0402	AAC, CR05-4753FM
11	2	R3,R4	RES, 10M 5%, 0402	AAC, CR05-106JM
12	1	U1	IC, LTC3251EMSE, MSE10	LINEAR TECH., LTC32
13	4	MTG HOLES AT 4 CORNERS	STANDOFF, NYLON HEX #4-40 x 1/4"	MICRO PLASTICS, #14
14	4		SCREW, #4-40 x 1/4	ANY
NOTES: UNLESS OTHERWISE SPECIFIED				
1. ALL RESISTORS ARE IN OHMS, 0402.				
2. INSTALL SHUNTS ON JP1 AND JP2 PIN 2 AND 3.				
3. INSTALL 4 STANDOFF COMPONENTS ON BOTTOM SIDE.				

X-ON Electronics

Largest Supplier of Electrical and Electronic Components

Click to view similar products for [Power Management IC Development Tools](#) *category:*

Click to view products by [Analog Devices](#) *manufacturer:*

Other Similar products are found below :

[EVAL-ADM1168LQEBZ](#) [EVB-EP5348UI](#) [MIC23451-AAAYFL EV](#) [MIC5281YMME EV](#) [DA9063-EVAL](#) [ADP122-3.3-EVALZ](#) [ADP130-0.8-EVALZ](#) [ADP130-1.2-EVALZ](#) [ADP130-1.5-EVALZ](#) [ADP130-1.8-EVALZ](#) [ADP1714-3.3-EVALZ](#) [ADP1716-2.5-EVALZ](#) [ADP1740-1.5-EVALZ](#) [ADP1752-1.5-EVALZ](#) [ADP1828LC-EVALZ](#) [ADP1870-0.3-EVALZ](#) [ADP1871-0.6-EVALZ](#) [ADP1873-0.6-EVALZ](#) [ADP1874-0.3-EVALZ](#) [ADP1882-1.0-EVALZ](#) [ADP199CB-EVALZ](#) [ADP2102-1.25-EVALZ](#) [ADP2102-1.875EVALZ](#) [ADP2102-1.8-EVALZ](#) [ADP2102-2-EVALZ](#) [ADP2102-3-EVALZ](#) [ADP2102-4-EVALZ](#) [ADP2106-1.8-EVALZ](#) [ADP2147CB-110EVALZ](#) [AS3606-DB](#) [BQ24010EVM](#) [BQ24075TEVM](#) [BQ24155EVM](#) [BQ24157EVM-697](#) [BQ24160EVM-742](#) [BQ24296MEVM-655](#) [BQ25010EVM](#) [BQ3055EVM](#) [NCV891330PD50GEVB](#) [ISLUSBI2CKIT1Z](#) [LM2744EVAL](#) [LM2854EVAL](#) [LM3658SD-AEV/NOPB](#) [LM3658SDEV/NOPB](#) [LM3691TL-1.8EV/NOPB](#) [LM4510SDEV/NOPB](#) [LM5033SD-EVAL](#) [LP38512TS-1.8EV](#) [EVAL-ADM1186-1MBZ](#) [EVAL-ADM1186-2MBZ](#)