

DESCRIPTION

Demonstration circuit 518 is a positive input to negative output SLIC (Subscriber Line Interface Circuit) converter featuring the LTC3704 switching controller. DC518 converts 4.5V to 15V input to -24V and -70V output and provides over 200mA of output current from a 5V input. The converter operates at 200kHz with high efficiency of up to 92%. The DC518 is set to operate with current sense resistor RS1 and input voltages up to 15V. However, DC518 can be modified for No-Rsense™ operation with a 5V input voltage, provided that MOSFET drain voltage does not exceed 36V (main output set between 0V and -24V). The

circuit features an optional soft-start circuit that can be enabled or disabled with a single jumper. DC518 has a jumper to program either continuous or Burst-Mode operation and can be synchronized to an external clock of up to 400kHz. Please refer to the LTC3704 data sheet for design details and applications information.

The DC518 can produce up to 200mA at both outputs from a 5V input source.

**Design files for this circuit board are available.
Call the LTC factory.**

Table 1. Performance Summary

PARAMETER	CONDITION	VALUE
Minimum Input Voltage		4.5V
Maximum Input Voltage		15V
V_{OUT1}	$V_{IN} = 5V$ to 15V, $I_{OUT1} = 0A$ to 0.2A	-24V $\pm 3\%$
V_{OUT2}	$V_{IN} = 5V$ to 15V, $I_{OUT2} = 0A$ to 0.2A	-70V $\pm 10\%$
Typical Output Ripple V_{OUT1}	$V_{IN} = 5V$ to 15V, $I_{OUT1} = 0A$ to 0.2A	200mV _{P-P}
Typical Output Ripple V_{OUT2}	$V_{IN} = 5V$ to 15V, $I_{OUT2} = 0A$ to 0.2A	500mV _{P-P}
Nominal Switching Frequency		200kHz

QUICK START PROCEDURE

Demonstration circuit 518 is easy to set up to evaluate the performance of the LTC3704. Refer to Figure 1 for proper measurement equipment setup and follow the procedure below:

NOTE: When measuring the input or output voltage ripple, care must be taken to avoid a long ground lead on the oscilloscope probe. Measure the input or output voltage ripple by touching the probe tip directly across the Vin or Vout and GND terminals. See Figure 2 for proper scope probe technique.

1. Place jumper JP1 in the Vin position. The “Pre Reg” position is an optional bias source for applications modified for Vin higher than 36V. A bias circuit including Q4 and D5 is installed on the board in order to facilitate modifications for higher Vin.
2. With power off, connect the input power supply to Vin and GND. Make sure that the input power supply has sufficient current rating at minimum input voltage for the required output load.
3. Turn on the power at the input.

QUICK START GUIDE FOR DEMONSTRATION CIRCUIT 518

SLIC POSITIVE INPUT TO NEGATIVE OUTPUT DC/DC CONVERTER

NOTE: Make sure that the input voltage does not exceed 15V.

4. Check for the proper output voltages. $V_{OUT1} = -24V$ and $V_{OUT2} = -70V$

If there is no output, temporarily disconnect the load to make sure that the load is not set too high.

5. Once the proper output voltage is established, adjust the load within the operating range and observe the output voltage regulation, ripple voltage, efficiency and other parameter

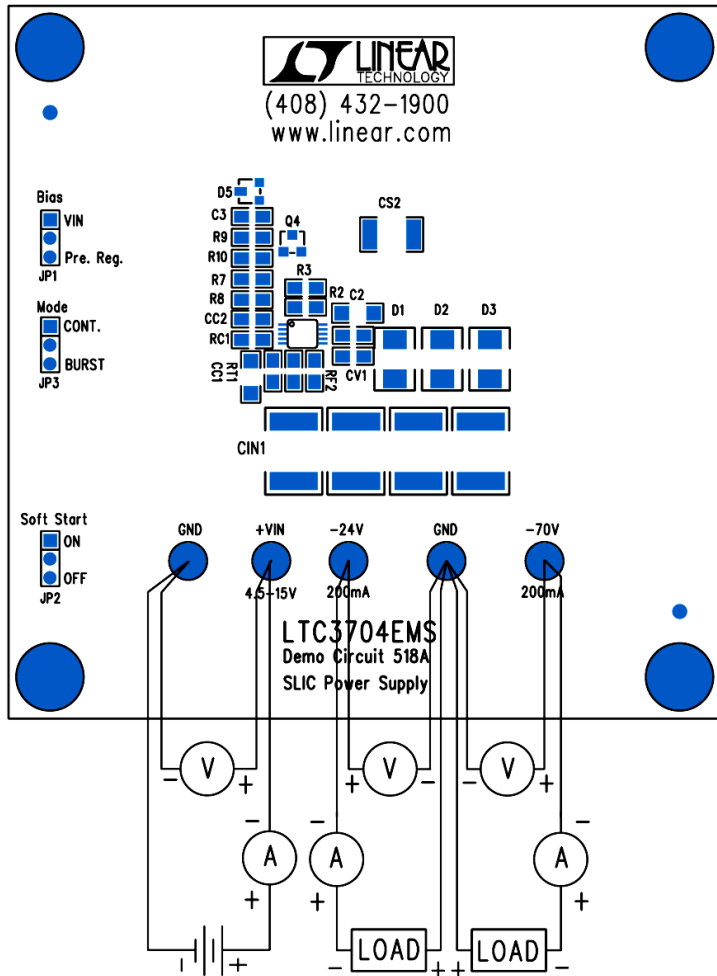

Figure 1. Proper Measurement Equipment Setup

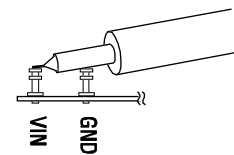

Figure 2. Scope Probe Placement for Measuring Input or Output Ripple

EXTERNAL CLOCK CONNECTION

1. To use an external clock source, turn the input power source Off and remove the Burst Mode jumper.
2. Set the clock source pulse amplitude to 5V and set the frequency between 220kHz and 300kHz.
3. Turn the clock source off.
4. Connect the clock source (pulse generator with TTL output) to the middle pin of the Burst Mode jumper.
5. Apply input power and observe the switching frequency of 200kHz.
6. Turn the clock source ON and observe the switching frequency go up to the switching frequency of the external clock.

USING NO-RSENSE MODE OF OPERATION

1. No-Rsense™ mode of operation can be used with an input voltage of 5V. The 5V input voltage combined with the -24V main output will result in a sense pin voltage of 29V, which is within the maximum rating of the sense pin of the LTC3704 controller. To use No -Rsense™ Mode of operation, the current sense resistor RS1 should be shorted out. Resistor R8 must be removed and resistor R7 should be installed.
2. Short out current sense resistor RS1.
3. Remove resistor R8.
4. Install 0Ω resistor R7.

MONITORING MOSFET CURRENT

1. To monitor the MOSFET current through resistor RS1, connect a 50 Ω coaxial cable across RS1 with the shield connected to the ground connection of RS1.
2. Connect the center conductor of the coaxial cable to the RS1 terminal that is connected to the source of MOSFET Q1. Use a 50 Ω surface mount resistor in series with the center conductor.
3. Set the scope input to 50 Ω and connect the coaxial cable to the scope.
4. Set the scope to 5mV/division or less. The current scale with 15m Ω for RS1 and 5mV/div will be .66A/div (50 Ω resistor at the input of coaxial cable forms a 2:1 divider with the 50 Ω input impedance of scope).

QUICK START GUIDE FOR DEMONSTRATION CIRCUIT 518

SLIC POSITIVE INPUT TO NEGATIVE OUTPUT DC/DC CONVERTER

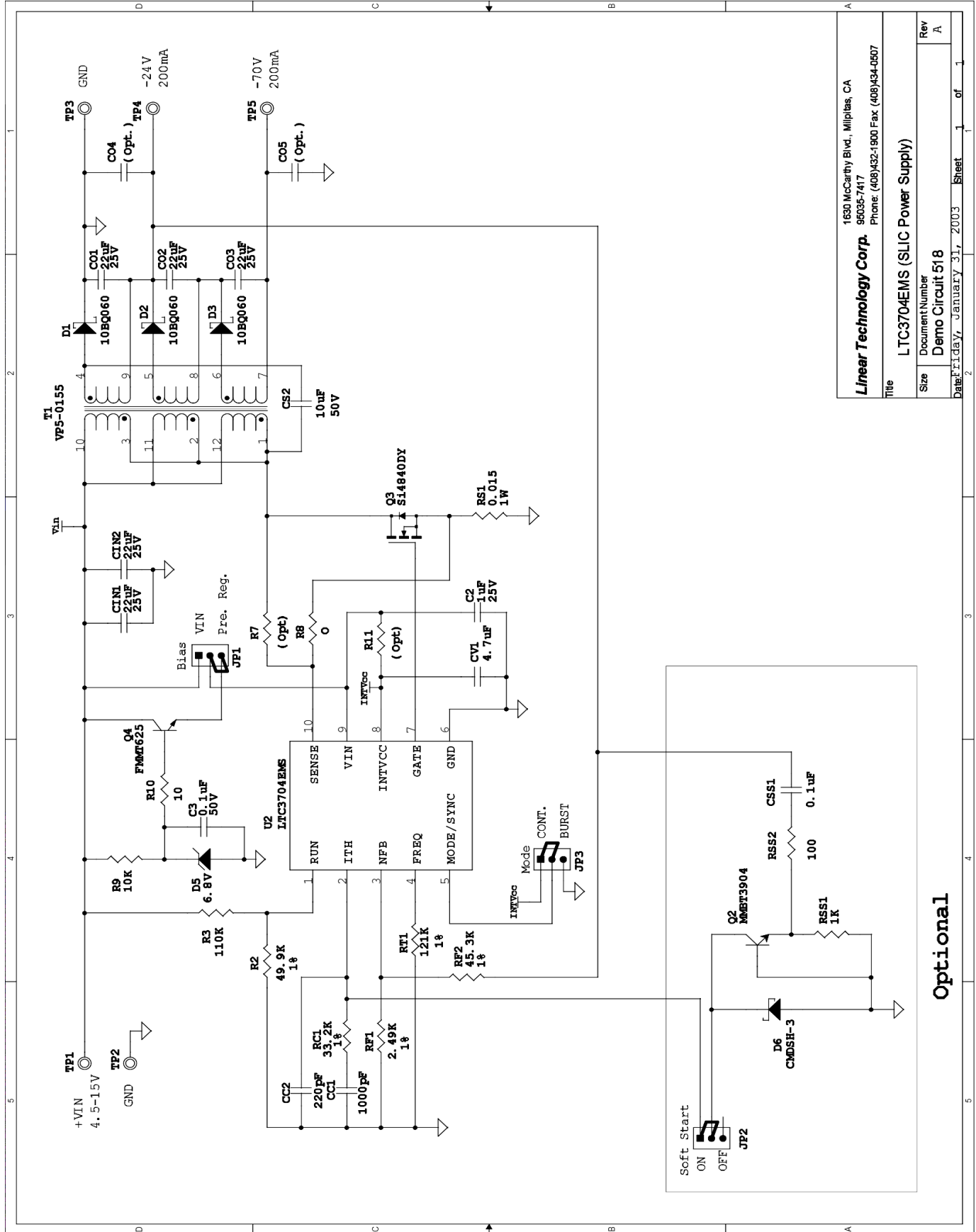

Linear Technology Corp. 1630 McCarthy Blvd., Milpitas, CA 95035-7417 Phone: (408)432-1900 Fax: (408)434-0507	
Title: LTC3704EMS (SLIC Power Supply)	
Size: Document Number Demo Circuit 518	Rev: A
Date: Friday, January 31, 2003	Sheet 1 of 1

Optional

X-ON Electronics

Largest Supplier of Electrical and Electronic Components

Click to view similar products for [Power Management IC Development Tools](#) category:

Click to view products by [Analog Devices](#) manufacturer:

Other Similar products are found below :

[EVAL-ADM1168LQEBZ](#) [EVB-EP5348UI](#) [MIC23451-AAAYFL EV](#) [MIC5281YMME EV](#) [DA9063-EVAL](#) [ADP122-3.3-EVALZ](#) [ADP130-0.8-EVALZ](#) [ADP130-1.2-EVALZ](#) [ADP130-1.5-EVALZ](#) [ADP130-1.8-EVALZ](#) [ADP1714-3.3-EVALZ](#) [ADP1716-2.5-EVALZ](#) [ADP1740-1.5-EVALZ](#) [ADP1752-1.5-EVALZ](#) [ADP1828LC-EVALZ](#) [ADP1870-0.3-EVALZ](#) [ADP1871-0.6-EVALZ](#) [ADP1873-0.6-EVALZ](#) [ADP1874-0.3-EVALZ](#) [ADP1882-1.0-EVALZ](#) [ADP199CB-EVALZ](#) [ADP2102-1.25-EVALZ](#) [ADP2102-1.875EVALZ](#) [ADP2102-1.8-EVALZ](#) [ADP2102-2-EVALZ](#) [ADP2102-3-EVALZ](#) [ADP2102-4-EVALZ](#) [ADP2106-1.8-EVALZ](#) [ADP2147CB-110EVALZ](#) [AS3606-DB](#) [BQ24010EVM](#) [BQ24075TEVM](#) [BQ24155EVM](#) [BQ24157EVM-697](#) [BQ24160EVM-742](#) [BQ24296MEVM-655](#) [BQ25010EVM](#) [BQ3055EVM](#) [NCV891330PD50GEVB](#) [ISLUSBI2CKIT1Z](#) [LM2744EVAL](#) [LM2854EVAL](#) [LM3658SD-AEV/NOPB](#) [LM3658SDEV/NOPB](#) [LM3691TL-1.8EV/NOPB](#) [LM4510SDEV/NOPB](#) [LM5033SD-EVAL](#) [LP38512TS-1.8EV](#) [EVAL-ADM1186-1MBZ](#) [EVAL-ADM1186-2MBZ](#)