

DESCRIPTION

Demonstration circuit 526 features the LT1310 1.5A Monolithic Boost Regulator with PLL. DC526 converts a 5V input to a 12V output with an output load of up to 400mA. The operating frequency of the LT1310 is easily synchronizable over a wide frequency range. To demonstrate this, DC526 includes an on-board oscillator (based on the LT6900), which is tunable between 1.2MHz and 2.4MHz. DC526 can also be synchronized to

an external clock selecting the Ext. Sync. option (jumper JP2) and by injecting the appropriate signal into the Ext. Sync. pin. Additionally a work area is provided on the backside of the board to simplify customization of the demo board.

Design files for this circuit board are available. Call the LTC factory.

Table 1. Performance Summary

PARAMETER	CONDITION	VALUE
Minimum Input Voltage		3V
Shutdown current	V _{IN} 5V	2μA
Maximum Input Voltage		12V
V _{OUT}	V _{IN} = 3V to 7V, I _{OUT} = 0 to 250mA	12V ±3%
Switching Frequency		Tunable 1.2Mhz to 2.4Mhz

QUICK START PROCEDURE

Demonstration circuit 526 is easy to set up to evaluate the performance of the LT1310. Refer to Figure 1 for proper measurement equipment setup and follow the procedure below:

NOTE: When measuring the input or output voltage ripple, care must be taken to avoid a long ground lead on the oscilloscope probe. Measure the input or output voltage ripple by touching the probe tip directly across the Vin or Vout and GND terminals. See Figure 2 for proper scope probe technique.

1. Place SHDN jumper JP1 in the ON position.
2. Select either the internal or external sync source via the SYNC jumper, JP2

3. With power off, connect the input power supply to Vin and GND.

4. Turn on the power at the input.

NOTE: Make sure that the input voltage does not exceed 12V.

5. Check for the proper output voltages. Vout = 12V

If there is low output, temporarily disconnect the load to make sure that the load is not set too high.

6. Once the proper output voltage is established, adjust the load within the operating range and observe the output voltage regulation, ripple voltage, efficiency and other parameters.

QUICK START GUIDE FOR DEMONSTRATION CIRCUIT 526

MONOLITHIC BOOST CONVERTER WITH PHASE-LOCKED LOOP

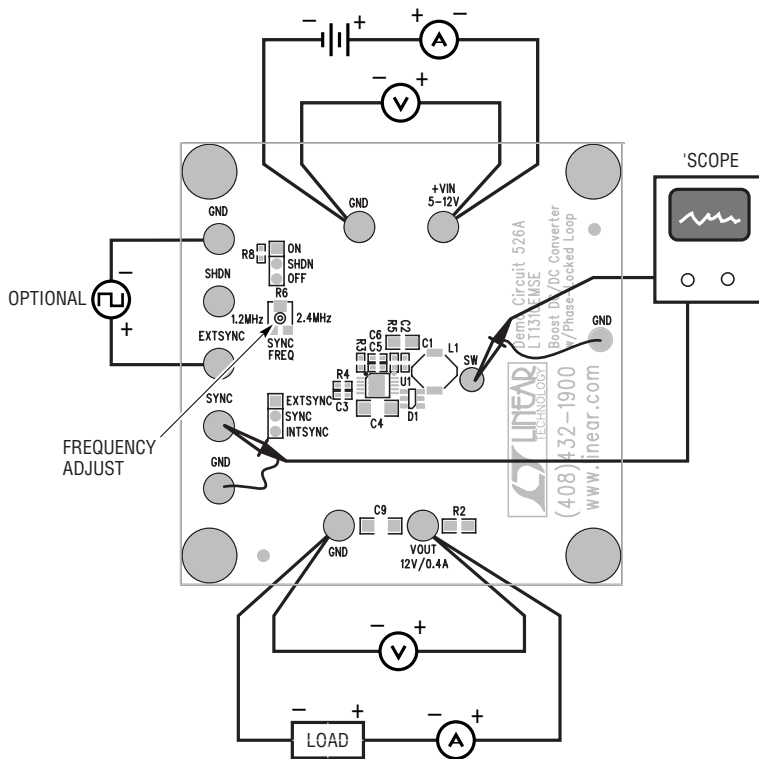

Figure 1. Proper Measurement Equipment Setup

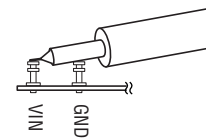

Figure 2. Scope Probe Placement for Measuring Input or Output Ripple

DC526 PINS

SHDN PIN

The board can be placed in shutdown either by grounding the shutdown pin or by placing the SHDN jumper JP1 in the OFF position. The shutdown current is less than $2\mu\text{A}$ if the jumper is used and is about $150\mu\text{A}$ if the pin is grounded due to the on-board pull-up resistor R8.

EXTSYNC PIN

The EXTSYNC pin is the input for an external frequency source to allow the board to be synchronized to a system clock. This clock signal must be between 1.2MHz and 2.4MHz and meet the voltage and timing requirements outlined in the LT1310 data sheet.

SYNC PIN

The SYNC terminal is tied directly to the SYNC pin of the LT1310. Phase locking of the LT1310 to the signal at the SYNC pin can be observed by simultaneously observing the SYNC signal and the SW pin of the LT1310. Access to the SW pin is provided by the small turret labeled SW. When synchronization has occurred these two signals are in a fixed relationship to each other and an oscilloscope should show both as stable waveforms. In the event that the synchronization frequency is adjusted beyond the available tuning range then only the signal that is used for the trigger source of the scope will appear stable.

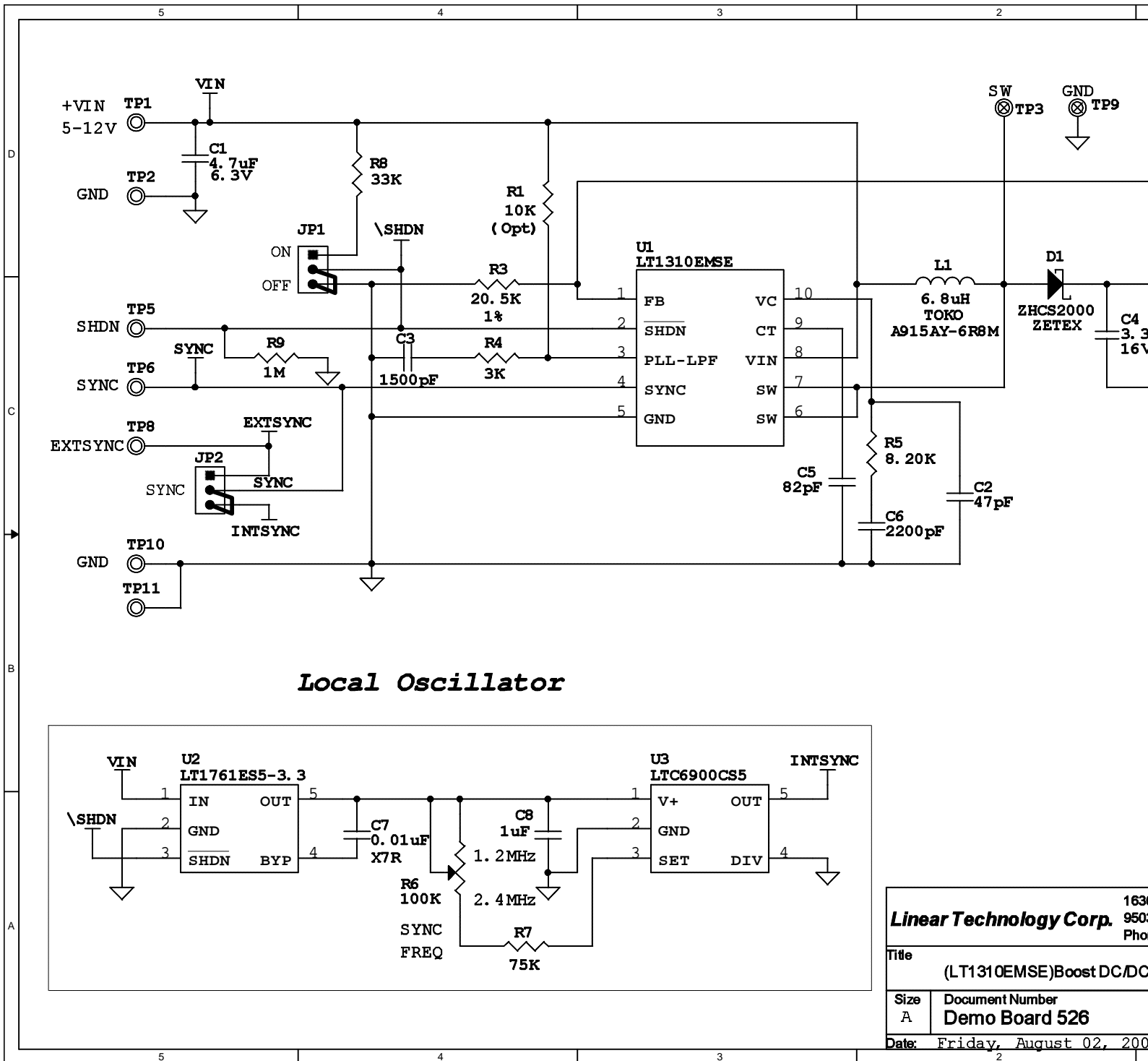

Local Oscillator

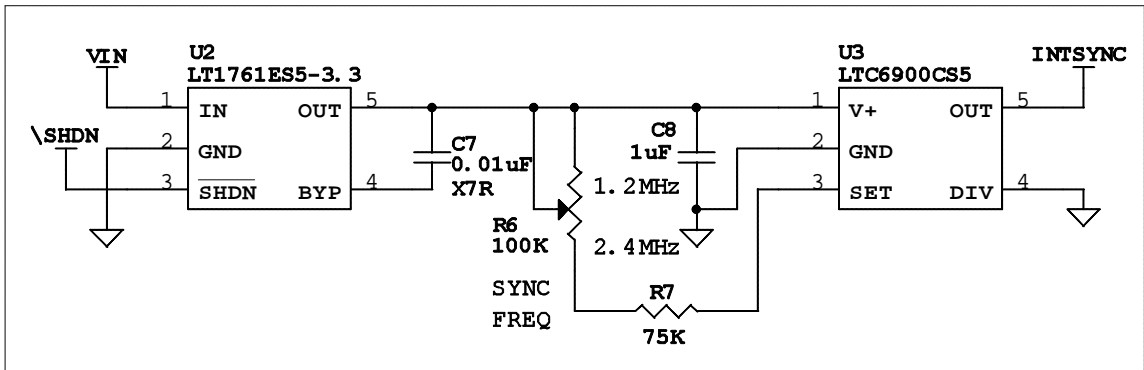

Linear Technology Corp. 1630 9500 Phoenix, AZ	
Title (LT1310EMSE)Boost DC/DC	
Size A	Document Number Demo Board 526
Date: Friday, August 02, 2002	

X-ON Electronics

Largest Supplier of Electrical and Electronic Components

Click to view similar products for [Power Management IC Development Tools](#) category:

Click to view products by [Analog Devices](#) manufacturer:

Other Similar products are found below :

[EVAL-ADM1168LQEBZ](#) [EVB-EP5348UI](#) [MIC23451-AAAYFL EV](#) [MIC5281YMME EV](#) [DA9063-EVAL](#) [ADP122-3.3-EVALZ](#) [ADP130-0.8-EVALZ](#) [ADP130-1.2-EVALZ](#) [ADP130-1.5-EVALZ](#) [ADP130-1.8-EVALZ](#) [ADP1714-3.3-EVALZ](#) [ADP1716-2.5-EVALZ](#) [ADP1740-1.5-EVALZ](#) [ADP1752-1.5-EVALZ](#) [ADP1828LC-EVALZ](#) [ADP1870-0.3-EVALZ](#) [ADP1871-0.6-EVALZ](#) [ADP1873-0.6-EVALZ](#) [ADP1874-0.3-EVALZ](#) [ADP1882-1.0-EVALZ](#) [ADP199CB-EVALZ](#) [ADP2102-1.25-EVALZ](#) [ADP2102-1.875EVALZ](#) [ADP2102-1.8-EVALZ](#) [ADP2102-2-EVALZ](#) [ADP2102-3-EVALZ](#) [ADP2102-4-EVALZ](#) [ADP2106-1.8-EVALZ](#) [ADP2147CB-110EVALZ](#) [AS3606-DB](#) [BQ24010EVM](#) [BQ24075TEVM](#) [BQ24155EVM](#) [BQ24157EVM-697](#) [BQ24160EVM-742](#) [BQ24296MEVM-655](#) [BQ25010EVM](#) [BQ3055EVM](#) [NCV891330PD50GEVB](#) [ISLUSBI2CKIT1Z](#) [LM2744EVAL](#) [LM2854EVAL](#) [LM3658SD-AEV/NOPB](#) [LM3658SDEV/NOPB](#) [LM3691TL-1.8EV/NOPB](#) [LM4510SDEV/NOPB](#) [LM5033SD-EVAL](#) [LP38512TS-1.8EV](#) [EVAL-ADM1186-1MBZ](#) [EVAL-ADM1186-2MBZ](#)