

Triple Hot Swap Controller with Multifunc-

DESCRIPTION

Demonstration circuit DC537A is designed to evaluate the performance of the LTC4230 Triple Hot Swap Controller with multifunction current control. The board demonstrates all possible operation modes: power-up and power-down, when power rails turn on or turn off, steady state with constant load and overload conditions.

The board contains one LTC4230 Controller, three power channels, three resistive feedback signal dividers, an ON pin circuit, and a circuit for configuration of the FAULT pin function. Each power channel includes a series connected power MOSFET and sense resistor.

Design files for this circuit board are available. Call the LTC factory.

LTC is a trademark of Linear Technology Corporation.

PERFORMANCE SUMMARY Specifications are at TA = 25°C

PARAMETER	CONDITIONS	MIN	TYP	MAX	UNITS
Supply Voltage V _{CC1}	V _{CC2} ≤ V _{CC1} V _{CC3} ≤ (V _{CC1} -1)	2.700		16.5	V
Supply Voltage V _{CC2}		2.375		16.5	
Supply Voltage V _{CC3}		1.700		16.5	
Undervoltage Lockout, Channel 1	V _{CC1} Low to High Transition	2.13	2.35	2.52	V
Undervoltage Lockout, Channel 2	V _{CC2} Low to High Transition	1.98	2.15	2.32	V
Undervoltage Lockout, Channel 3	V _{CC3} Low to High Transition	1.09	1.19	1.29	V
Circuit Breaker Trip Current	Fast Comparator	19.1	21.4	23.8	A
	Slow Comparator	5.65	7.14	8.65	
GATEn Pin Pull-Up Slew Rate	Charge Pump On, 0 ≤ V _{GATE} ≤ 0.2V	0.42	0.74	1.13	V/ms
Normal Gate Pull-Down Slew Rate	ON Low, GATE=5V		14.70		V/ms
Fast Gate Pull-Down Slew Rate	FAULT Latched and Circuit Breaker Tripped or in UVLO		10.0		V/μs
ON High Threshold Voltage	ON Low to High Transition	1.250	1.314	1.380	V
ON Low Threshold Voltage	ON High to Low Transition	1.172	1.234	1.27	V
FB Low Threshold Voltage	FB High to Low Transition	1.209	1.234	1.259	V
FB Hysteresis			3		mV
Supply Voltage V _{CC1}	V _{CC2} ≤ V _{CC1} V _{CC3} ≤ (V _{CC1} -1)	2.700		16.5	V
Supply Voltage V _{CC2}		2.375		16.5	
Supply Voltage V _{CC3}		1.700		16.5	
Undervoltage Lockout, Channel 1	V _{CC1} Low to High Transition	2.13	2.35	2.52	V
Undervoltage Lockout	V _{IN} Rising, 0°C < T _A < 85°C			2.5	V
	V _{IN} Rising			2.6	
	V _{IN} Falling	1.6			

OPERATING PRINCIPLES

The LTC4230 is a triple hot swap controller that controls three supply voltages from 1.7V to 16.5V with $V_{CC1} \geq V_{CC2} \geq V_{CC3}$.

The LTC4230 is suited to low voltage power control in applications for hot board insertion or removal and electronic circuit breaker functions. The LTC4230 provides a rich set of features to support Hot Swap applications including:

- Under voltage lockout
- Programmable over voltage protection
- Programmable soft start with inrush current limiting
- Dual level over current fault protection
- Programmable over current response time
- Automatic retry or latched mode operation
- User-programmable supply voltage power-up rate
- Output voltages V_{OUTn} monitoring and RESETn signaling
- Spurious RESETn signal elimination by the glitch filter

Available in a 20 lead SSOP package, the LTC4230 is showcased on demonstration circuit DC537A configured for 1.7 to 16.5 volt operation with a slow comparator current limit protection in the range of 5.71A - 8.57A and a fast comparator – in the range of 19.3A - 23.6A.

Pull-up resistors are provided to monitor the RESETn pin signals.

MOSFET gate capacitors C7, C8, C9 define the output voltage slew rate. Initially the board is populated for nominal 0.74V/ms slew rate in each power channel.

The external ON control signal should be higher than 2.8V.

Three optional Zener diodes (D4, D5, and D6) can be used to protect the system against supply over-voltage condition on the load side of the pass transistor.

QUICK START PROCEDURE

Demonstration circuit 537 is easy to set up to evaluate the performance of the LTC4230. Refer to Figure 1 for proper board connections with power supplies, loads, and the ON control signal source.

Demonstration Circuit 537 has three optional components R13, R10, and R7 for the output voltage monitoring value adjustments and one user configurable jumper JP1 option.

Calculate R13, R10, and R7 resistors based at the selected channel voltages and install them on the board.

Place jumper J1 in the AUTORETRY position to evaluate automatic retry when current limit is reached, or in the STATUS position to evaluate latched mode operation.

With power off, connect three power supplies capable of supplying 25A to the appropriate V1_IN, V2_IN, V3_IN turrets and GND. Supplies voltages should satisfy the conditions shown in the PERFORMANCE SUMMARY and $V_{CC1} \cdot V_{CC2}; V_{CC3} \cdot (V_{CC1} - 1)$.

Connect the ON pin to a signal source capable of developing $16V > V_{ON} > 1.39V$ to the turret labeled ON/OFF and be sure that the ON signal is initially zero (low).

NO LOAD TEST

Turn on the power supplies, verify the input voltages, and then switch the ON control signal from low to high ($\geq 1.39V$).

All three outputs should come up.

Verify the RESETn turret signals. All three voltages should be lower than 0.5V.

Switch the ON control signal from high to low. All outputs should go down.

RATED LOAD TEST

Repeat the test with resistive loads connected to each output. Be sure that the current in each channel does not exceed 5.65A current limit.

OVER CURRENT FAULT TEST

Three separate tests are needed to verify the circuit breaker functions. First two tests run with conditions for slow comparator operation; third test – for fast comparator operation. Monitor the turn off events with a digital storage scope.

1. With the outputs unloaded and the circuit functioning, connect a load to the selected channel output, which will draw 10A current.

The channel will fault. Verify latch off and automatic retry modes by changing the jumper JP1 position.

Repeat this test for each channel.

2. With the jumper JP1 in the STATUS position, the board unpowered and the ON control signal high, connect a load capable of drawing 10A to any channel output. Leave the other two channels unloaded.

First, turn the two unloaded channel supplies on. Then turn on the third supply and verify that LTC4230 is in the latch mode.

NOTE. This test can be run only with the components initially installed on the board and the channel operating voltage $V_{CCn} = 12V$. Otherwise, the MOSFET can operate out of the safe operating area, and not survive. Higher operating voltages or higher currents require a larger FET.

3. Adjust the resistive load to draw 24A current in channel 1 to demonstrate the FAST comparator fault..

With the jumper JP1 in the STATUS position, the unloaded outputs and the circuit functioning, connect this load to the channel 1 output.

Verify that LTC4230 is in the latch mode.

UNDER VOLTAGE LOCKOUT TEST

Test under voltage lockout functionality by reducing the input voltage below 2.15V for channel 1, below 1.98V for channel 2, and below 1.09V for channel 3.

CHANNEL SEQUENCING

If power on sequencing is desired, remove the RESETn pin pull-ups. Choose the channel sequence in the power up mode. Connect the RESETn1 pin to the GATEn2 pin; connect RESETn2 pin to the GATEn3 pin. The additional indexes 1, 2, 3 show channel sequencing order. As FBn1 pin exceeds its threshold RESETn1 will release the MOSFET GATEn2 pin; as the FBn2 pin exceeds its threshold, RESETn2 will release the channel MOSFET GATEn3 pin.

Apply ON signal and observe the start up sequencing.

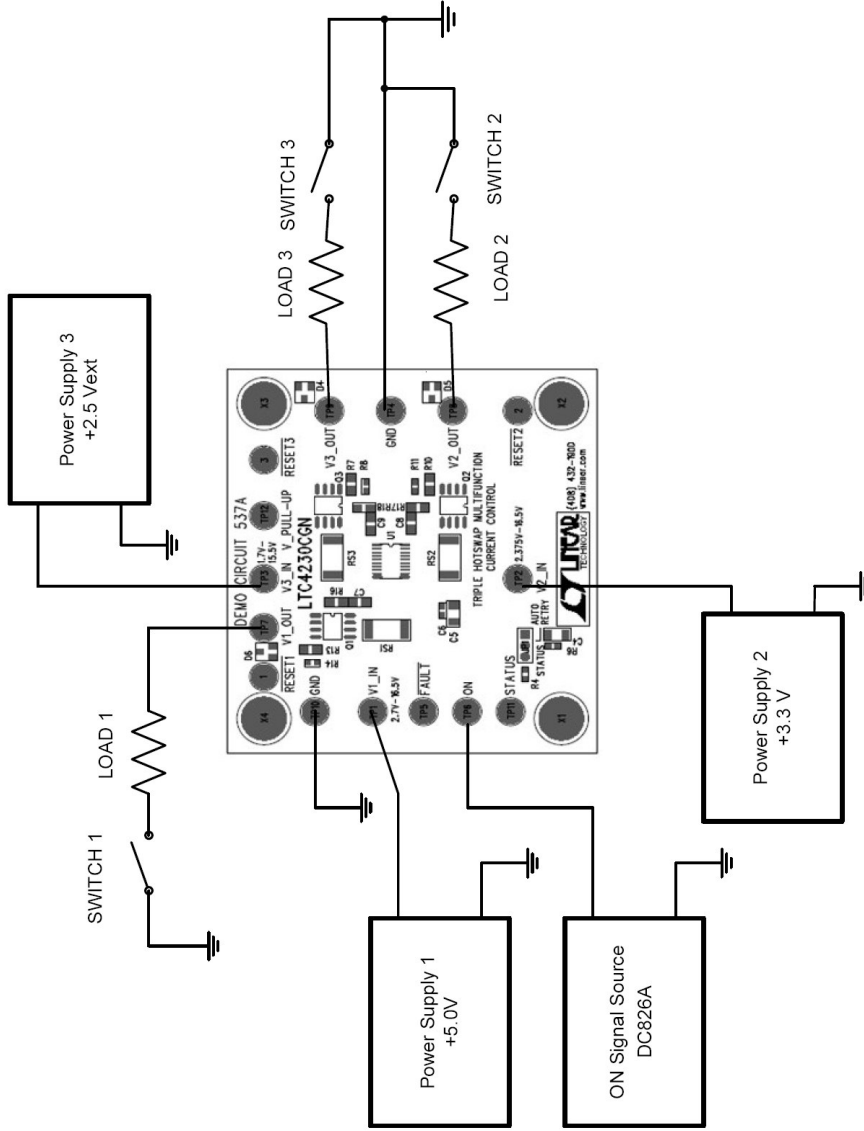
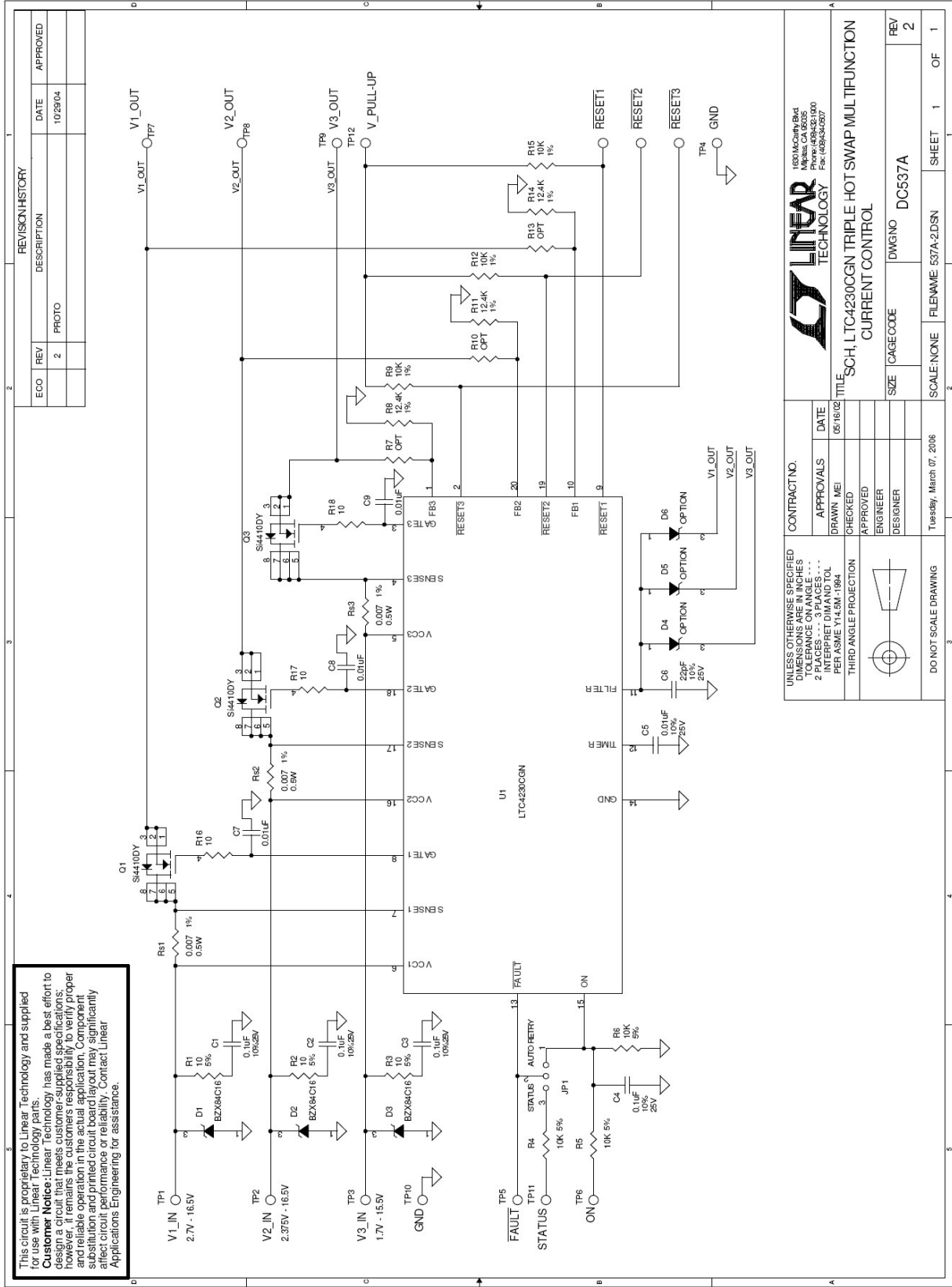

FIGURE 1
DC537A Connection for Test



This circuit is proprietary to Linear Technology and supplied for use with Linear Technology parts.
Customer Notice: Linear Technology has made a best effort to design a circuit that meets customer-supplied specifications; however, it remains the customer's responsibility to verify proper and reliable operation in the actual application. Component substitution and printed circuit board layout may significantly affect performance. Contact Linear Applications Engineering for assistance.

REVISION HISTORY				
ECO	REV	DESCRIPTION	DATE	APPROVED
	2	PROTO	10/29/04	

		1630 Massachusetts Blvd Lincoln, MA 01922 Phone: (408) 438-1900 Fax: (408) 438-6877	
CONTRACT NO.	APPROVALS	DATE	TITLE
	DRAWN MEI	05/16/02	SCH-1, LTC4230CGN TRIPLE HOT SWAP MULTIFUNCTION CURRENT CONTROL
UNLESS OTHERWISE SPECIFIED DIMENSIONS ARE IN INCHES TOLERANCE ON ANGLE ... PER ASME Y14.5M-1994	CHECKED		
THIRD ANGLE PROJECTION	APPROVED		
	ENGINEER		
	DESIGNER		
DO NOT SCALE DRAWING	Tuesday, March 07, 2006		
SCALE: NONE	FILENAME: 537A-2.DSN	SHEET 1	OF 1
SIZE	CASE CODE	DWG NO	REV
		DC537A	2

X-ON Electronics

Largest Supplier of Electrical and Electronic Components

Click to view similar products for [Power Management IC Development Tools](#) category:

Click to view products by [Analog Devices](#) manufacturer:

Other Similar products are found below :

[EVAL-ADM1168LQEBZ](#) [EVB-EP5348UI](#) [MIC23451-AAAYFL EV](#) [MIC5281YMME EV](#) [DA9063-EVAL](#) [ADP122-3.3-EVALZ](#) [ADP130-0.8-EVALZ](#) [ADP130-1.2-EVALZ](#) [ADP130-1.5-EVALZ](#) [ADP130-1.8-EVALZ](#) [ADP1714-3.3-EVALZ](#) [ADP1716-2.5-EVALZ](#) [ADP1740-1.5-EVALZ](#) [ADP1752-1.5-EVALZ](#) [ADP1828LC-EVALZ](#) [ADP1870-0.3-EVALZ](#) [ADP1871-0.6-EVALZ](#) [ADP1873-0.6-EVALZ](#) [ADP1874-0.3-EVALZ](#) [ADP1882-1.0-EVALZ](#) [ADP199CB-EVALZ](#) [ADP2102-1.25-EVALZ](#) [ADP2102-1.875EVALZ](#) [ADP2102-1.8-EVALZ](#) [ADP2102-2-EVALZ](#) [ADP2102-3-EVALZ](#) [ADP2102-4-EVALZ](#) [ADP2106-1.8-EVALZ](#) [ADP2147CB-110EVALZ](#) [AS3606-DB](#) [BQ24010EVM](#) [BQ24075TEVM](#) [BQ24155EVM](#) [BQ24157EVM-697](#) [BQ24160EVM-742](#) [BQ24296MEVM-655](#) [BQ25010EVM](#) [BQ3055EVM](#) [NCV891330PD50GEVB](#) [ISLUSBI2CKIT1Z](#) [LM2744EVAL](#) [LM2854EVAL](#) [LM3658SD-AEV/NOPB](#) [LM3658SDEV/NOPB](#) [LM3691TL-1.8EV/NOPB](#) [LM4510SDEV/NOPB](#) [LM5033SD-EVAL](#) [LP38512TS-1.8EV](#) [EVAL-ADM1186-1MBZ](#) [EVAL-ADM1186-2MBZ](#)