

## DESCRIPTION

Demonstration circuit 543 is an LTC®2920-2 Dual Voltage Margining Controller integrated with an LTC1628 Dual High Efficiency, 2-Phase Synchronous Step-Down Switching Regulator. Two 3-position switches are provided to demonstrate both high and low voltage margining. The switches margin the 5.0V and 3.3V outputs to  $\pm 10\%$  of their nominal values. By changing jumpers a slower raise and fall time be-

tween margined and un-margined voltages can be demonstrated. The total PCB footprint used by the LTC2920-2 and all of its associated components is less than .05 in<sup>2</sup>.

**Design files for this circuit board are available. Call the LTC factory.**

LTC is a Registered trademark of Linear Technology Corporation

**Table 1. Performance Summary**

| PARAMETER                        | CONDITION | MIN | TYP      | MAX | UNITS |
|----------------------------------|-----------|-----|----------|-----|-------|
| Input Voltage Range              |           | 7   |          | 24  | V     |
| Output Voltage V <sub>OUT1</sub> |           |     | 5        |     | V     |
| Output Voltage V <sub>OUT2</sub> |           |     | 3.3      |     | V     |
| Voltage Margining                |           |     | $\pm 10$ |     | %     |
| Output Current I <sub>OUT</sub>  |           |     | 10       | 12  | A     |

## QUICK START PROCEDURE

The circuit is very simple as far as the basic input and output connections are concerned, see Figure 1. However, due to the high current nature of this design, care must be exercised or unreliable results will be obtained. The first consideration is the wire gauge for input and output power connections. The load current of 12A will require at least 3 strands of AWG 18 wire or equivalent for the output power and ground connections. The input wire size is 1 to 3 strands of AWG 18 or equivalent, depending on the input voltage. There is one pair of connector terminals for the inputs of the DC543 and one pair for each output. It is important that all these connections be tightened and secured before applying power to the circuit.

The lab supply used for the input source of DC543 must be capable of supplying a current estimated at  $1.2 \times (V_{O1} \times I_{O1} + V_{O2} \times I_{O2})/V_{IN}$ . Use a lab power supply with a voltage between 7 and 24 Volts. To prevent interaction between the lab supply and the demo

board, additional low impedance electrolytic capacitors at the output of the lab supply are recommended. This is particularly important for transient load testing, especially at low input voltages.

Connect a resistive load to the output terminals of the DC543. For the 5V supply, connect a load resistor between the two output terminals with a value between 0.5 ohms and 50 ohms. For the 3.3V supply, connect a load resistor between the two output terminals with a value between 0.33 ohms and 33 ohms. Be sure to calculate the power dissipation in each resistor and select resistors with a high enough constant power rating. The demo board is shipped with the following settings:

|              |                    |
|--------------|--------------------|
| JP1 (FCB)    | INTV <sub>cc</sub> |
| JP2 (STBYMD) | 0'                 |
| JP3 (FLTCPL) | INTV <sub>cc</sub> |
| JP6 (RUN1)   | '1'                |

# QUICK START GUIDE FOR DEMONSTRATION CIRCUIT 543

## LTC2920 WITH DUAL DC TO DC CONVERTER

---

JP7 (RUN2)            '1'  
JP8 (Damped)        Normal  
JP9 (Damped)        Normal

tion will cause the associated output voltage to be 10% lower than the nominal voltage.

Attach the voltmeters directly to the input and output connectors to measure the input voltage and output voltage, respectively. Place the two '3 position' switches, SW1 and SW2 in the middle position. Turn on the power supply connected to the Vin terminals and verify the nominal voltages at the Vin terminals and both sets of output terminals.

SW2 controls the 5 Volt output, SW1 controls the 3.3 Volt output. Moving a switch to the '0' position will cause the associated output voltage to be 10% higher than nominal voltage. Moving a switch to the '1' posi-

# QUICK START GUIDE FOR DEMONSTRATION CIRCUIT 543

## LTC2920 WITH DUAL DC TO DC CONVERTER

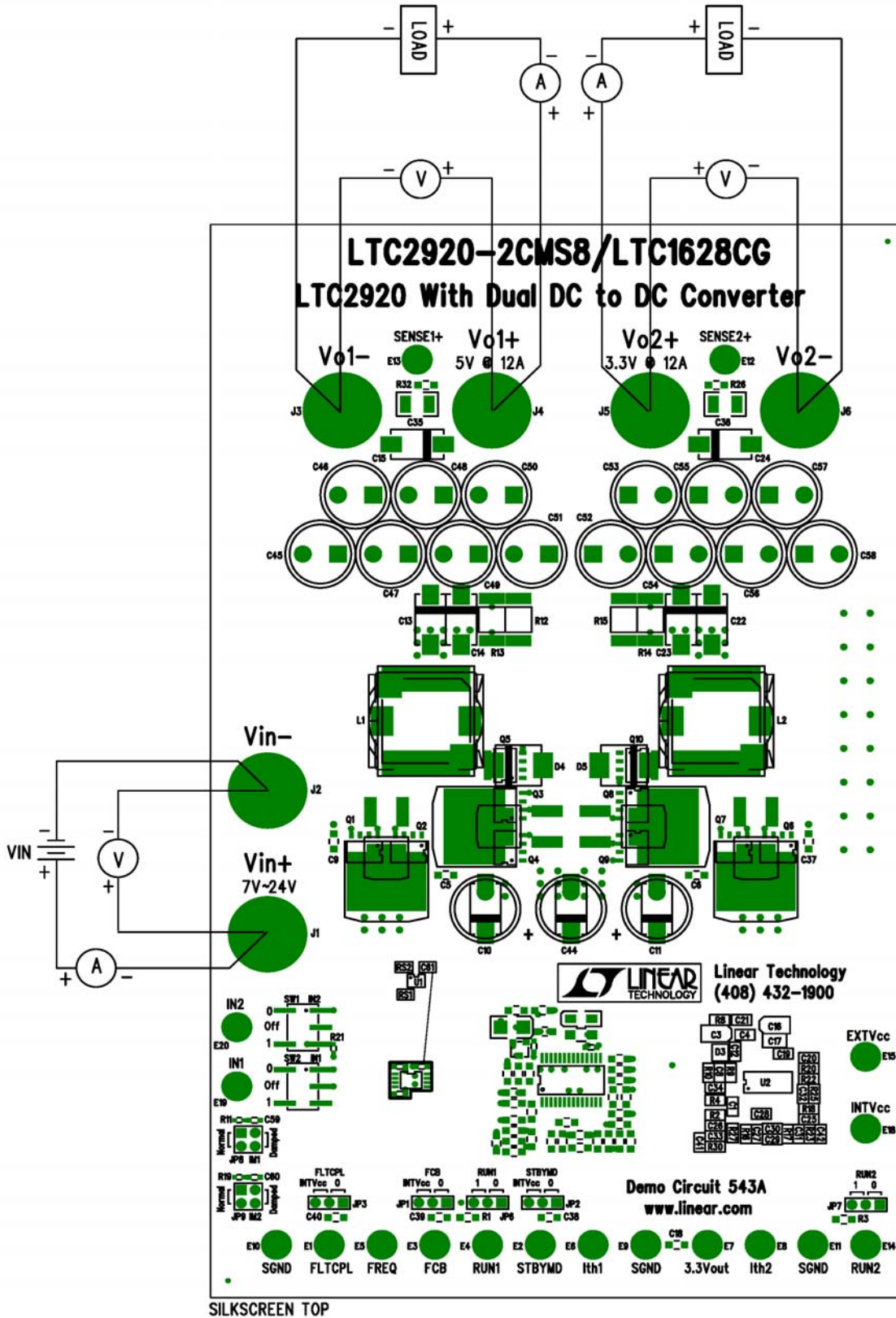
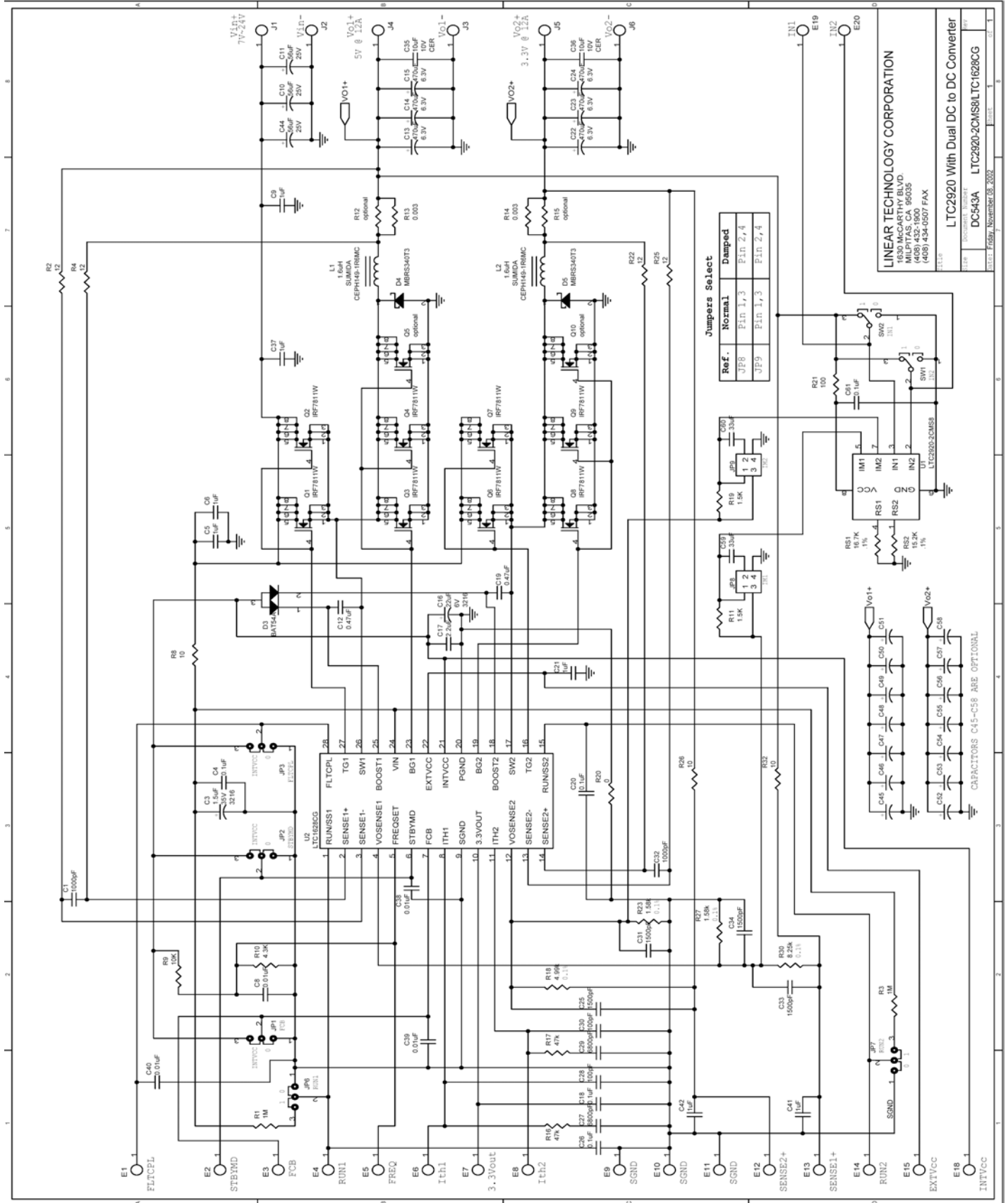

Figure 1. Proper Measurement Equipment setup

# QUICK START GUIDE FOR DEMONSTRATION CIRCUIT 543

## LTC2920 WITH DUAL DC TO DC CONVERTER



LINEAR TECHNOLOGY CORPORATION  
 100 N. BAY BLVD.  
 MILPITAS, CA 95035  
 (408) 432-1800  
 (408) 434-0507 FAX

LTC2920-2CMS80LTC1628CG  
 DC543A  
 November 08, 2002

## X-ON Electronics

Largest Supplier of Electrical and Electronic Components

*Click to view similar products for [Power Management IC Development Tools](#) category:*

*Click to view products by [Analog Devices](#) manufacturer:*

Other Similar products are found below :

[EVAL-ADM1168LQEBZ](#) [EVB-EP5348UI](#) [MIC23451-AAAYFL EV](#) [MIC5281YMME EV](#) [DA9063-EVAL](#) [ADP122-3.3-EVALZ](#) [ADP130-0.8-EVALZ](#) [ADP130-1.2-EVALZ](#) [ADP130-1.5-EVALZ](#) [ADP130-1.8-EVALZ](#) [ADP1714-3.3-EVALZ](#) [ADP1716-2.5-EVALZ](#) [ADP1740-1.5-EVALZ](#) [ADP1752-1.5-EVALZ](#) [ADP1828LC-EVALZ](#) [ADP1870-0.3-EVALZ](#) [ADP1871-0.6-EVALZ](#) [ADP1873-0.6-EVALZ](#) [ADP1874-0.3-EVALZ](#) [ADP1882-1.0-EVALZ](#) [ADP199CB-EVALZ](#) [ADP2102-1.25-EVALZ](#) [ADP2102-1.875EVALZ](#) [ADP2102-1.8-EVALZ](#) [ADP2102-2-EVALZ](#) [ADP2102-3-EVALZ](#) [ADP2102-4-EVALZ](#) [ADP2106-1.8-EVALZ](#) [ADP2147CB-110EVALZ](#) [AS3606-DB](#) [BQ24010EVM](#) [BQ24075TEVM](#) [BQ24155EVM](#) [BQ24157EVM-697](#) [BQ24160EVM-742](#) [BQ24296MEVM-655](#) [BQ25010EVM](#) [BQ3055EVM](#) [NCV891330PD50GEVB](#) [ISLUSBI2CKIT1Z](#) [LM2744EVAL](#) [LM2854EVAL](#) [LM3658SD-AEV/NOPB](#) [LM3658SDEV/NOPB](#) [LM3691TL-1.8EV/NOPB](#) [LM4510SDEV/NOPB](#) [LM5033SD-EVAL](#) [LP38512TS-1.8EV](#) [EVAL-ADM1186-1MBZ](#) [EVAL-ADM1186-2MBZ](#)