

Demo Circuit DC550A Quick Start Guide.

Introduction

Demo circuit DC550A demonstrates operation of the LT5514 IC, a DC-850MHz bandwidth ‘open loop’ transconductance amplifier with high impedance ‘open collector’ outputs. LT5514 consists of two identical amplifiers (Figure 1). Each amplifier has an enable pin (ENA and ENB). When both amplifiers are enabled, the LT5514 operates in “standard” (full power-high intercept point mode). The low power mode is selected when only one amplifier is enabled. Four programmable gain inputs provide a variable attenuation of up to 22.5 dB (relative to maximum gain) with 1.5 dB steps.

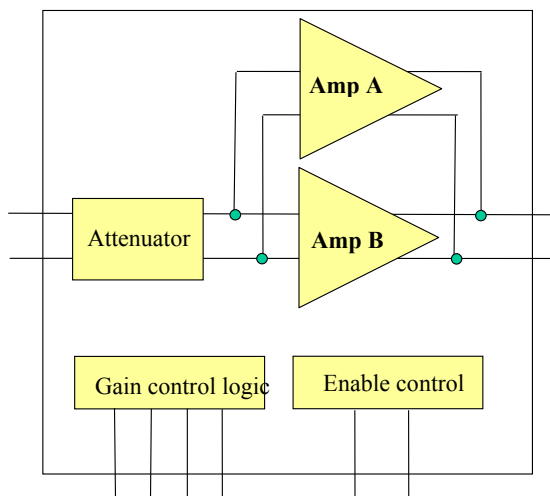

Figure 1. LT5514 Block Diagram

DEMO BOARD CONFIGURATIONS

DEMO BOARD RF INPUT:

TYPE	RF Input:	Input Impedance	1dB Freq. Range	Notes
A	SINGLE ENDED	50 ohms	3 – 300 MHz (Limited by RF input transformer)	1:2 RF Input Transformer
B	DIFFERENTIAL	100 ohms Differential	.1 – 600 MHz	Capacitive Coupled

Type A Input

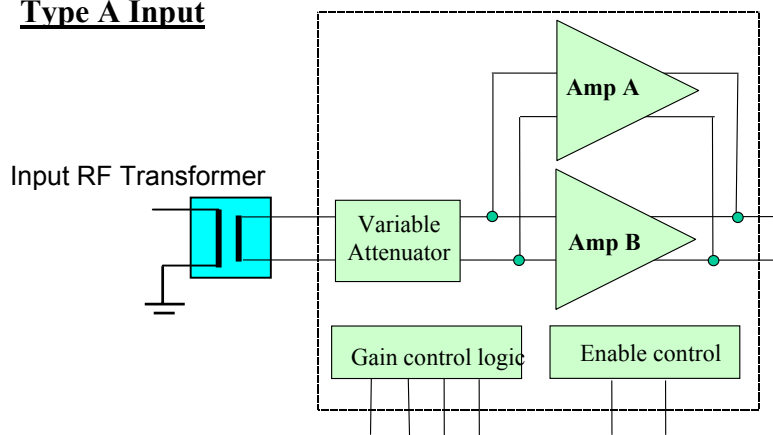

Type B Input

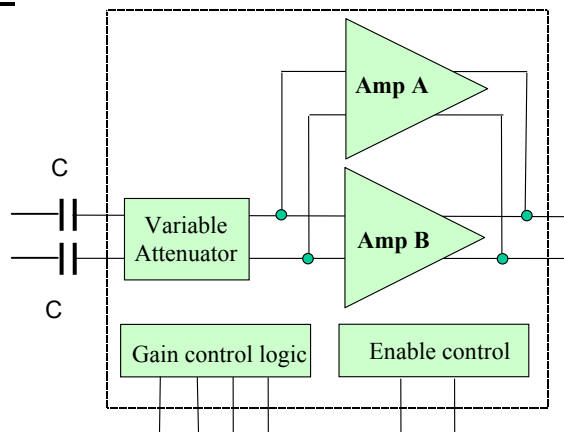

DEMO BOARD RF OUTPUT:

TYPE	RF Output:	Output Impedance	1dB Freq. Range	Max Gain	Notes
A	DIFFERENTIAL	100 ohms Differential	.1 – 600 MHz	27dB	Capacitive Coupled
B	SINGLE ENDED	50 ohms Single Ended	10 – 200 MHz (Limited by RF output transformer)	30dB	4:1 RF Output Transformer

Type A Output

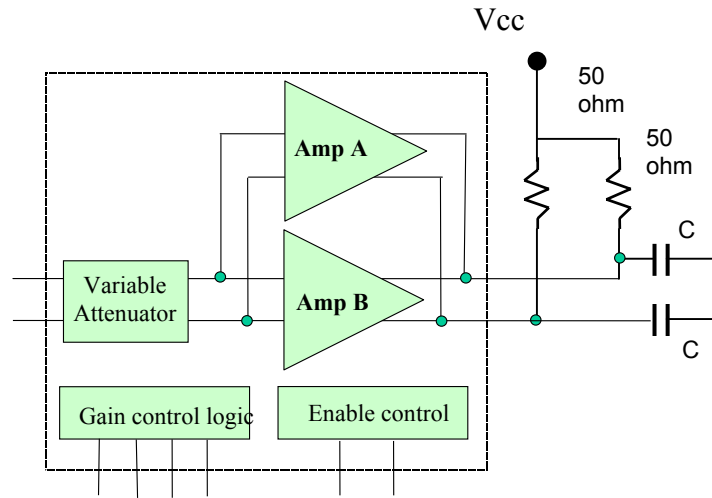

Type B Output

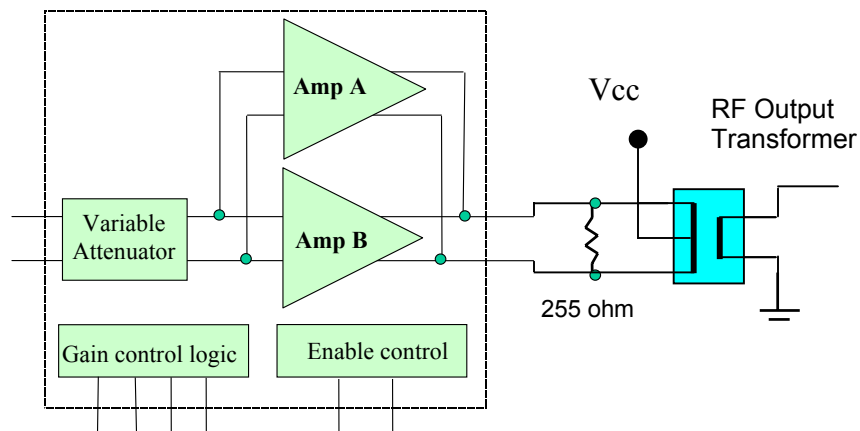

NOTE: LT5514 Demo circuits have been provided with Type A input configuration and with Type B output configuration, (RF transformers at input & output ports).

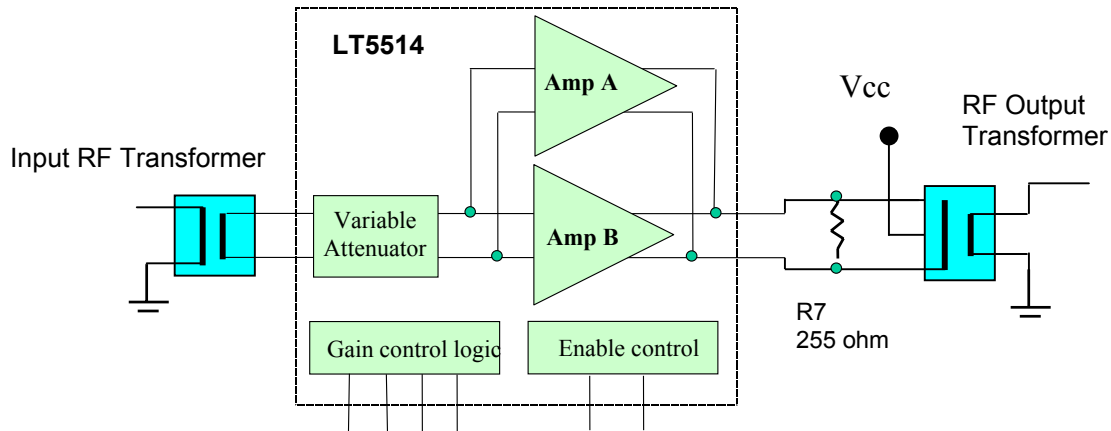

Figure 2. Block Diagram of the DC550A Demo Circuit with Type A Input and with Type B Output Configuration.

Please refer to the next page for actual electrical schematic of the LT5514 IC demo board DC550A with a Type A input and with a Type B output. Please note C2, C3, C7, C8, C11, C12 are not placed on PCB, as well as some Vcc bypass capacitors and D1 Zener diode.

Also enclosed, as a separate document, a complete demo board schematic and parts list, which support all possible configurations and modifications for the demo board.

Please note that with R7 (255 ohm, differential output shunt resistor), the circuit provides the best output return loss. For the best IM3 performance this resistor should be removed, resulting in about 3 dB IP3 improvements. This will also result in a small degradation of the return loss.

REVISION HISTORY				
ECO	REV	DESCRIPTION	DATE	APPROVED
	5	PROD	10/08/03	

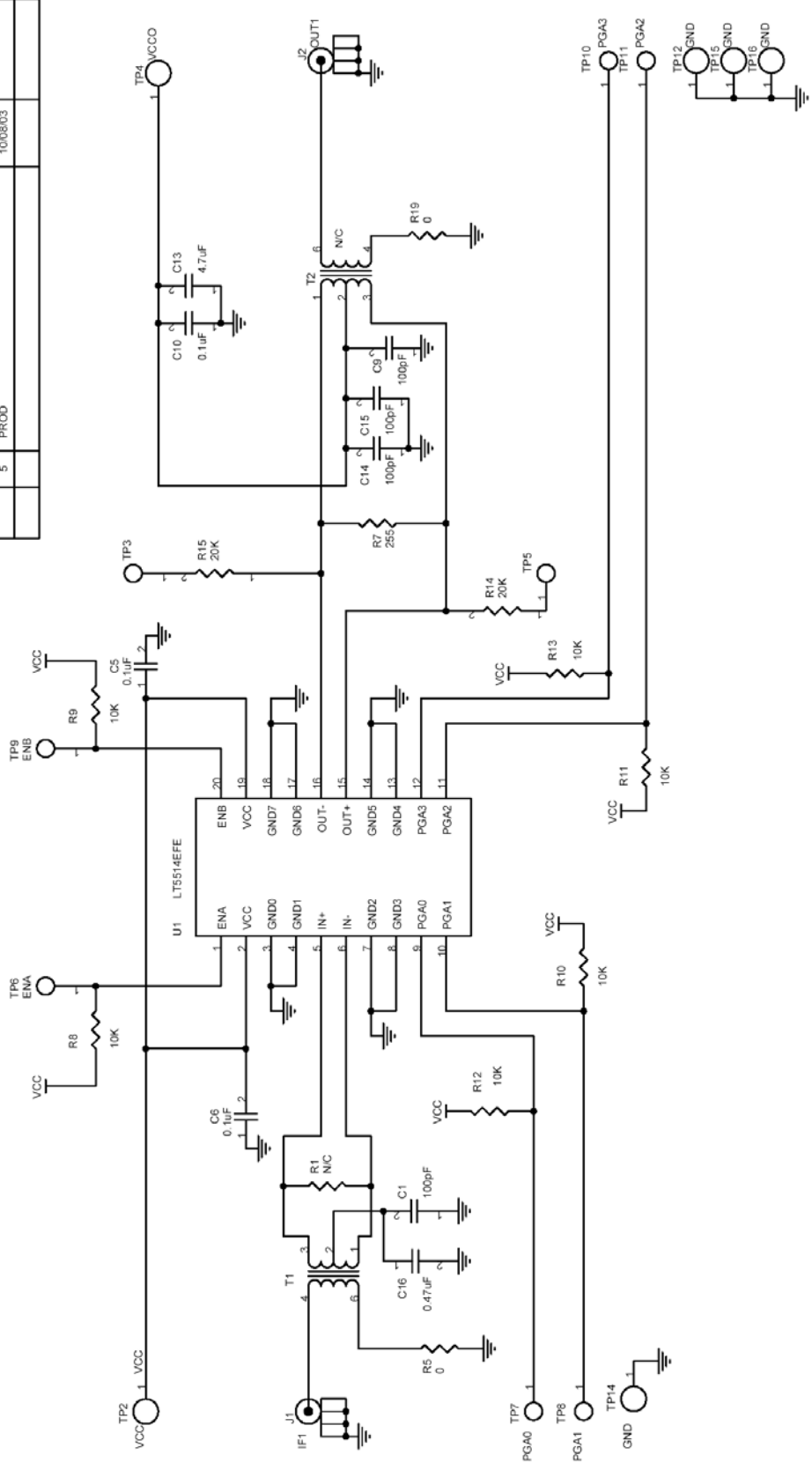

- NOTES: UNLESS OTHERWISE SPECIFIED,
1. ALL SWITCHES OFF (DOWN) FOR MAX GAIN
 2. ALL OTHER R & C ARE 10% OR BETTER.
 3. ALL C ARE RATED 16V OR BETTER.

This circuit is proprietary to Linear Technology and supplied for use with Linear Technology parts.
Customer Notice: Linear Technology has made a best effort to design a circuit that meets customer-supplied specifications; however, it remains the customer's responsibility to verify proper and reliable operation in the actual application. Component substitution and printed circuit board layout may significantly affect circuit performance or reliability. Contact Linear Applications Engineering for assistance.

UNLESS OTHERWISE SPECIFIED DIMENSIONS ARE IN INCHES TOLERANCES ON ANGLE ... 2 PLACES ... 3 PLACES ... INTERPRET DIM AND TOL PER ASME Y14.5M-1994		CONTRACT NO.	DATE
THIRD ANGLE PROJECTION		APPROVALS	DATE
DO NOT SCALE DRAWING		DRAWN: MEI	06-24-02
		CHECKED	TITLE
		APPROVED	SCH, LT5514EFE IF AMP/ADC DRIVER AS ASSEMBLED WITH TYPE A INPUT AND TYPE B OUTPUT
		ENGINEER	SIZE
		DESIGNER	CAGE CODE
			DWG NO DC550A
			REV 5
		Thursday, June 03, 2004	SCALE NONE
		FILENAME550A-5.DSN	SHEET 1 OF 1



1630 McCarthy Blvd.
 Milpitas, CA 95035
 Phone: (408)432-1900
 Fax: (408)434-0607

Demo Circuit Settings (refer to demo board schematic):

Table 1. Modes of Operation

	Modes	EN_A	EN_B	Amp A	Amp B	LT5514 State
1	Standard (Full Power)	HIGH	HIGH	ON	ON	Enable amp A and amp B
2	Low Power A	HIGH	LOW	ON	OFF	Enable amp A
3	Low Power B	LOW	HIGH	OFF	ON	Enable amp B
4	Shutdown	LOW	LOW	OFF	OFF	Sleep, both amps disabled

Note: Enable inputs ENA and ENB can be controlled externally using turret pins ENA and ENB located at the top of the demo board. HIGH logic levels are provided to both Enable inputs by default (because of the pull-up resistors on the control lines).

Table 2. Gain Programming Table

	ATTENUATION Relative to MAX GAIN	PGA0	PGA1	PGA2	PGA3
1	0 dB	HIGH	HIGH	HIGH	HIGH
2	-1.5 dB	LOW	HIGH	HIGH	HIGH
3	-3.0 dB	HIGH	LOW	HIGH	HIGH
4	-4.5 dB	LOW	LOW	HIGH	HIGH
5	-6.0 dB	HIGH	HIGH	LOW	HIGH
6	-7.5 dB	LOW	HIGH	LOW	HIGH
7	-9.0 dB	HIGH	LOW	LOW	HIGH
8	-10.5 dB	LOW	LOW	LOW	HIGH
9	-12.0 dB	HIGH	HIGH	HIGH	LOW
10	-13.5 dB	LOW	HIGH	HIGH	LOW
11	-15.0 dB	HIGH	LOW	HIGH	LOW
12	-16.5 dB	LOW	LOW	HIGH	LOW
13	-18.0 dB	HIGH	HIGH	LOW	LOW
14	-19.5 dB	LOW	HIGH	LOW	LOW
15	-21.0 dB	HIGH	LOW	LOW	LOW
16	-22.5 dB	LOW	LOW	LOW	LOW

Note: Gain control lines PGA0, PGA1, PGA2 and PGA3 can be controlled externally using pins PGA0, PGA1, PGA2 and PGA3 located at the bottom of the demo board. HIGH logic levels are provided to all four gain control inputs by default (pull-up resistors on the control inputs).

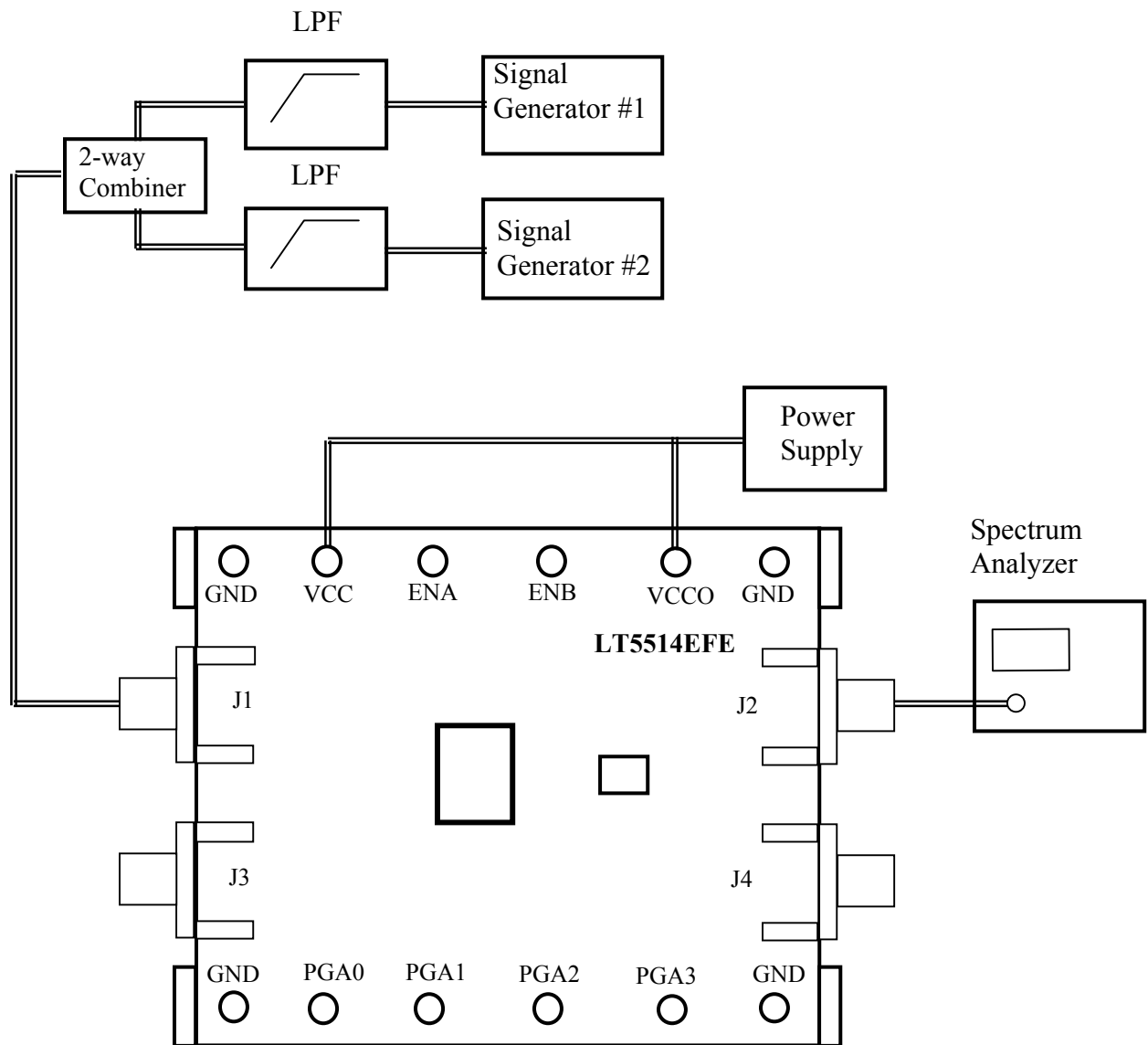

Figure 3. Test & Measurement Setup for Single Ended Input & Single Ended Output Demo Circuit.

DC Power Consumption Measurements:

Connect test equipment and power supply to the demo board as shown in Figure 3.

Set power supply to +5.0V.

NOTE: For a demo board with a type “A” output (with 50 ohm pull-up resistors) a separate 7.5V power supply should be connected to Vcco for measurements with output signal swing of 2.0V peak to peak or higher. This will result in 5.0VDC at the output (open collector) pins, because of the voltage drop across the 50 ohm output pull-up resistors.

Shutdown Mode:

Set ENA and ENB to Logic LOW state.

Measure VCC and VCCO shutdown current.

NOTE: Shutdown current should be 1 to 2mA due to external 10k ohm pull-up resistors (R8 and R9).

Standard Operation Mode:

Set ENA and ENB to Logic HIGH state.

Measure VCC and VCCO operating current.

Gain, Frequency Response and OIP3 Measurements:

- 1) Connect test equipment and power supply to the demo board as shown in Figure 3.
- 2) Set ENA and ENB to Logic HIGH state (Refer to Table 1 and Table 2). The IC is in Standard Operation Mode (both amps are ON) and the amplifier has maximum gain.
- 3) Perform single CW tone frequency sweep (100 KHz to 600 MHz) and measure gain and frequency response. NOTE: For a demo board with a type “A” output (with 50 ohm pull-up resistors) external 180° combiner should be used. Measurements can be also done using one output. In this case the other output should be terminated externally. One-output measurements have no common mode rejection and will show higher output noise.
- 4) Apply two input CW tones and perform two-tone output IM3 product measurements at different output power levels from 0 dBm to +10 dBm (per each tone).
NOTE: For a demo board with a type “A” output (with 50 ohm pull-up resistors) an external 180° combiner should be used. Single output measurements will show an elevated noise floor. For single output measurements, the second output should be terminated externally with 50 ohm load.

Notes for Two Tone Measurements:

1. High quality signal generators (with low level of output harmonics and reverse power protection) should be used. Low pass filters should be employed at the signal generator outputs to minimize higher order harmonics to -90 dBc or better. Attenuator pads at the signal generator outputs will also help to minimize reverse power problems.
2. A high sensitivity/high dynamic range spectrum analyzer should be used. Care must be taken to operate the spectrum analyzer in linear mode to avoid additional IM distortion products produced by the instrument itself. It is advisable to use a narrow bandpass filter at the spectrum analyzer input to select IM products and attenuate main tones. In this case, a 10 to 20 dB attenuator should be placed between the LT5514 output and the BPF input to provide broadband matching.

Additional application notes (refer to the complete demo circuit schematic):

- In a type “B” output (demo circuit with output RF transformer), resistor R7 is 255 ohm. This provides the best output return loss. For best IM performance this resistor should be removed. This will result in a 5dB IM3 performance improvement.
- R19 is a zero ohm jumper. R19 can be removed if differential output is desired.
- Output transformer T2 can be removed and pull-up resistors (50 ohm) can be placed at R20 and R21 locations at the topside of the demo board. Also, pull-up inductors (820 nH) can be placed at R20 and R21 locations as well. This will result in higher output impedance. For proper impedance matching 50 ohm resistors can be connected in parallel with pull-up inductors. Coupling capacitors (not shown on the demo board schematic) can be placed instead of the output transformer T2, connecting output pins 15 and 16 to the output SMA connectors J2 and J4.

LTC CONFIDENTIAL - For Customer Use Only

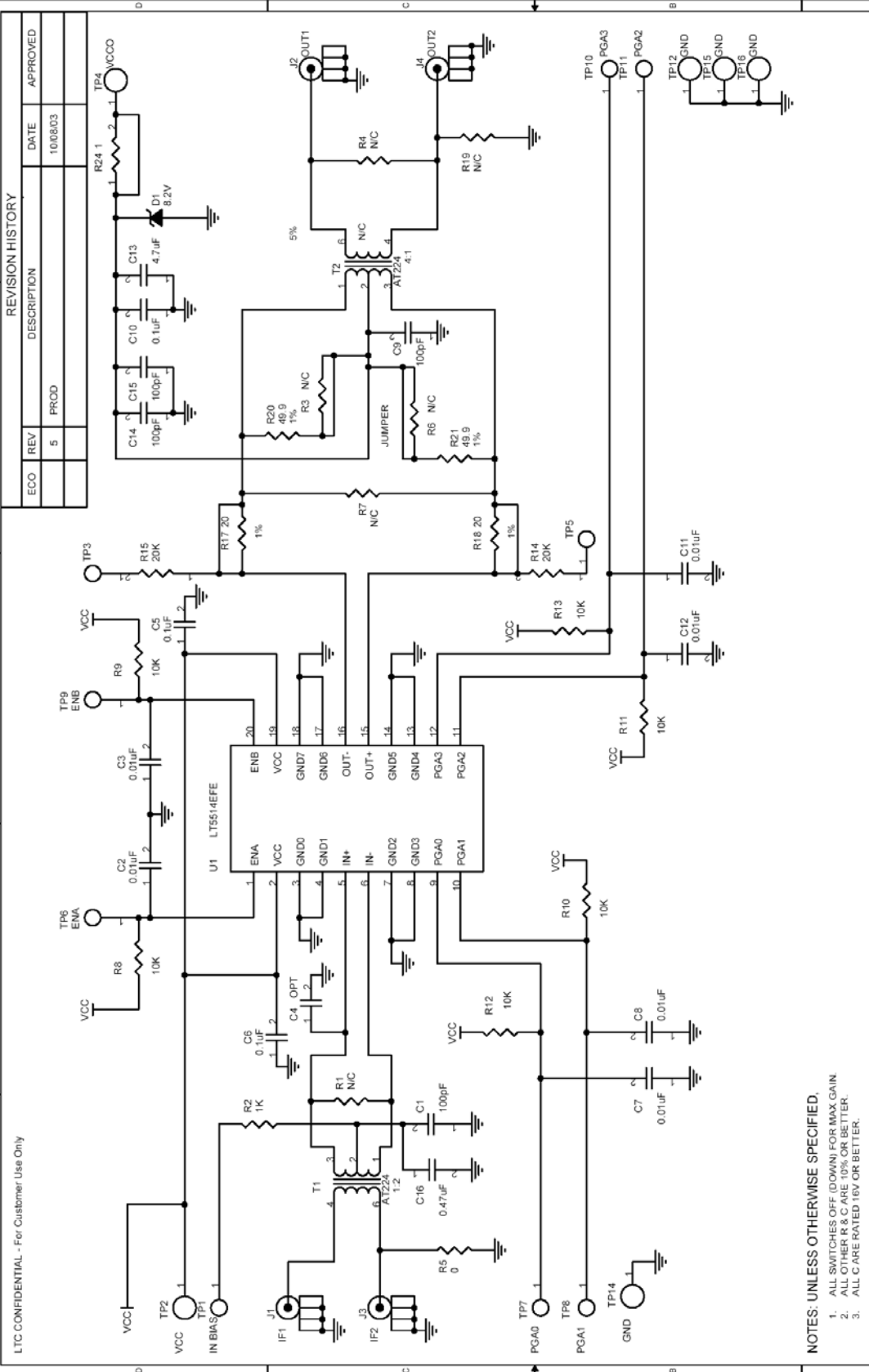

- NOTES: UNLESS OTHERWISE SPECIFIED,**
1. ALL SWITCHES OFF (DOWN) FOR MAX. GAIN
 2. ALL OTHER R & C ARE 10% OR BETTER.
 3. ALL C ARE RATED 16V OR BETTER.

REVISION HISTORY				
ECO	REV	DESCRIPTION	DATE	APPROVED
	5	PROD	10/08/03	

		CONTRACT NO. _____ APPROVALS _____ DATE 06-24-02 DRAWN MEI _____ CHECKED _____ APPROVED _____ ENGINEER _____ DESIGNER _____	
		TITLE SCH, LT5514EFE IF AMP/ADC DRIVER	
UNLESS OTHERWISE SPECIFIED DIMENSIONS ARE IN INCHES TOLERANCE ON ANGLE ... 2 PLACES ... 3 PLACES ... INTERPRET DIM AND TOL PER ASME Y14.5M-1994		SCALE NONE FILENAME DC550A-5.DSN SHEET 1 OF 1	
DO NOT SCALE DRAWING		THIRDS ANGLE PROJECTION	

This circuit is proprietary to Linear Technology and supplied for use with Linear Technology parts.
Customer Notice: Linear Technology has made a best effort to design a circuit that meets customer-supplied specifications; however, it remains the customer's responsibility to verify proper and reliable operation in the actual application. Component substitution and printed circuit board layout may significantly affect circuit performance or reliability. Contact Linear Applications Engineering for assistance.

X-ON Electronics

Largest Supplier of Electrical and Electronic Components

Click to view similar products for [Amplifier IC Development Tools](#) category:

Click to view products by [Analog Devices](#) manufacturer:

Other Similar products are found below :

[EVAL-ADCMP566BCPZ](#) [EVAL-ADCMP606BKSZ](#) [AD8013AR-14-EBZ](#) [AD8033AKS-EBZ](#) [AD8044AR-EBZ](#) [AD8225-EVALZ](#)
[ADA4859-3ACP-EBZ](#) [ADA4862-3YR-EBZ](#) [DEM-OPA-SO-2B](#) [AD744JR-EBZ](#) [AD8023AR-EBZ](#) [AD8030ARJ-EBZ](#) [AD8040ARU-EBZ](#)
[AD8073JR-EBZ](#) [AD813AR-14-EBZ](#) [AD848JR-EBZ](#) [ADA4858-3ACP-EBZ](#) [ADA4922-1ACP-EBZ](#) [551600075-001/NOPB](#) [DEM-OPA-SO-](#)
[2E](#) [THS7374EVM](#) [EVAL-ADCMP553BRMZ](#) [EVAL-ADCMP608BKSZ](#) [MIOP 42109](#) [EVAL-ADCMP609BRMZ](#) [MAX9928EVKIT+](#)
[MAX9636EVKIT+](#) [MAX9611EVKIT](#) [MAX9937EVKIT+](#) [MAX9934TEVKIT+](#) [MAX44290EVKIT#](#) [MAX2644EVKIT](#) [MAX4073EVKIT+](#)
[DEM-OPA-SO-2C](#) [MAX2643EVKIT](#) [ISL28158EVAL1Z](#) [MAX40003EVKIT#](#) [MAX2473EVKIT](#) [MAX2472EVKIT](#) [MAX4223EVKIT](#)
[MAX9700BEVKIT](#) [MADL-011014-001SMB](#) [DC1685A](#) [DEM-OPA-SO-2D](#) [MAX2670EVKIT#](#) [DEM-OPA-SO-1E](#) [AD8137YCP-EBZ](#)
[EVAL-ADA4523-1ARMZ](#) [MAX44242EVKIT#](#) [EVAL-LT5401_32FDAZ](#)