

# QUICK START GUIDE FOR DEMONSTRATION CIRCUIT 558A

## 3-PHASE HIGH EFFICIENCY DC/DC CONVERTER

### LTC3731CUH

## DESCRIPTION

Demonstration circuit 558 is a high current step-down PolyPhase™ converter featuring the LTC3731 three-phase synchronous buck controller. The demo circuit input voltage is from 5V to 14V and output is 1.5V/60A. To minimize the supply footprint size and improve the thermal performance, the 5mm x 5mm QFN package LTC3731CUH controller is used. High density power

components are used and the power components is within a 0.8 x 2.3 inch<sup>2</sup> footprint area.

**Design files for this circuit board are available. Call the LTC factory.**

**Table 1. Performance Summary (T<sub>A</sub> = 25°C)**

PARAMETER	CONDITION	VALUE
Minimum Input Voltage		5V
Maximum Input Voltage		14V
V <sub>OUT</sub>	I <sub>OUT</sub> = 0A to 60A	1.5V±1%
Maximum Continuous Load Current (ΔT <sub>MAX</sub> =50 °C)	Without heat sink, without cooling fan	50A
	Without heat sink, with cooling fan (300LFM)	60A
	With heat sink, with cooling fan (300LFM)	70A
Nominal Switching Frequency	Set by resistor divider on demo boards	400kHz
Typical Efficiency	V <sub>IN</sub> = 12V, V <sub>OUT</sub> = 1.5V, I <sub>OUT</sub> = 60A, using external +5V for IC bias	82.4%

## QUICK START PROCEDURE

Demonstration circuit 558 is easy to set up to evaluate the performance of the LTC3731CUH. Refer to Figure 1 for proper measurement equipment setup and follow the procedure below:

1. Preset the following jumpers on the demo board: FCB-CCM, FREQ-INT PROG, 5V SEL-INT, DLC BIAS-OFF and DLC-OFF. With above jumpers setup, the supply is running at about 400kHz phase frequency, and using the on board +5V bias supply.
2. Preset the voltage of the input power supply to be 12V. Preset the current limit of input power supply to be large than 25A. With power off, connect the input power supply to Vin and GND.
3. Connect the electronic load to Vout+ and Vout-. Pre-set the load current to be 0A.
4. Turn on the power at the input.
5. Check for the proper output voltages at no load and full load. Vout = 1.485V to 1.515V. Cooling fan is needed if the load current is higher than 50A.
6. Adjust the loads and input voltage within the operating range and observe the output voltage regulation, efficiency and other parameters.
7. (Optional) DC558A board has optional +5V bias input pins for better efficiency at 12V supply input voltage. To use the external 5V bias voltage, set jumper 5V SEL-EXT. Apply the supply input voltage before applying the +5V bias voltage.

# QUICK START GUIDE FOR DEMONSTRATION CIRCUIT 558A

## 3-PHASE HIGH EFFICIENCY DC/DC CONVERTER

8. (Optional) To perform the load transient test, set jumpers DLC BIAS-ON and DLC-ON. Use coaxial cables to connect LOAD STEP and Vout+ coaxial out-

puts to oscilloscope inputs. Adjust R34 and R38 for desired load current step and rising slope. Adjust R33 for desired load current falling slope.

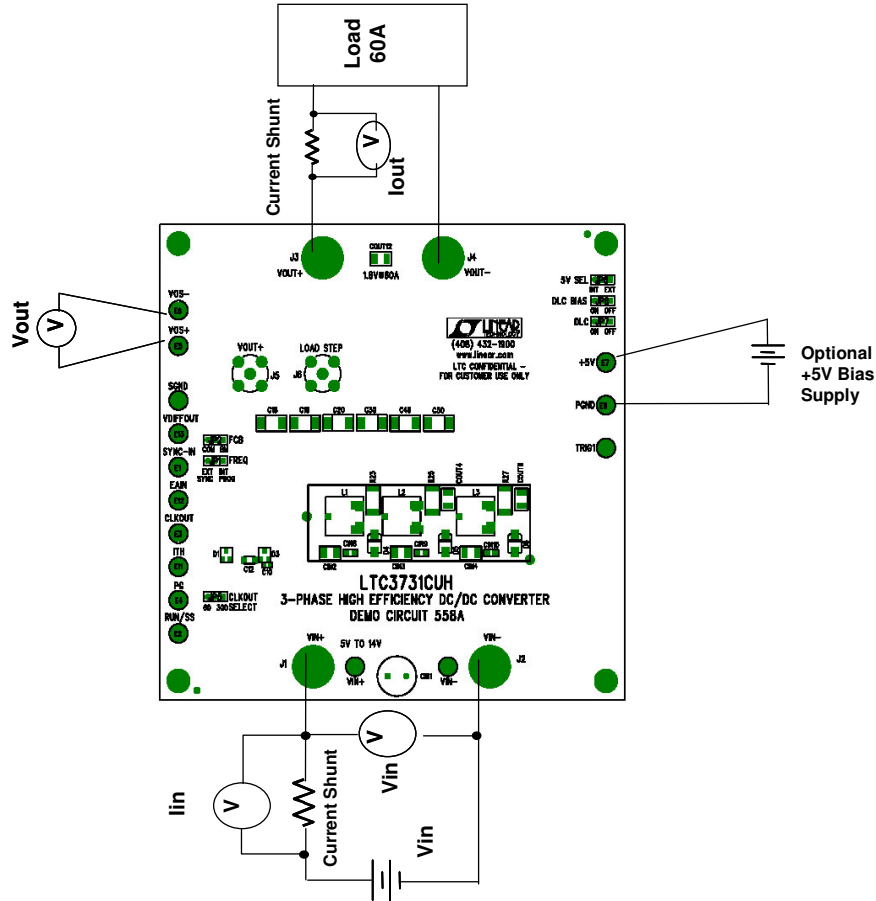

Figure 1. Proper Measurement Equipment Setup

## X-ON Electronics

Largest Supplier of Electrical and Electronic Components

*Click to view similar products for [Power Management IC Development Tools](#) category:*

*Click to view products by [Analog Devices](#) manufacturer:*

Other Similar products are found below :

[EVAL-ADM1168LQEBZ](#) [EVB-EP5348UI](#) [MIC23451-AAAYFL EV](#) [MIC5281YMME EV](#) [DA9063-EVAL](#) [ADP122-3.3-EVALZ](#) [ADP130-0.8-EVALZ](#) [ADP130-1.2-EVALZ](#) [ADP130-1.5-EVALZ](#) [ADP130-1.8-EVALZ](#) [ADP1714-3.3-EVALZ](#) [ADP1716-2.5-EVALZ](#) [ADP1740-1.5-EVALZ](#) [ADP1752-1.5-EVALZ](#) [ADP1828LC-EVALZ](#) [ADP1870-0.3-EVALZ](#) [ADP1871-0.6-EVALZ](#) [ADP1873-0.6-EVALZ](#) [ADP1874-0.3-EVALZ](#) [ADP1882-1.0-EVALZ](#) [ADP199CB-EVALZ](#) [ADP2102-1.25-EVALZ](#) [ADP2102-1.875EVALZ](#) [ADP2102-1.8-EVALZ](#) [ADP2102-2-EVALZ](#) [ADP2102-3-EVALZ](#) [ADP2102-4-EVALZ](#) [ADP2106-1.8-EVALZ](#) [ADP2147CB-110EVALZ](#) [AS3606-DB](#) [BQ24010EVM](#) [BQ24075TEVM](#) [BQ24155EVM](#) [BQ24157EVM-697](#) [BQ24160EVM-742](#) [BQ24296MEVM-655](#) [BQ25010EVM](#) [BQ3055EVM](#) [NCV891330PD50GEVB](#) [ISLUSBI2CKIT1Z](#) [LM2744EVAL](#) [LM2854EVAL](#) [LM3658SD-AEV/NOPB](#) [LM3658SDEV/NOPB](#) [LM3691TL-1.8EV/NOPB](#) [LM4510SDEV/NOPB](#) [LM5033SD-EVAL](#) [LP38512TS-1.8EV](#) [EVAL-ADM1186-1MBZ](#) [EVAL-ADM1186-2MBZ](#)