

# QUICK START GUIDE FOR DEMONSTRATION CIRCUIT 563

## SINGLE AND DUAL MARGINING CONTROLLER

LTC2920-1CS5  
LTC2920-2CMS8

## DESCRIPTION

Demonstration circuit 563 contains two separate circuits: a (single channel) LTC2920-1 and a (dual channel) LTC2920-2 Power Supply Margining Controllers. This board is meant to be connected to up to three power supplies and demonstrates the voltage margining capabilities of the LTC2920. The board is scribed for easy separation of the two circuits if desired. Each circuit contains a Margining Controller, bypass

capacitor, and pads for external connections. There are also component locations for adding 0805 resistors. **These resistors are specific to each application and must be installed to demonstrate Voltage Margining.**

**Design files for this circuit board are available. Call the LTC factory.**

## QUICK START PROCEDURE

Referring to Figure 1, the Vcc1 and Gnd1 pins provide the power and ground connections for the LTC2920-1 (single). The Vcc2 and Gnd2 pins provide the power and ground connections for the LTC2920-2 (dual). The Vcc voltage can generally be varied between 2.2V and 6.0V. Vcc must be at least 0.6 volts higher than the voltage at the Im pin. See the LTC2920 Data Sheet for other design considerations on minimum Vcc voltage and Vcc filtering. Be sure to connect the ground pin(s) to the same ground as the power supply(s) being margined.

For margining power supplies with external feedback resistors, the Im pins should be connected to the power supply feedback node. For margining power supplies using trim pins, the Im pin should be connected to the power supply trim pin.

The I<sub>margin</sub> current sourced or sunk from each Im pin is individually programmed by its respective on board R<sub>set</sub> resistor. For the LTC2920-1 circuit, there are two possible locations for the R<sub>set</sub> resistor. Placing the R<sub>set</sub> resistor in the 'RLOW' position will program the I<sub>margin</sub> current at  $1V / R_{set}$ . Placing the R<sub>set</sub> resistor in the 'RHI' position will program the I<sub>margin</sub> current at  $30 * 1V / R_{set}$ . See the LTC2920 Data Sheet for the specification limits of the high and low current ranges. On the LTC2920-2 circuit, there

are two positions for each of the two R<sub>set</sub> resistors. The 'R1L' and 'R2L' positions are similar to the 'RLOW' position described above. The 'R1H' and 'R2H' positions are similar to the 'RHI' position described above.

The In pins can be connected to a system controller that has a 3-state output, or manually connected as shown. When using a 3-state output to control the In pin, placing the (3-state) output in the high-Z state will 'float' the In pin, and cause the controlled Im pin to be in a high impedance state. Raising an In pin above 2.0 Volts will cause its respective Im pin to sink current. Lowering an In pin below 0.6 Volts will cause its respective Im pin to source current. See the LTC2920 Data Sheet for details. The In pins may also be controlled manually by connecting them to Vcc, ground, or left floating.

After calculating and inserting the R<sub>set</sub> resistor(s) as described above, place the DC563 board as close as possible to the power supply(ies) being margined. The ground, Vcc, and Im pins should be connected with the shortest practical wires.

With power applied, the power supply output(s) should be at their nominal values with the In pin(s)

# QUICK START GUIDE FOR DEMONSTRATION CIRCUIT 563

## SINGLE AND DUAL MARGINING CONTROLLER

floating. Raising the In pin(s) above 2.0 V will cause the power supply output voltage to increase by the desired margin voltage. Lowering the In pin(s) below 0.6 V will cause the power supply output voltage to decrease by the desired margin voltage. **When connected to ‘trim’ pins on DC to DC modules, the polarity of the voltage margining may be inverted.**

If the LTC2920 Vcc pin is connected to power supplies that are compensated to be only ‘marginally stable,’ oscillations may be observed. If oscillations are observed while margining a power supply, connect the Vcc pin to the power supply using an axial lead resistor instead of a wire. See the LTC2920 Data Sheet for calculating the value of this resistor.

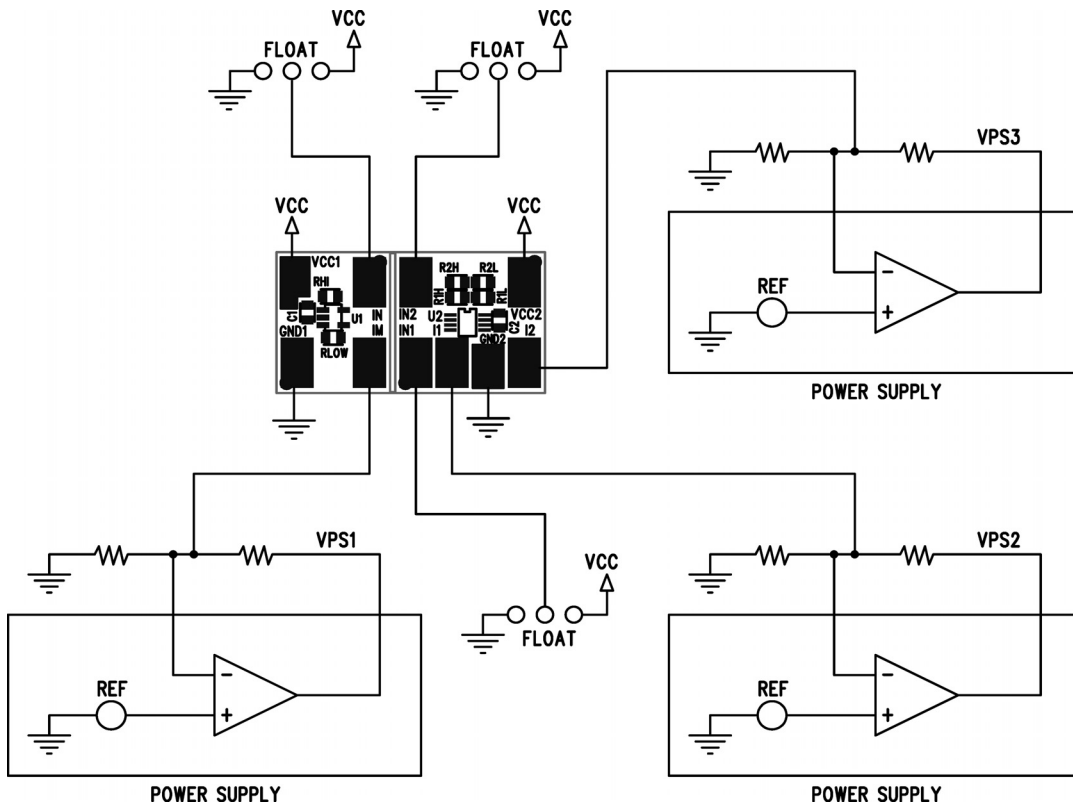
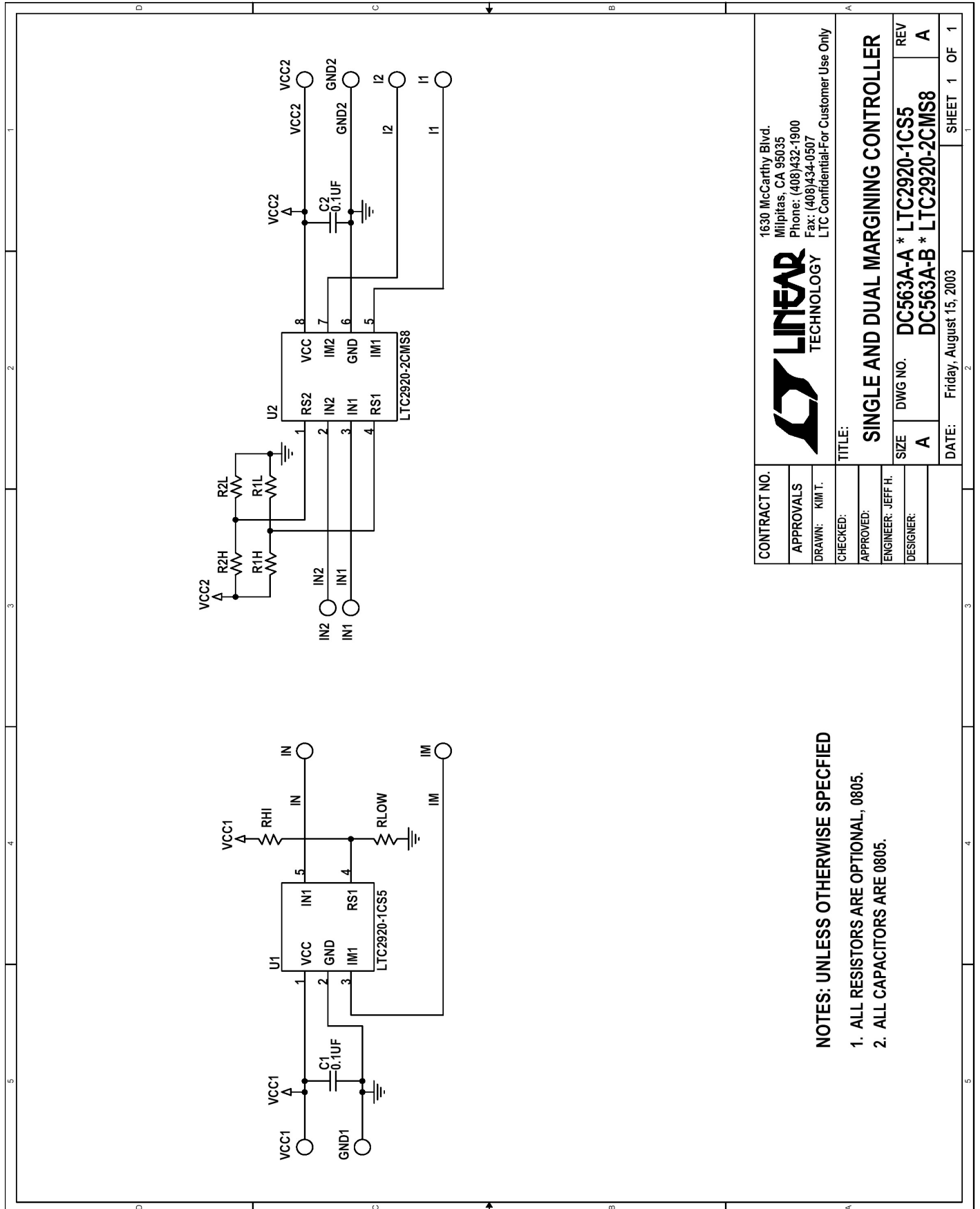

Figure 1. Proper Measurement Equipment Setup

# QUICK START GUIDE FOR DEMONSTRATION CIRCUIT 563

## SINGLE AND DUAL MARGINING CONTROLLER



**NOTES: UNLESS OTHERWISE SPECIFIED**

1. ALL RESISTORS ARE OPTIONAL, 0805.
2. ALL CAPACITORS ARE 0805.

<b>CONTRACT NO.</b>		1630 McCarthy Blvd. Milpitas, CA 95035 Phone: (408)432-1900 Fax: (408)434-0507 LTC Confidential-For Customer Use Only	
<b>APPROVALS</b>		<b>LINEAR TECHNOLOGY</b>	
<b>DRAWN: KIM T.</b>		<b>TITLE:</b>	
<b>CHECKED:</b>		<b>SINGLE AND DUAL MARGINING CONTROLLER</b>	
<b>APPROVED:</b>		<b>SIZE DWG NO. DC563A-A * LTC2920-1CS5</b>	
<b>ENGINEER: JEFF H.</b>		<b>REV DC563A-B * LTC2920-2CMS8</b>	
<b>DESIGNER:</b>		<b>A</b>	
<b>DATE: Friday, August 15, 2003</b>		<b>SHEET 1 OF 1</b>	

## X-ON Electronics

Largest Supplier of Electrical and Electronic Components

*Click to view similar products for [Power Management IC Development Tools](#) category:*

*Click to view products by [Analog Devices](#) manufacturer:*

Other Similar products are found below :

[EVAL-ADM1168LQEBZ](#) [EVB-EP5348UI](#) [MIC23451-AAAYFL EV](#) [MIC5281YMME EV](#) [DA9063-EVAL](#) [ADP122-3.3-EVALZ](#) [ADP130-0.8-EVALZ](#) [ADP130-1.2-EVALZ](#) [ADP130-1.5-EVALZ](#) [ADP130-1.8-EVALZ](#) [ADP1714-3.3-EVALZ](#) [ADP1716-2.5-EVALZ](#) [ADP1740-1.5-EVALZ](#) [ADP1752-1.5-EVALZ](#) [ADP1828LC-EVALZ](#) [ADP1870-0.3-EVALZ](#) [ADP1871-0.6-EVALZ](#) [ADP1873-0.6-EVALZ](#) [ADP1874-0.3-EVALZ](#) [ADP1882-1.0-EVALZ](#) [ADP199CB-EVALZ](#) [ADP2102-1.25-EVALZ](#) [ADP2102-1.875EVALZ](#) [ADP2102-1.8-EVALZ](#) [ADP2102-2-EVALZ](#) [ADP2102-3-EVALZ](#) [ADP2102-4-EVALZ](#) [ADP2106-1.8-EVALZ](#) [ADP2147CB-110EVALZ](#) [AS3606-DB](#) [BQ24010EVM](#) [BQ24075TEVM](#) [BQ24155EVM](#) [BQ24157EVM-697](#) [BQ24160EVM-742](#) [BQ24296MEVM-655](#) [BQ25010EVM](#) [BQ3055EVM](#) [NCV891330PD50GEVB](#) [ISLUSBI2CKIT1Z](#) [LM2744EVAL](#) [LM2854EVAL](#) [LM3658SD-AEV/NOPB](#) [LM3658SDEV/NOPB](#) [LM3691TL-1.8EV/NOPB](#) [LM4510SDEV/NOPB](#) [LM5033SD-EVAL](#) [LP38512TS-1.8EV](#) [EVAL-ADM1186-1MBZ](#) [EVAL-ADM1186-2MBZ](#)