

QUICK START GUIDE FOR DEMONSTRATION CIRCUIT 620 HIGH CURRENT QUAD OUTPUT SWITCHING REGULATORS FOR TFT-LCD PANELS

LT1943

DESCRIPTION

Demonstration circuit 620 is a quad output power supply intended for use in large TFT-LCD panels. The circuit features the LT[®]1943 high current quad-output switching regulator and generates a 3.3V logic supply along with the triple output supply required for the TFT-LCD panels. With an input voltage range of 8V to 20V, a step down regulator provides 3.3V V_{LOGIC} with up to 2A current; a high power SEPIC converter, a lower power boost converter and an inverting converter provide three independent output voltages AV_{DD} , V_{ON} and V_{OFF} required by the LCD panels. A high side PNP provides delayed turn on of the V_{ON} signal and can source up to 30mA at 30V.

All four switchers are synchronized to the internal 1.2MHz clock, allowing the use of low profile inductors and ceramic capacitors. They all have soft-start to limit start-up inrush current.

Long wires run from input sources (such as wall adaptors) can cause large voltage spikes during initial plug-in. C17 is installed on DC620 to damp the possible voltage spikes. C17 is not required for applications when input source is close to the regulator. Please refer to Application Note 88 for details.

Design files for this circuit board are available. Call the LTC factory.

LT is a registered trademark of Linear Technology Corporation

Table 1. Performance Summary ($T_A = 25^\circ\text{C}$ unless otherwise noted)

PARAMETER	CONDITION	VALUE
Minimum Input Voltage	-40°C to 85°C	8V
Maximum Input Voltage	-40°C to 85°C	20V
Output Voltage V_{LOGIC}	$V_{\text{IN}} = 8\text{V to } 20\text{V}$, $I_{\text{OUT}} = 0\text{A to } 2\text{A}$	3.3V $\pm 3\%$
Maximum Output Current at V_{LOGIC}	$V_{\text{IN}} = 8\text{V to } 20\text{V}$ (Note 1)	2A
Typical Output Ripple V_{LOGIC}	$V_{\text{IN}} = 12\text{V}$, load at $V_{\text{LOGIC}} = 2\text{A}$ (20MHz BW)	23mV _{P-P}
Typical Output Ripple AV_{DD}	$V_{\text{IN}} = 12\text{V}$, load at $AV_{\text{DD}} = 500\text{mA}$ (20MHz BW)	64mV _{P-P}
Typical Switching Frequency		1.2MHz
On/Off Control	Logic Low Voltage-Off, -40°C to 85°C	0.4V MAX
	Logic High Voltage-On	2.4V MIN

Note 1: 2A maximum output current is guaranteed when V_{OFF} is unloaded. Since V_{OFF} is supplied from V_{LOGIC} , the load at V_{OFF} reduces the available current at V_{LOGIC} . More output current is available at higher input voltage. Please refer to the LT1943 data sheet for output current vs. input voltage curve.

QUICK START PROCEDURE

Demonstration circuit 620 is easy to set up to evaluate the performance of the LT1943. Refer to Figure 1 for proper measurement equipment setup and follow the procedure below:

NOTE: When measuring the input or output voltage ripple, care must be taken to avoid a long ground lead on the oscilloscope probe. Measure the input or output voltage ripple by touching the

QUICK START GUIDE FOR DEMONSTRATION CIRCUIT 620

HIGH CURRENT QUAD OUTPUT SWITCHING REGULATORS FOR TFT-LCD PANELS

- probe tip directly across the V_{IN} or V_{OUT} and GND terminals. See Figure 2 for proper scope probe technique.
1. Make sure the input voltage does not exceed 20V. With power off, connect the input power supply to V_{IN} and GND.
 2. Turn on the power at the input.
 3. Check for the proper output voltages. If there is no output, temporarily disconnect the load to make sure that the load is not set too high.
 4. Once the proper output voltages are established, adjust the loads within the operating range and observe the output voltage regulation, ripple voltage, efficiency and other parameters.

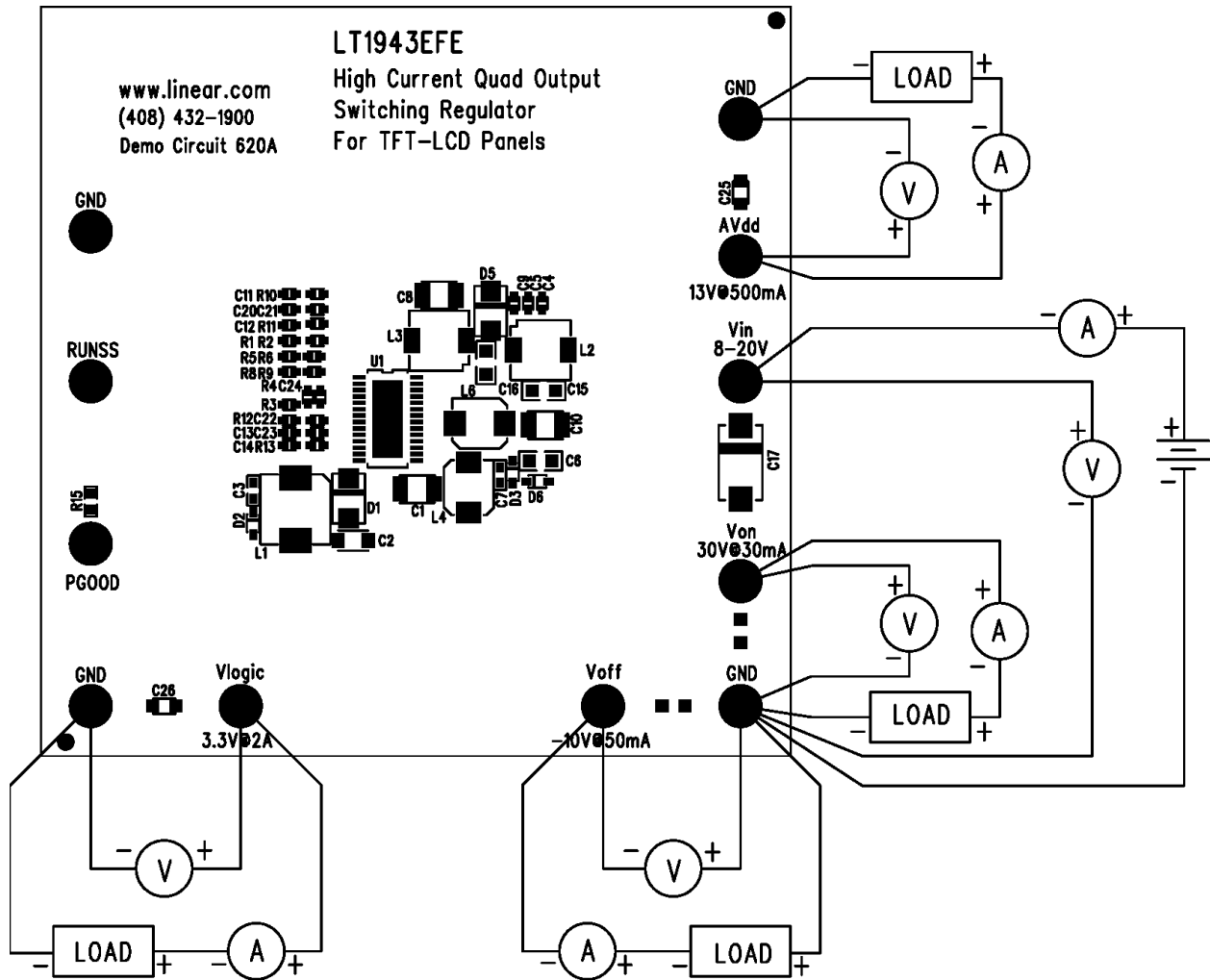

Figure 1. Proper Measurement Equipment Setup

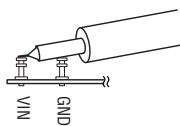
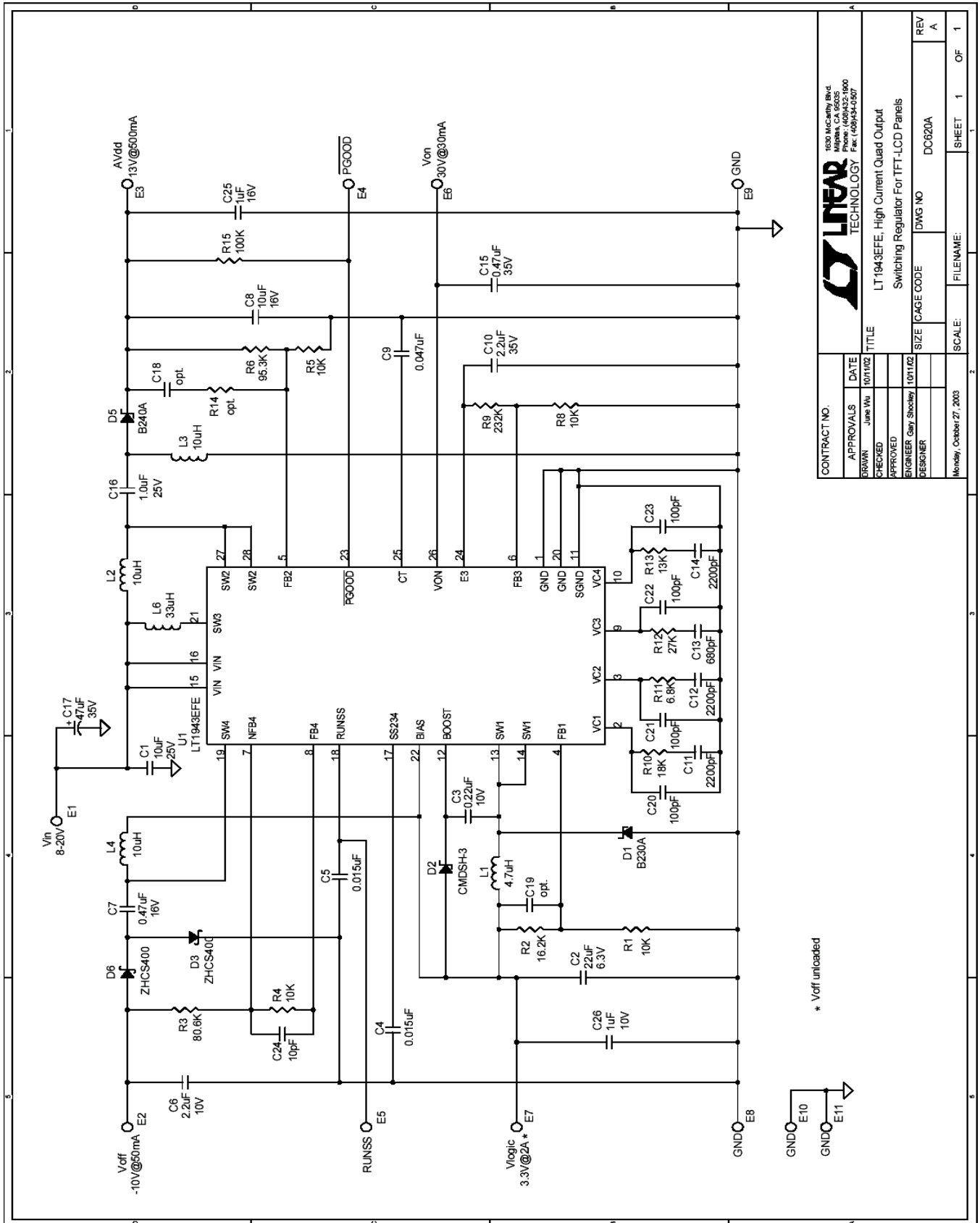

Figure 2. Measuring Input or Output Ripple

QUICK START GUIDE FOR DEMONSTRATION CIRCUIT 620

HIGH CURRENT QUAD OUTPUT SWITCHING REGULATORS FOR TFT-LCD PANELS



CONTRACT NO.		APPROVALS		DATE	
DRAWN		June Wu		10/11/02	
CHECKED		APPROVED			
ENGINEER		Gary Stroscher		10/11/02	
DESIGNER					
TITLE		LT1943EFE, High Current Quad Output Switching Regulator For TFT-LCD Panels			
SIZE		CAGE CODE		DWG NO	
REV		DC620A		REV A	
SCALE:		Monday, October 27, 2003		FILENAME:	
SHEET		1		OF 1	

* Voff unloaded

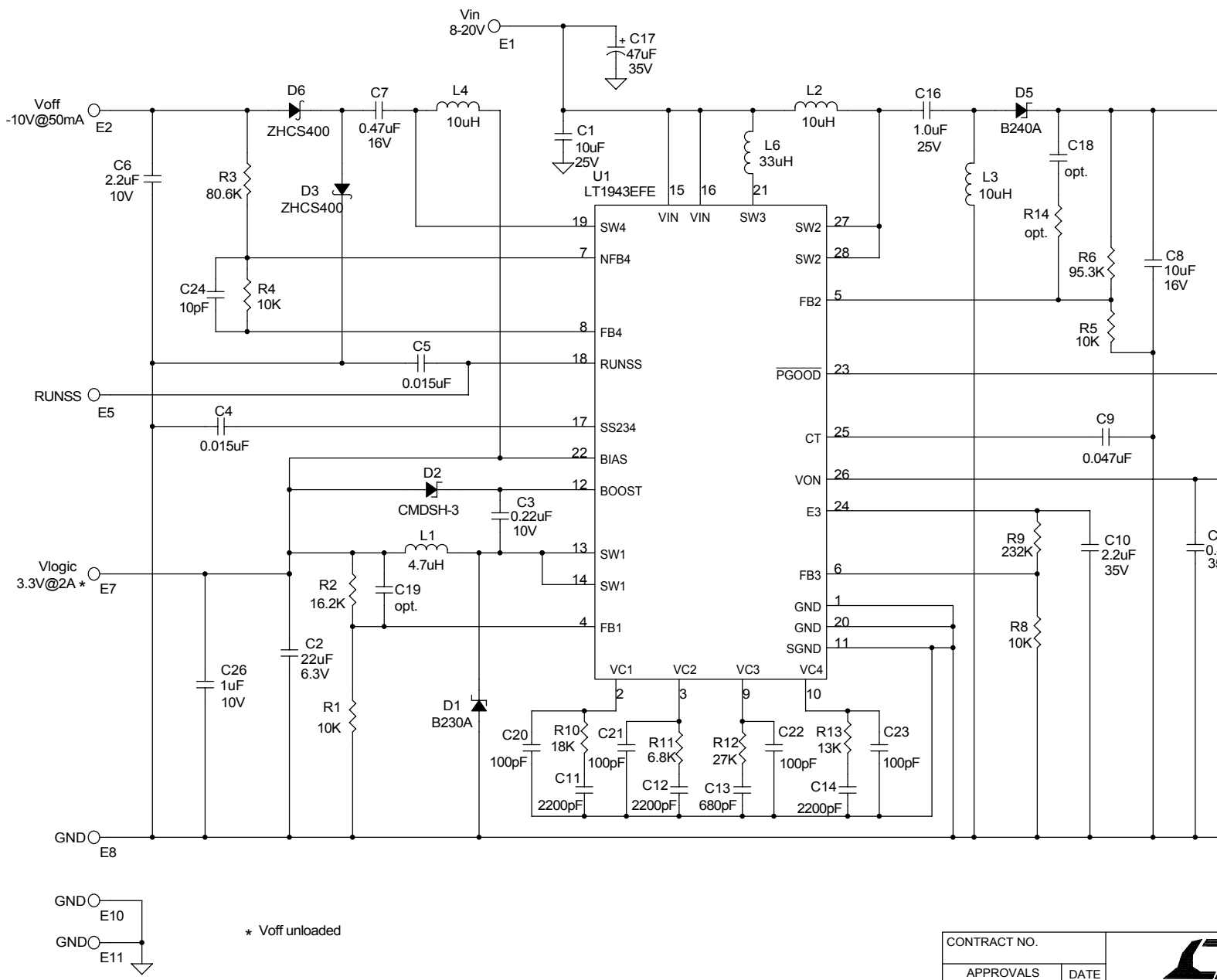

* Voff unloaded

CONTRACT NO.		
APPROVALS	DATE	
DRAWN June Wu	10/11/02	TITLE
CHECKED		LT194
APPROVED		Switch
ENGINEER Gary Shockey	10/11/02	SIZE
DESIGNER		CAGE CODE
Friday, September 12, 2003		SCALE:
		FILE

Linear Technology Corporation

LT1943EFE

Item	Qty	Reference	Part Description	Manufacture / Pa
1	1	C1	CAP., X5R, 10uF, 25V, 20% 1210	Taiyo Yuden, TMK325BJ10
2	1	C8	CAP., X5R, 10uF, 16V, 20% 1210	Taiyo Yuden, EMK325BJ10
3	1	C2	CAP., X5R, 22uF, 6.3V, 20% 1206	Taiyo Yuden, JMK316BJ22
4	1	C3	CAP., X7R, 0.22uF, 10V, 20% 0603	AVX, 0603ZC224MAT2A
5	2	C5,C4	CAP., X7R, 0.015uF, 16V, 20%, 0402	AVX, 0402YC153MAT2A
6	1	C6	CAP., X7R, 2.2uF, 10V, 10% 0805	MuRata, GRM21BR71A225
7	1	C7	CAP., X5R, 0.47uF, 16V, 20% 0603	AVX, 0603YD474MAT2A
8	1	C9	CAP., X5R, 0.047uF, 16V, 10% 0402	AVX, 0402YD473KAT2A
9	1	C10	CAP., X5R, 2.2uF, 35V, 20% 1210	Taiyo Yuden, GMK325BJ22
10	3	C11,C12,C14	CAP., X7R, 2200pF, 50V, 20% 0402	AVX, 04025C222MAT2A
11	1	C13	CAP., X7R, 680pF, 50V, 20% 0402	AVX, 04025C681MAT2A
12	1	C15	CAP., X5R, 0.47uF, 35V, 20% 0805	Taiyo Yuden, GMK212BJ47
13	1	C16	CAP., X5R, 1.0uF, 25V, 10% 0805	AVX, 08053D105KAT2A
14	1	C17	CAP., TANT, 47uF, 35V, 20% 7343	AVX, TAJE476M035R
15	4	C20-C23	CAP., X7R, 100pF, 50V, 20%, 0402	AVX, 04025C101MAT2A
16	0	C18,C19 (OPT.)	CAP., 0402	
17	1	C24	CAP., NPO, 10pF, 50V, 10% 0402	AVX, 04025A100KAT2A
18	1	C25	CAP., X5R, 1.0uF, 16V, 20% 0805	TAIYO YUDEN, EMK212B.
19	1	C26	CAP., X7R, 1.0uF, 10V, 20% 0805	TAIYO YUDEN, LMK212BJ
20	1	D1	Schottky Barrier REC., B230A SMA	Diodes Inc., B230A
21	1	D2	Schottky Diode, CMDSH-3 SOD-323	CENTRAL SEMI., CMDSH-
22	2	D3,D6	Schottky Barriers Dio., ZHCS400, SOD-323	ZETEX, ZHCS400
23	1	D5	Schottky Barrier REC., B240A SMA	Diodes Inc., B240A
24	11	E1-E11	TURRET,	MILL-MAX, 2501-2
25	1	L1	INDUCTOR, 4.7uH RLF7030	TDK, RLF7030T-4R7M3R4
26	2	L2,L3	INDUCTOR, 10uH SLF6028	TDK, SLF6028T-100M1R3
27	1	L4	INDUCTOR, 10uH RLF5018	TDK, RLF5018T-100MR94
28	1	L6	INDUCTOR, 33uH RLF5018	TDK, RLF5018T-330MR51
29	1	R10	RES., CHIP, 18K, 1/16W, 5% 0402	AAC, CR05-183JM
30	1	R11	RES., CHIP, 6.8K, 1/16W, 5% 0402	AAC, CR05-682JM
31	4	R1,R5,R8,R4	RES., CHIP, 10K, 1/16W, 1% 0402	AAC, CR05-1002FM
32	1	R12	RES., CHIP, 27K, 1/16W, 5% 0402	AAC, CR05-273JM
33	1	R13	RES., CHIP, 13K, 1/16W, 5% 0402	AAC, CR05-133JM
34	1	R2	RES., CHIP, 16.2K, 1/16W, 1% 0402	AAC, CR05-1622FM
35	1	R3	RES., CHIP, 80.6K, 1/16W, 1% 0402	AAC, CR05-8062FM
36	1	R6	RES., CHIP, 95.3K, 1/16W, 1% 0402	AAC, CR05-9532FM

Linear Technology Corporation

LT1943EFE

Item	Qty	Reference	Part Description	Manufacture / Pa
37	1	R9	RES., CHIP, 232K, 1/16W, 1% 0402	AAC, CR05-2323FM
38	1	R15	RES., CHIP, 100K, 1/16W, 5% 0603	AAC, CR16-104JM
39	0	R14 (OPT.)	RES., CHIP, 0402	
40	1	U1 (Tape & Reel)	I.C.LT1943EFE, TSSOP28FE	LINEAR., LT1943EFE
41	1		PRINTED CIRCUIT BOARD	DEMO CIRCUIT #620A

X-ON Electronics

Largest Supplier of Electrical and Electronic Components

Click to view similar products for [Power Management IC Development Tools](#) category:

Click to view products by [Analog Devices](#) manufacturer:

Other Similar products are found below :

[EVAL-ADM1168LQEBZ](#) [EVB-EP5348UI](#) [MIC23451-AAAYFL EV](#) [MIC5281YMME EV](#) [DA9063-EVAL](#) [ADP122-3.3-EVALZ](#) [ADP130-0.8-EVALZ](#) [ADP130-1.2-EVALZ](#) [ADP130-1.5-EVALZ](#) [ADP130-1.8-EVALZ](#) [ADP1714-3.3-EVALZ](#) [ADP1716-2.5-EVALZ](#) [ADP1740-1.5-EVALZ](#) [ADP1752-1.5-EVALZ](#) [ADP1828LC-EVALZ](#) [ADP1870-0.3-EVALZ](#) [ADP1871-0.6-EVALZ](#) [ADP1873-0.6-EVALZ](#) [ADP1874-0.3-EVALZ](#) [ADP1882-1.0-EVALZ](#) [ADP199CB-EVALZ](#) [ADP2102-1.25-EVALZ](#) [ADP2102-1.875EVALZ](#) [ADP2102-1.8-EVALZ](#) [ADP2102-2-EVALZ](#) [ADP2102-3-EVALZ](#) [ADP2102-4-EVALZ](#) [ADP2106-1.8-EVALZ](#) [ADP2147CB-110EVALZ](#) [AS3606-DB](#) [BQ24010EVM](#) [BQ24075TEVM](#) [BQ24155EVM](#) [BQ24157EVM-697](#) [BQ24160EVM-742](#) [BQ24296MEVM-655](#) [BQ25010EVM](#) [BQ3055EVM](#) [NCV891330PD50GEVB](#) [ISLUSBI2CKIT1Z](#) [LM2744EVAL](#) [LM2854EVAL](#) [LM3658SD-AEV/NOPB](#) [LM3658SDEV/NOPB](#) [LM3691TL-1.8EV/NOPB](#) [LM4510SDEV/NOPB](#) [LM5033SD-EVAL](#) [LP38512TS-1.8EV](#) [EVAL-ADM1186-1MBZ](#) [EVAL-ADM1186-2MBZ](#)