

## DESCRIPTION

Demonstration circuit 628A is a single channel 5V hot swap controller featuring the LTC4210.

The LTC<sup>®</sup>4210 is a 6-pin SOT-23 Hot Swap<sup>™</sup> controller that allows a board to be safely inserted and removed from a live back plane. An internal high side switch driver controls the GATE of an external N-channel MOSFET with a supply voltage ranging from 2.7V to 16.5V. The LTC4210 provides the initial timing cycle and allows the GATE to be ramped up at an adjustable rate.

The LTC4210 features a fast current limit loop providing active current limiting together with a circuit breaker timer. The signal at the ON pin turns the chip on and off and is also used for the reset function.

**Design files for this circuit board are available. Call the LTC factory.**

Hot Swap is a trademark of Linear Technology Corporation

**Table 1. Performance Summary (T<sub>A</sub> = 25°C)**

PARAMETER	CONDITION	VALUE
Minimum Input Voltage		2.7V
Maximum Input Voltage	(Limited by Transorb Z1)	12V
Output Voltage V <sub>OUT</sub>	$V_{OUT} = V_{IN} - I_{LOAD} \times (R_{SENSE} + R_{FET})$	$= V_{IN} - I_{LOAD} \times (0.022\Omega)$
Maximum Output Current	$I_{LIMIT} < (V_{CB} / R_{SENSE})$ ; Remember to consider tolerances (44mV ≤ V <sub>CB</sub> ≤ 56mV)	6A
On/Off Control (Connection Sense Turret)	Logic High Voltage-On	2.6V
	V <sub>ONHYST</sub>	160mV

## OPERATING PRINCIPLES

The LTC4210 combines Hot Swap<sup>™</sup> inrush current limiting with an electronic circuit breaker function. The LTC4210 uses a single capacitor, C<sub>TIMER</sub> to set multiple timing cycles for the initial power up time,

the circuit breaker hold-off time and automatic retry duty cycle time. (The LTC4210-1 version provides automatic retry while the LTC4210-2 version provides latch-off after fault timeout.)

## QUICK START PROCEDURE

**NOTE:** Demonstration circuit 628A is easy to set up to evaluate the performance of the LTC4210. Refer to Figure 1. for proper measurement equipment setup and follow the procedure below:

1. With power off, connect the input power supply to V<sub>IN</sub> and GND and a load between V<sub>OUT</sub> and GND. The load resistance should be >V<sub>in</sub>/6A or pull less than 6A.
2. Turn on the power at the input.

# QUICK START GUIDE FOR DEMONSTRATION CIRCUIT 628A

## SINGLE CHANNEL 5V HOT SWAP CONTROLLER

**NOTE:** Make sure that the input voltage does not exceed 12V or the transient suppressor Z1 will begin to conduct. The transient suppressor Z1 protects the input from the turn off voltage spike resulting from interrupting the high currents flowing through the lead inductance of the back plane or leads from the power source.

3. Connect the *Connection Sense* turret to  $V_{IN}$  to enable the LTC4210. Monitor the output voltage turn on time waveform or inrush current if a current probe is available.

**NOTE:** If there is no output, temporarily disconnect the load to make sure that the load is not set too high.

**NOTE:** Connectors specifically designed for Hot Swap have a special pin configuration that uses extra long pins to first connect the GND and power signal, then normal length pins for the rest of the signals and a special short pin for the Connection Sense signal. This pin configuration prevents turning on the power to the Hot Swapped board before the connector is completely engaged.

4. Once the proper output voltages are established, increase the load above 6A and observe the circuit breaker function. Disconnect the Connection Sense turret from  $V_{IN}$ , connect a large (100uF) capacitor across  $V_{OUT}$  and GND then connect the Connection Sense turret to  $V_{IN}$  and monitor  $V_{OUT}$ . Observe the current limiting action during turn on.

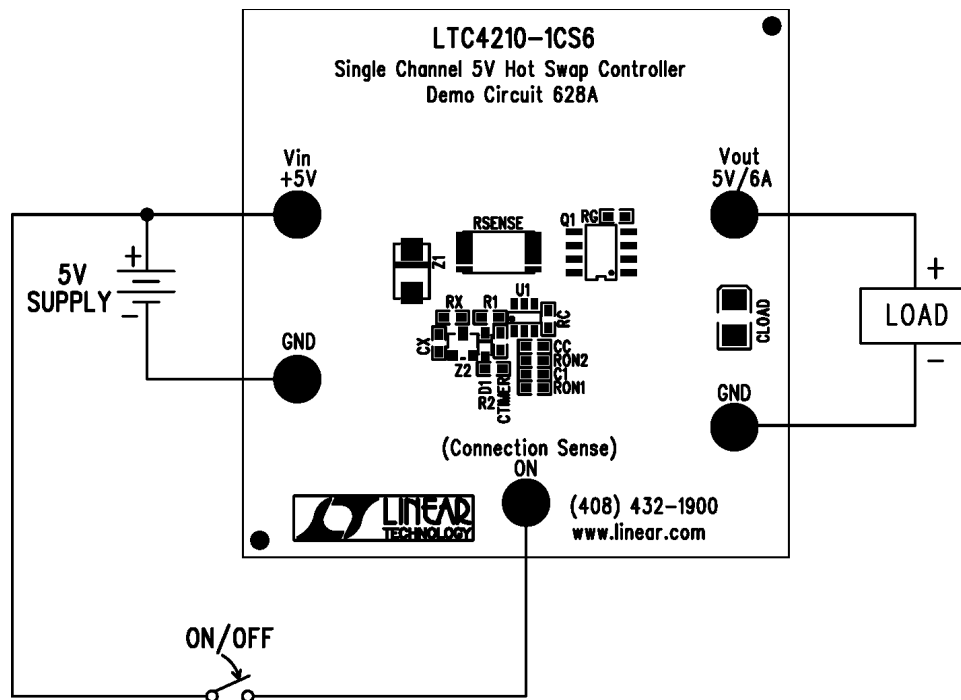
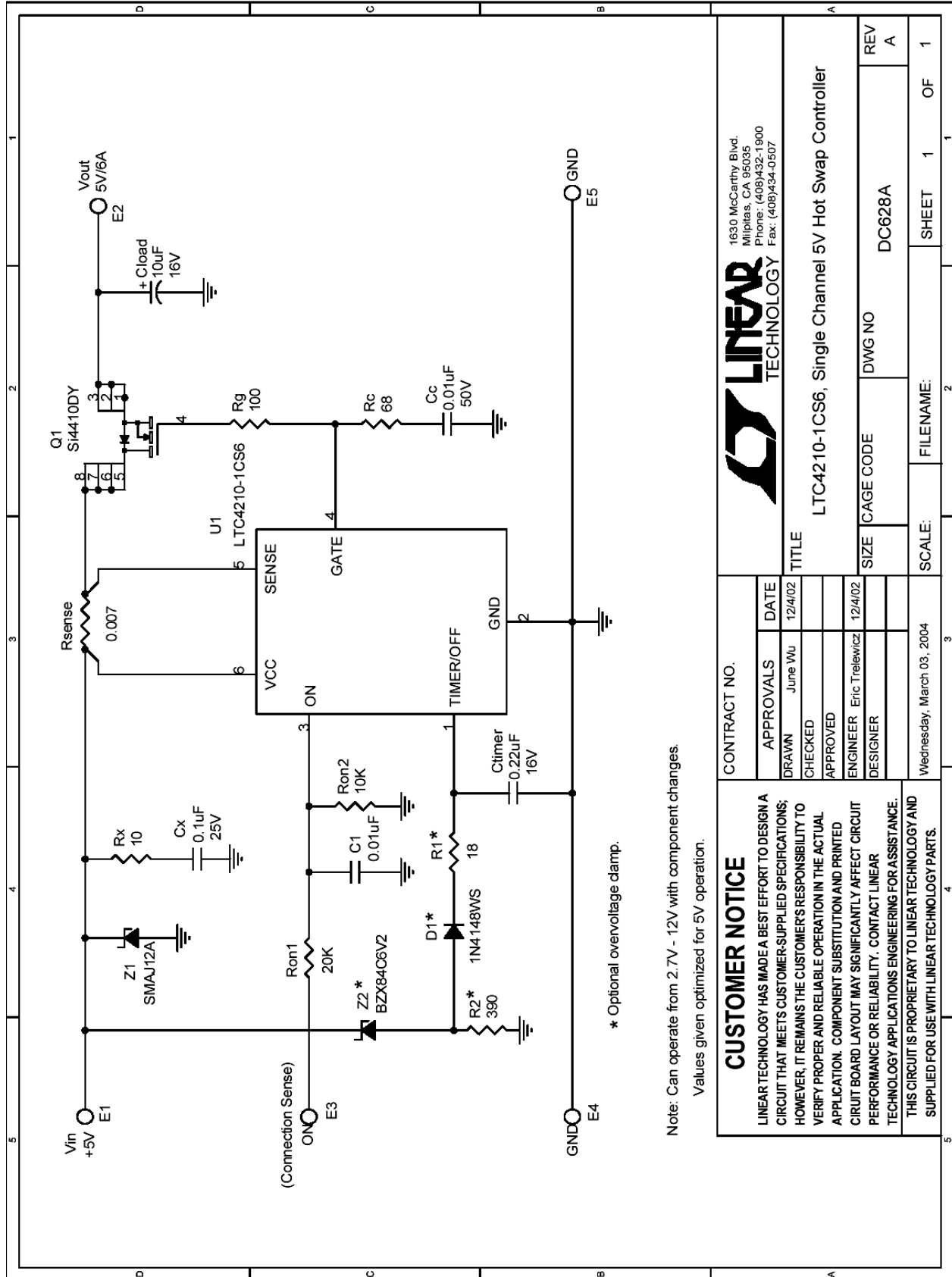

Figure 1. Proper Measurement Equipment Setup

# QUICK START GUIDE FOR DEMONSTRATION CIRCUIT 628A

## SINGLE CHANNEL 5V HOT SWAP CONTROLLER



Note: Can operate from 2.7V - 12V with component changes.  
Values given optimized for 5V operation.

<b>CONTRACT NO.</b>		<b>LINEAR TECHNOLOGY</b> 1630 McCarthy Blvd. Milpitas, CA 95035 Phone: (408)432-1900 Fax: (408)434-0507	
<b>APPROVALS</b>	<b>DATE</b>	<b>TITLE</b>	
DRAWN: June Wu	12/4/02	LTC4210-1CS6, Single Channel 5V Hot Swap Controller	
CHECKED:		<b>SIZE</b>	<b>DWG NO</b>
APPROVED:			DC628A
ENGINEER: Eric Trelewicz	12/4/02	<b>SCALE:</b>	<b>REV</b>
DESIGNER:		FILENAME:	A
Wednesday, March 03, 2004		SHEET	1 OF 1

### CUSTOMER NOTICE

LINEAR TECHNOLOGY HAS MADE A BEST EFFORT TO DESIGN A CIRCUIT THAT MEETS CUSTOMER-SUPPLIED SPECIFICATIONS; HOWEVER, IT REMAINS THE CUSTOMER'S RESPONSIBILITY TO VERIFY PROPER AND RELIABLE OPERATION IN THE ACTUAL APPLICATION. COMPONENT SUBSTITUTION AND PRINTED CIRCUIT BOARD LAYOUT MAY SIGNIFICANTLY AFFECT CIRCUIT PERFORMANCE OR RELIABILITY. CONTACT LINEAR TECHNOLOGY APPLICATIONS ENGINEERING FOR ASSISTANCE. THIS CIRCUIT IS PROPRIETARY TO LINEAR TECHNOLOGY AND SUPPLIED FOR USE WITH LINEAR TECHNOLOGY PARTS.

## X-ON Electronics

Largest Supplier of Electrical and Electronic Components

*Click to view similar products for [Power Management IC Development Tools](#) category:*

*Click to view products by [Analog Devices](#) manufacturer:*

Other Similar products are found below :

[EVAL-ADM1168LQEBZ](#) [EVB-EP5348UI](#) [MIC23451-AAAYFL EV](#) [MIC5281YMME EV](#) [DA9063-EVAL](#) [ADP122-3.3-EVALZ](#) [ADP130-0.8-EVALZ](#) [ADP130-1.2-EVALZ](#) [ADP130-1.5-EVALZ](#) [ADP130-1.8-EVALZ](#) [ADP1714-3.3-EVALZ](#) [ADP1716-2.5-EVALZ](#) [ADP1740-1.5-EVALZ](#) [ADP1752-1.5-EVALZ](#) [ADP1828LC-EVALZ](#) [ADP1870-0.3-EVALZ](#) [ADP1871-0.6-EVALZ](#) [ADP1873-0.6-EVALZ](#) [ADP1874-0.3-EVALZ](#) [ADP1882-1.0-EVALZ](#) [ADP199CB-EVALZ](#) [ADP2102-1.25-EVALZ](#) [ADP2102-1.875EVALZ](#) [ADP2102-1.8-EVALZ](#) [ADP2102-2-EVALZ](#) [ADP2102-3-EVALZ](#) [ADP2102-4-EVALZ](#) [ADP2106-1.8-EVALZ](#) [ADP2147CB-110EVALZ](#) [AS3606-DB](#) [BQ24010EVM](#) [BQ24075TEVM](#) [BQ24155EVM](#) [BQ24157EVM-697](#) [BQ24160EVM-742](#) [BQ24296MEVM-655](#) [BQ25010EVM](#) [BQ3055EVM](#) [NCV891330PD50GEVB](#) [ISLUSBI2CKIT1Z](#) [LM2744EVAL](#) [LM2854EVAL](#) [LM3658SD-AEV/NOPB](#) [LM3658SDEV/NOPB](#) [LM3691TL-1.8EV/NOPB](#) [LM4510SDEV/NOPB](#) [LM5033SD-EVAL](#) [LP38512TS-1.8EV](#) [EVAL-ADM1186-1MBZ](#) [EVAL-ADM1186-2MBZ](#)