

## DESCRIPTION

Demonstration circuit 639 is a monolithic step-down DC/DC switching converter featuring the LT<sup>®</sup>1977. The board is optimized for 3.3V output at up to 1A load current for a steady state input voltage range of 4V to about 36V\* with input transients up to 60V. *Minimum on-time restrictions and 3.3V output may limit the steady state maximum input voltage to 36V before pulse skipping occurs.* With its wide input voltage range, 1.5A internal power switch, 100 $\mu$ A supply current (at input voltages above 14V), 500kHz switching frequency and thermally enhanced package, the LT1977 is a very versatile and powerful IC for DC/DC converters that require compact space, high efficiency at both heavy and light loads and high input voltage.

The LT1977 500kHz switching frequency allows all of the components to be small, surface mount devices. Synchronization with an external clock of up to 700kHz is possible. The current-mode control topology creates fast transient response and good loop stability with a minimum number of external components. The low resistance internal power switch (0.2 $\Omega$ ) achieves high efficiencies of up to 80%. The shutdown pin can be used to program undervoltage lockout or place the part in micropower shutdown, reducing supply current to less than 1 $\mu$ A by driving the pin low. Burst Mode<sup>™</sup> reduces zero load current

to under 100 $\mu$ A at most input voltages while maintaining a regulated output. A power good comparator and a timing delay can be used for additional system diagnostics and sequencing. The soft start function reduces inrush current at soft start and output voltage overshoot. An optional Power Good Feedback output terminal can be used to monitor or control power good feedback externally.

The LT1977 datasheet gives a complete description of the part, operation and applications information. The datasheet must be read in conjunction with this Quick Start Guide for demonstration circuit 639. In particular, the datasheet section on 'Thermal Calculations' is important for estimating whether a given application's combination of input voltage, load current and frequency will cause the LT1977 to exceed its absolute maximum rated junction temperature. The LT1977 is assembled in a small 16-pin thermally enhanced package with exposed pad where proper board layout is essential for maximum thermal performance. See the datasheet section 'Layout Considerations'.

**Design files for this circuit board are available. Call the LTC factory.**

---

LT is a trademark of Linear Technology Corporation

## QUICK START PROCEDURE

Demonstration circuit 639 is easy to set up to evaluate the performance of the LT1977. Refer to Figure 1. for proper measurement equipment setup and follow the procedure below:

**NOTE:** Make sure that the input voltage does not exceed 60V.

**NOTE:** The synchronization, shutdown, and power good functions are optional and their terminals can

be left floating (disconnected) if their functions are not being used.

**NOTE:** Do not hot-plug the input voltage terminal VIN. The absolute maximum voltage on VIN is 60V and hot-plugging a power supply through wire leads to the demonstration circuit can cause the voltage on the extremely low-ESR ceramic input capacitor to ring to twice its DC value. This is due to high currents instantaneously generated in the inductive supply leads

# QUICK START GUIDE FOR DEMONSTRATION CIRCUIT 639

## 1.5A, 500KHZ STEP-DOWN CONVERTER WITH BURST MODE

from an input voltage step on the low-ESR ceramic input capacitor. A bulky higher-ESR capacitor, and an additional inductive filter can be added to the circuit to dampen hot-plug transient ringing. *See Application Note 88 for more details.* In order to protect the IC, a transient voltage suppressor diode can be added between VIN and GND terminals to absorb any high voltage transient ringing that may occur due to hot-plugging.

**NOTE:** Connect the power supply (with power off), load, and meters as shown in Figure 1.

1. After all connections are made, turn on input power and verify that the output voltage is 3.3V.

**NOTE:** If the output voltage is too low, temporarily disconnect the load to make sure that the load is not set too high.

2. Once the proper output voltages are established, adjust the load within the operating range and observe the output voltage regulation, ripple voltage, efficiency and other parameters.

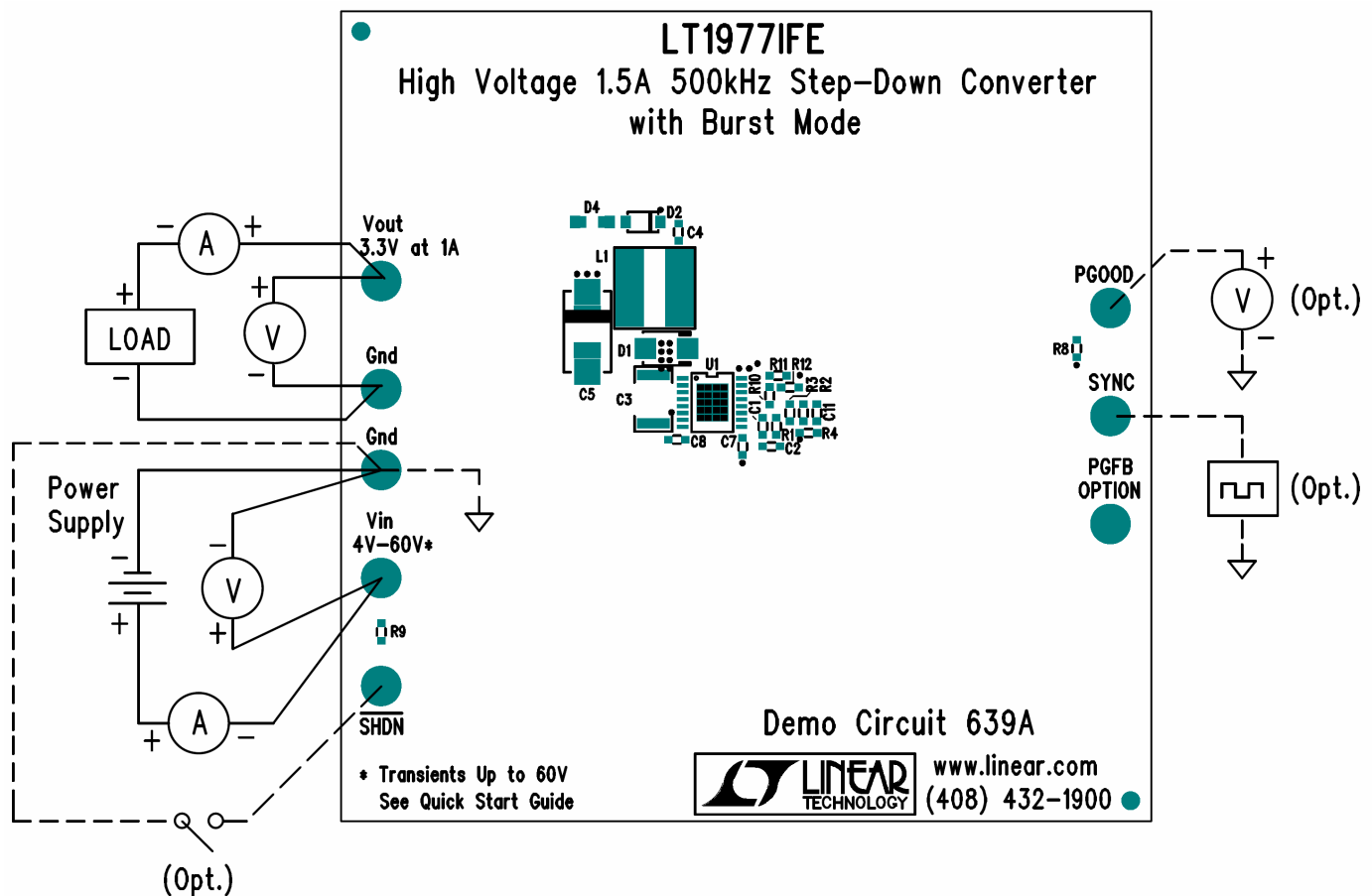
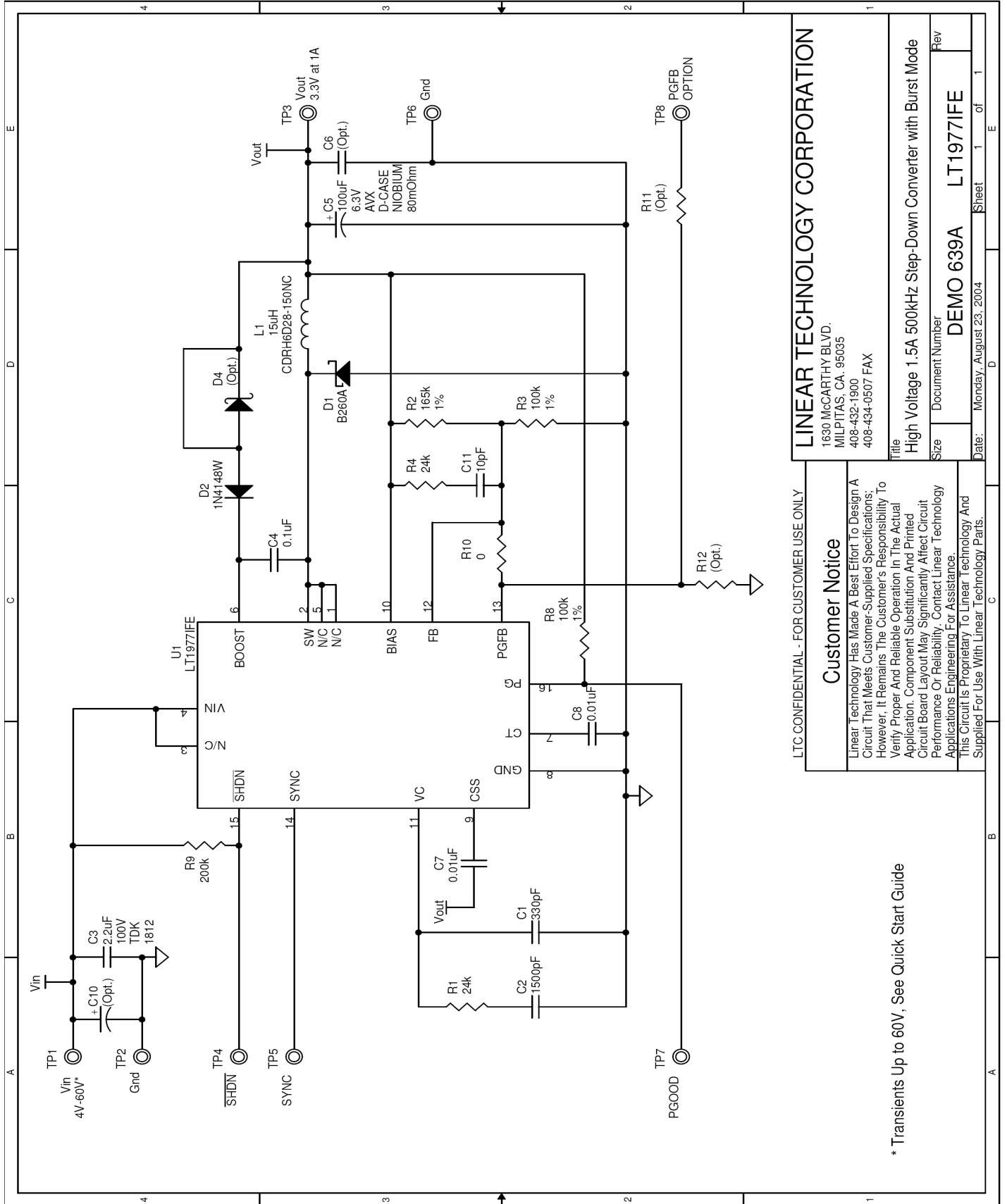

Figure 1. Proper Measurement Equipment Setup

# QUICK START GUIDE FOR DEMONSTRATION CIRCUIT 639

## 1.5A, 500KHZ STEP-DOWN CONVERTER WITH BURST MODE



\* Transients up to 60V, See Quick Start Guide

LTC-CONFIDENTIAL - FOR CUSTOMER USE ONLY

### Customer Notice

Linear Technology Has Made A Best Effort To Design A Circuit That Meets Customer-Supplied Specifications. However, It Remains The Customer's Responsibility To Verify Proper And Reliable Operation In The Actual Application. Component Substitution And Printed Circuit Board Layout May Significantly Affect Circuit Performance Or Reliability. Contact Linear Technology Applications Engineering For Assistance. This Circuit Is Proprietary To Linear Technology And Supplied For Use With Linear Technology Parts.

### LINEAR TECHNOLOGY CORPORATION

1630 McCARTHY BLVD.  
MILPITAS, CA. 95035  
408-432-1900  
408-434-0507 FAX

Title: High Voltage 1.5A 500kHz Step-Down Converter with Burst Mode

Size: Document Number: DEMO 639A LT1977IFE

Date: Monday, August 23, 2004 Sheet 1 of 1

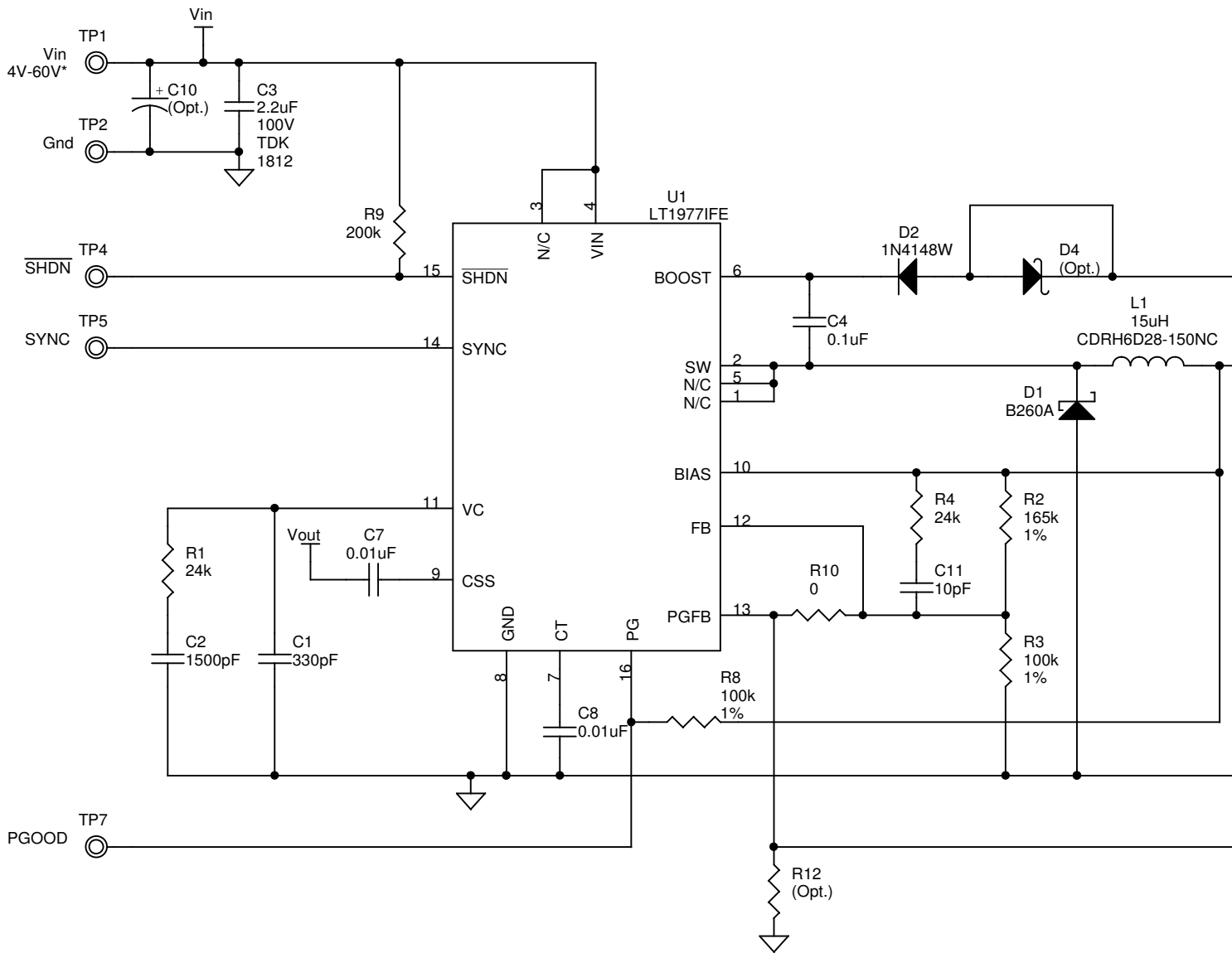

\* Transients Up to 60V, See Quick Start Guide

LTC CONFIDENTIAL - FOR CUSTOMER USE ONLY

### Customer Notice

Linear Technology Has Made A Best Effort To Design A Circuit That Meets Customer-Supplied Specifications; However, It Remains The Customer's Responsibility To Verify Proper And Reliable Operation In The Actual Application. Component Substitution And Printed Circuit Board Layout May Significantly Affect Circuit Performance Or Reliability. Contact Linear Technology Applications Engineering For Assistance.  
This Circuit Is Proprietary To Linear Technology And Supplied For Use With Linear Technology Parts.

### LINEAR TECHNO

1630 McCARTHY BLVD.  
MILPITAS, CA. 95035  
408-432-1900  
408-434-0507 FAX

Title  
High Voltage 1.5A 500kHz Ste

Size Document Number

DEMO 6

Date: Monday, August 23, 2004

# Linear Technology Corporation

LT1977IFE

<b>Item</b>	<b>Qty</b>	<b>Reference</b>	<b>Part Description</b>	<b>Manufacture / Part #</b>
1	1	C11	CAP., NPO, 10pF, 25V, 5%	AVX 06033A100JAT2A
2	1	C1	CAP., NPO , 330pF, 25V, 5%	AVX 06033A331JAT2A
3	1	C2	CAP., NPO, 1500pF, 25V, 5%	AVX 06033A152JAT2A
4	1	C3	CAP., X7R, 2.2uF, 100V, 10%	TDK C4532X7R2A225K
5	2	C7,C8	CAP., X7R, 0.01uF, 16V, 10%	AVX O603YC103KAT
6	1	C4	CAP., X7R 0.1uF 16V 20%	TAIYO YUDEN EMK107BJ104MA
7	1	C5	CAP., Niobium 100uF 6.3V D case	AVX NOSD107M006
8	0	C6,C10	(OPT)	
9	1	D1	DIODE, chottky Rect., 2.0Amp\60V	DIODES INC. B260A-13 SMA
10	1	D2	DIODE, Switching Diode	DIODES INC., 1N4148W-7 SOD
11	0	D4	(OPT)	
12	1	L1	INDUCTOR, 15uH	SUMIDA CDRH6D28-150NC
13	1	R10	RES., Chip 0	AAC CJ06-000M
14	1	R2	RES., Chip 165K 0.06W 1%	AAC CR16-1653FM
15	2	R3,R8	RES., Chip 100K 0.1W 1%	AAC CR16-1003FM
16	1	R9	RES., Chip 200K 0.06W 5%	AAC CR16-204JM
17	2	R1,R4	RES., Chip 24K 0.06W, 5%	AAC CR16-243JM
18	0	R11,R12	(OPT)	
19	7	TP1-TP7	TURRET, Testpoint	Mill Max 2501-2
20	0	TP8	(OPT)	
21	1	U1	I.C., Step-Down Reg.	Linear Tech. Corp. LT1977IFE ****

## X-ON Electronics

Largest Supplier of Electrical and Electronic Components

*Click to view similar products for [Power Management IC Development Tools](#) category:*

*Click to view products by [Analog Devices](#) manufacturer:*

Other Similar products are found below :

[EVAL-ADM1168LQEBZ](#) [EVB-EP5348UI](#) [MIC23451-AAAYFL EV](#) [MIC5281YMME EV](#) [DA9063-EVAL](#) [ADP122-3.3-EVALZ](#) [ADP130-0.8-EVALZ](#) [ADP130-1.2-EVALZ](#) [ADP130-1.5-EVALZ](#) [ADP130-1.8-EVALZ](#) [ADP1714-3.3-EVALZ](#) [ADP1716-2.5-EVALZ](#) [ADP1740-1.5-EVALZ](#) [ADP1752-1.5-EVALZ](#) [ADP1828LC-EVALZ](#) [ADP1870-0.3-EVALZ](#) [ADP1871-0.6-EVALZ](#) [ADP1873-0.6-EVALZ](#) [ADP1874-0.3-EVALZ](#) [ADP1882-1.0-EVALZ](#) [ADP199CB-EVALZ](#) [ADP2102-1.25-EVALZ](#) [ADP2102-1.875EVALZ](#) [ADP2102-1.8-EVALZ](#) [ADP2102-2-EVALZ](#) [ADP2102-3-EVALZ](#) [ADP2102-4-EVALZ](#) [ADP2106-1.8-EVALZ](#) [ADP2147CB-110EVALZ](#) [AS3606-DB](#) [BQ24010EVM](#) [BQ24075TEVM](#) [BQ24155EVM](#) [BQ24157EVM-697](#) [BQ24160EVM-742](#) [BQ24296MEVM-655](#) [BQ25010EVM](#) [BQ3055EVM](#) [NCV891330PD50GEVB](#) [ISLUSBI2CKIT1Z](#) [LM2744EVAL](#) [LM2854EVAL](#) [LM3658SD-AEV/NOPB](#) [LM3658SDEV/NOPB](#) [LM3691TL-1.8EV/NOPB](#) [LM4510SDEV/NOPB](#) [LM5033SD-EVAL](#) [LP38512TS-1.8EV](#) [EVAL-ADM1186-1MBZ](#) [EVAL-ADM1186-2MBZ](#)