

QUICK START GUIDE FOR DEMONSTRATION CIRCUIT 642

HIGH LINEARITY UPCONVERTING MIXER

LT5521

DESCRIPTION

Demonstration circuit 642 is an upconverting mixer featuring the LT[®]5521. The LT[®]5521 is a 10MHz to 3.7GHz High Linearity Up/Downconverting Mixer optimized for wireless and cable infrastructure applications. A high-speed, internally matched LO amplifier drives a double-balanced mixer core, allowing the use of a low power, single-ended LO source.

The IF port can be easily matched to a broad range of frequencies for use in many different applications.

Demonstration circuit 642 is designed for an RF output frequency range from 1.75GHz to 2.15GHz and is optimized for a 250MHz IF input frequency.

Design files for this circuit board are available. Call the LTC factory.

LT is a registered trademark of Linear Technology Corporation.

Table 1. Typical Performance Summary (T_A = 25°C)

PARAMETER	CONDITION (f _{IF} = 250MHz, f _{LO} = 1700MHz)	VALUE
Supply Voltage		4.5V to 5.25V
Supply Current	V _{CC} = 5V, EN = High	82mA
Maximum Shutdown Current	V _{CC} = 5V, EN = Low	100μA
RF Frequency Range		1.75GHz to 2.15GHz
IF Input Return Loss	Z ₀ = 50 Ω, with external matching	15dB
LO Input Return Loss	Z ₀ = 50	12dB
RF Output Return Loss	Z ₀ = 50	12dB
LO Input Power		-10dBm to 0dBm
Conversion Gain	P _{IF} = -7dBm, P _{LO} = -5dBm	-0.5dB
SSB Noise Figure	P _{LO} = -5dBm	12.5dB
Input 3 rd Order Intercept	2-Tone, -7dBm/Tone, Δf = 5MHz, P _{LO} = -5dBm	+24.2dBm
Input 2 nd Order Intercept	2-Tone, -7dBm/Tone, Δf = 5MHz, P _{LO} = -5dBm	+49dBm
Input 1dB Compression	P _{LO} = -5dBm	+10dBm
LO to RF leakage	P _{LO} = -5dBm	-42dBm
LO to IF leakage	P _{LO} = -5dBm	-40dBm

APPLICATION NOTE

FREQUENCY RANGE

Demonstration circuit 642 is optimized for an IF input frequency of 250MHz. This frequency is set by the input IF matching components on the PCB. Other values may be used to maintain best performance for IF frequencies ranging from 10MHz to 3GHz.

CURRENT CONSUMPTION

If lower power consumption is required, the LT[®]5521's supply current can be reduced by increasing the value

of the DC return resistors, R1, R2. Operation at a lower supply current will, however, degrade linearity.

LO TO RF LEAKAGE

Minimum LO to RF leakage is realized when R1 & R2 are closely matched; 0.1% tolerance resistors are recommended for this reason. Resistors with a greater tolerance (ie; 1%) may be used with some degradation of LO to RF leakage.

QUICK START PROCEDURE

Demonstration circuit 642 is easy to set up to evaluate the performance of the LT[®]5521. Refer to Figure 1 for proper measurement equipment setup and follow the procedure below:

NOTE:

- a. Use high performance signal generators with low harmonic output for 2nd & 3rd order distortion measurements. Otherwise, low-pass filters at the signal generator outputs should be used to suppress harmonics, particularly the 2nd harmonic.
 - b. High quality combiners that provide a 50 ohm termination on all ports and have good port-to-port isolation should be used. Attenuators on the outputs of the signal generators are recommended to further improve source isolation and to reduce reflection into the sources.
1. Connect all test equipment as shown in Figure 1.
 2. Set the DC power supply's current limit to 90mA, and adjust output voltage to 5V.
 3. Connect Vcc to the 5V DC supply, and then connect EN to 5V; the mixer is enabled (on).
 4. Set Signal Generator #1 to provide a 1700MHz, -5dBm, CW signal to the demo board LO input port.
 5. Set the Signal Generators #2 and #3 to provide two -10dBm CW signals to the demo board RF input port—one at 250MHz, and the other at 255MHz.
 6. To measure 3rd order distortion and conversion gain, set the Spectrum Analyzer start and stop frequencies to 1940MHz and 1965MHz, respectively. Sufficient spectrum analyzer input attenuation should be used to avoid distortion in the instrument.
 7. The 3rd order intercept point is equal to $(P_1 - P_3) / 2 + P_{in}$, where P_1 is the power level of the two fundamental output tones at 1950MHz and 1955MHz, P_3 is the 3rd order product at 1945MHz and 1960MHz, and P_{in} is the input power (in this case, -7dBm). All units are in dBm.
 8. To measure input 2nd order distortion, set the Spectrum Analyzer start and stop frequencies to 2204MHz and 2206MHz, respectively. Sufficient spectrum analyzer input attenuation should be used to avoid distortion in the instrument.
 9. The 2nd order intercept point is equal to $P_1 - P_2 + P_{in}$, where P_1 is the power level of the fundamental output tone at 1950MHz, P_2 is the 2nd order product at 2205MHz, and P_{in} is the input power (in this case, -7dBm). All units are in dBm.

QUICK START GUIDE FOR DEMONSTRATION CIRCUIT 642

HIGH LINEARITY UPCONVERTING MIXER

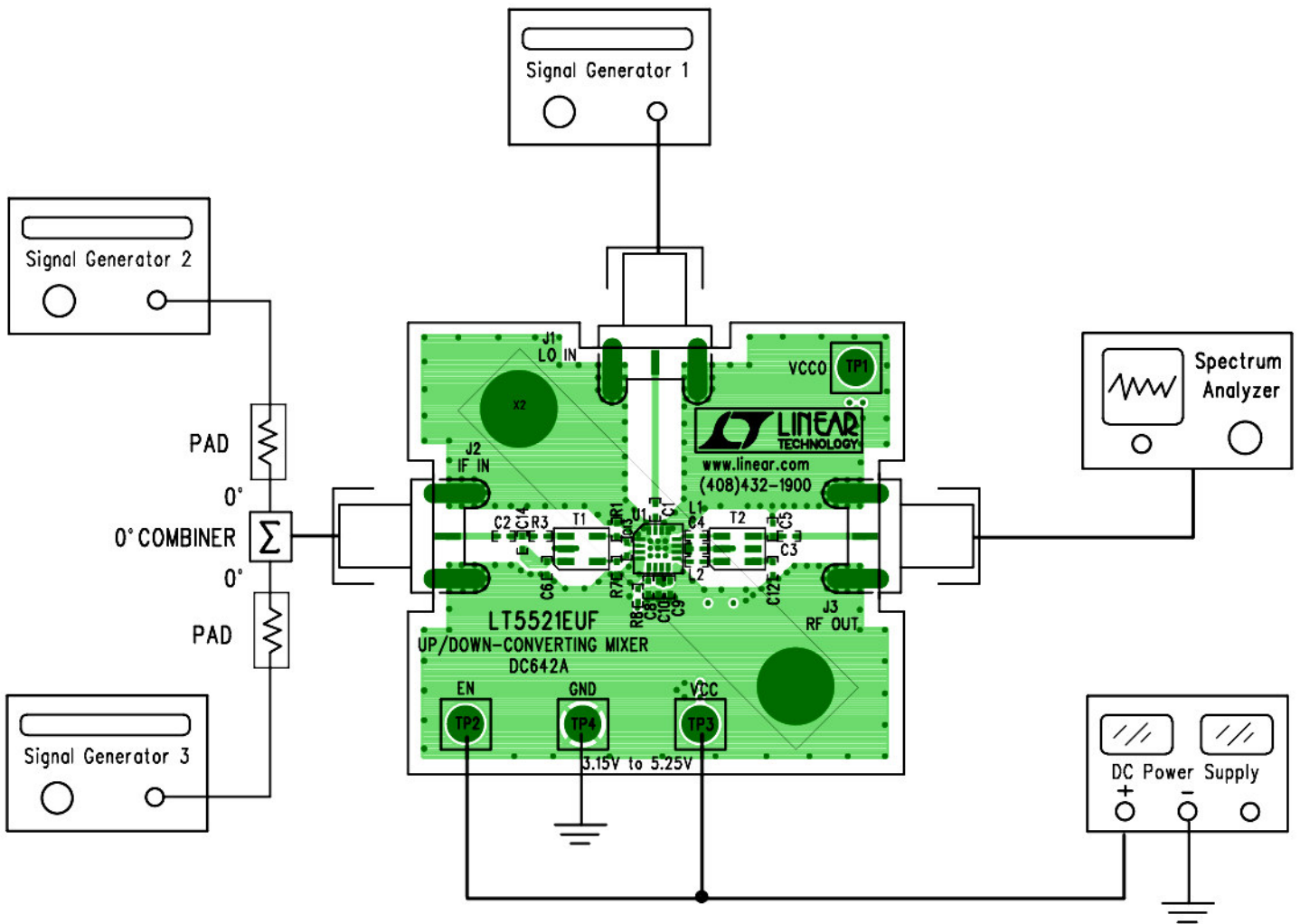

Figure 1. Proper Measurement Equipment Setup

QUICK START GUIDE FOR DEMONSTRATION CIRCUIT 642 HIGH LINEARITY UP/CONVERTING MIXER

PROPRIETARY DATA:
This circuit is proprietary to Linear Technology and supplied for use with Linear Technology parts.
CUSTOMER NOTICE: Linear Technology has made a best effort to design a circuit that meets customer-specified specifications; however, it remains the customer's responsibility to verify proper and reliable operation in the actual application. Component substitution and printed circuit board layout may significantly affect circuit performance or reliability. Contact Linear Technology Applications Engineering for assistance.

LTC CONFIDENTIAL - For Customer Use Only

REVISION HISTORY		
ECO	DESCRIPTION	DATE
1	INITIATE	3/25/03
2	ADD C12	4/15/03
3	REVISED	9/11/03
4	REVISE AND UPDATE	10/27/03
5	REF DESIG. R3 & C14 SWAP	12/17/03
6	CHG COMPONENT T1 & T2 - SEE BOM	6/16/04
-	-	-
-	-	-
-	-	-

CONTRACT NO.

APPROVALS	DATE
DRAWN L. SANTOS	6/16/04
CHECKED DOUG S.	6/16/04
APPROVED	
ENGINEER DOUG S.	6/16/04
DESIGNER	

LINEAR TECHNOLOGY

1630 McCarthy Blvd.
Milpitas, CA 95035
Phone: (408)432-1900
Fax: (408)434-0507

TITLE
SCHEMATIC, LT5521, UP/DOWN-CONVERTING MIXER PCB

REV	CAGE CODE	DWG NO	REV	OF	SHEET
6	A	DC642A	6	1	1

SCALE: NONE FILENAME: 642_6.DSN SHEET 1 OF 1

UNLESS OTHERWISE SPECIFIED
DIMENSIONS ARE IN INCHES
TOLERANCE ON ANGLE ...
2 PLACES ... 3 PLACES ...
INTERPRET DIM AND TOL
PER ASME Y14.5M -1994

THIRD ANGLE PROJECTION

DO NOT SCALE DRAWING

Thursday, June 17, 2004

DATE

Thursday, June 17, 2004

X-ON Electronics

Largest Supplier of Electrical and Electronic Components

Click to view similar products for [RF Development Tools](#) category:

Click to view products by [Analog Devices](#) manufacturer:

Other Similar products are found below :

[MAAM-011117](#) [MAAP-015036-DIEEV2](#) [EV1HMC1113LP5](#) [EV1HMC6146BLC5A](#) [EV1HMC637ALP5](#) [EVAL-ADG919EBZ](#) [ADL5363-EVALZ](#) [LMV228SDEVAL](#) [SKYA21001-EVB](#) [SMP1331-085-EVB](#) [EV1HMC618ALP3](#) [EVAL01-HMC1041LC4](#) [MAAL-011111-000SMB](#)
[MAAM-009633-001SMB](#) [107712-HMC369LP3](#) [107780-HMC322ALP4](#) [SP000416870](#) [EV1HMC470ALP3](#) [EV1HMC520ALC4](#)
[EV1HMC244AG16](#) [MAX2614EVKIT#](#) [124694-HMC742ALP5](#) [SC20ASATEA-8GB-STD](#) [MAX2837EVKIT+](#) [MAX2612EVKIT#](#)
[MAX2692EVKIT#](#) [SKY12343-364LF-EVB](#) [108703-HMC452QS16G](#) [EV1HMC863ALC4](#) [EV1HMC427ALP3E](#) [119197-HMC658LP2](#)
[EV1HMC647ALP6](#) [ADL5725-EVALZ](#) [106815-HMC441LM1](#) [EV1HMC1018ALP4](#) [UXN14M9PE](#) [MAX2016EVKIT](#) [EV1HMC939ALP4](#)
[MAX2410EVKIT](#) [MAX2204EVKIT+](#) [EV1HMC8073LP3D](#) [SIMSA868-DKL](#) [SIMSA868C-DKL](#) [SKY65806-636EK1](#) [SKY68020-11EK1](#)
[SKY67159-396EK1](#) [SKY66181-11-EK1](#) [SKY65804-696EK1](#) [SKY13396-397LF-EVB](#) [SKY13380-350LF-EVB](#)