

QUICK START GUIDE FOR DEMONSTRATION CIRCUIT 654

LI-ION BATTERY CHARGER IN SOT23-6 WITH EXTERNAL TERMINATION

LTC4057ES5-4.2

DESCRIPTION

Demonstration circuit 654 is a simple single Li-Ion battery charger featuring the LTC4057ES5-4.2. Maximum charge current is 600mA. The LTC4057 provides the constant current, constant voltage source required to charge Li-Ion batteries. The LTC4057 does not terminate charging, that is the respon-

sibility of the system. The LTC4057 does however indicate battery-charging current on the PROG pin, which simplifies the task for the external terminator.

Design files for this circuit board are available. Call the LTC factory.

Table 1. Performance Summary ($T_A = 25^\circ\text{C}$)

PARAMETER	CONDITION	VALUE
Minimum Input Voltage		4.25V
Maximum Input Voltage		6.5V
Float Voltage V	$V_{IN} = 5V$	4.2V $\pm 1\%$
Maximum Output Current	$V_{IN} = 5V, 2.9V < V_{BAT} < 4.1V$	600mA $\pm 7\%$
Trickle Charge Current	$V_{IN} = 5V, V_{BAT} < 2.8V$	25-85mA
Prog/Monitor Voltage	$V_{IN} = 5V,$	1.6mV/mA

OPERATING PRINCIPLES

Demonstration circuit 654 implements a constant current, constant voltage charge algorithm suitable for Li-Ion batteries. Deeply discharged batteries are trickle charged at 10% of full charge rate. Once the battery voltage reaches 2.9V normal full rate charging will begin. Full charge current is set by the value of the resistor on the PROG pin of the LTC4057. In the event that full charge current would result in excessive temperature rise, due to some combination of input voltage, battery voltage, ambient temperature or PCB thermal characteristics, the LTC4057's

thermal loop will reduce charge current from the programmed value. Otherwise, programmed charge current will flow into the battery until the battery voltage begins to approach the final float value. As the battery reaches full charge the LTC4057 enters constant voltage mode, and the charge current begins to taper. The LTC4057 does not terminate the charging process and will remain in the float condition indefinitely. Charge termination is left to the user. Grounding the SHDN pin will terminate the charging cycle. Charge current information is provided to the user at the

QUICK START GUIDE FOR DEMONSTRATION CIRCUIT 654

LI-ION BATTERY CHARGER IN SOT23-6 WITH EXTERNAL TERMINATION

PROG pin. 100% charge current is 0V at 0% charge current. 1.00 volt, decreasing linearly to

QUICK START PROCEDURE

Demonstration circuit 654 is easy to set up to evaluate the performance of the LTC4057. Refer to Figure 1 for proper measurement equipment setup and follow the procedure below:

1. With power off, connect the input power supply, output load and meters as shown in Figure 1.

2. Turn on the power at the input.

NOTE: Make sure that the input voltage does not exceed 6.5V.

3. Set the Charger enable jumper (JP1) to ON

4. Vary the voltage on the simulated battery and note the charge current, and the voltage on the Prog pin.

5. Move the Charger enable jumper (JP1) to OFF to simulate an external termination signal.

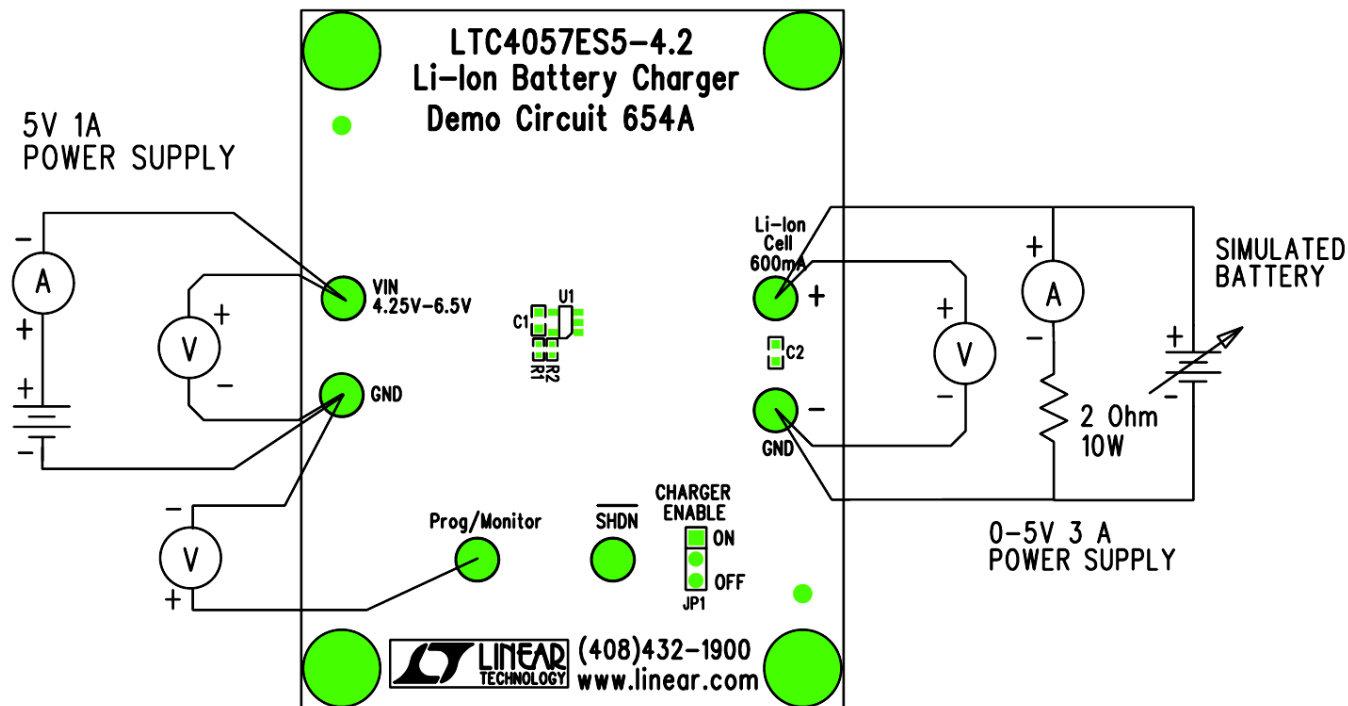

QUICK START GUIDE FOR DEMONSTRATION CIRCUIT 654

LI-ION BATTERY CHARGER IN SOT23-6 WITH EXTERNAL TERMINATION

Figure 1. Proper Measurement Equipment Setup

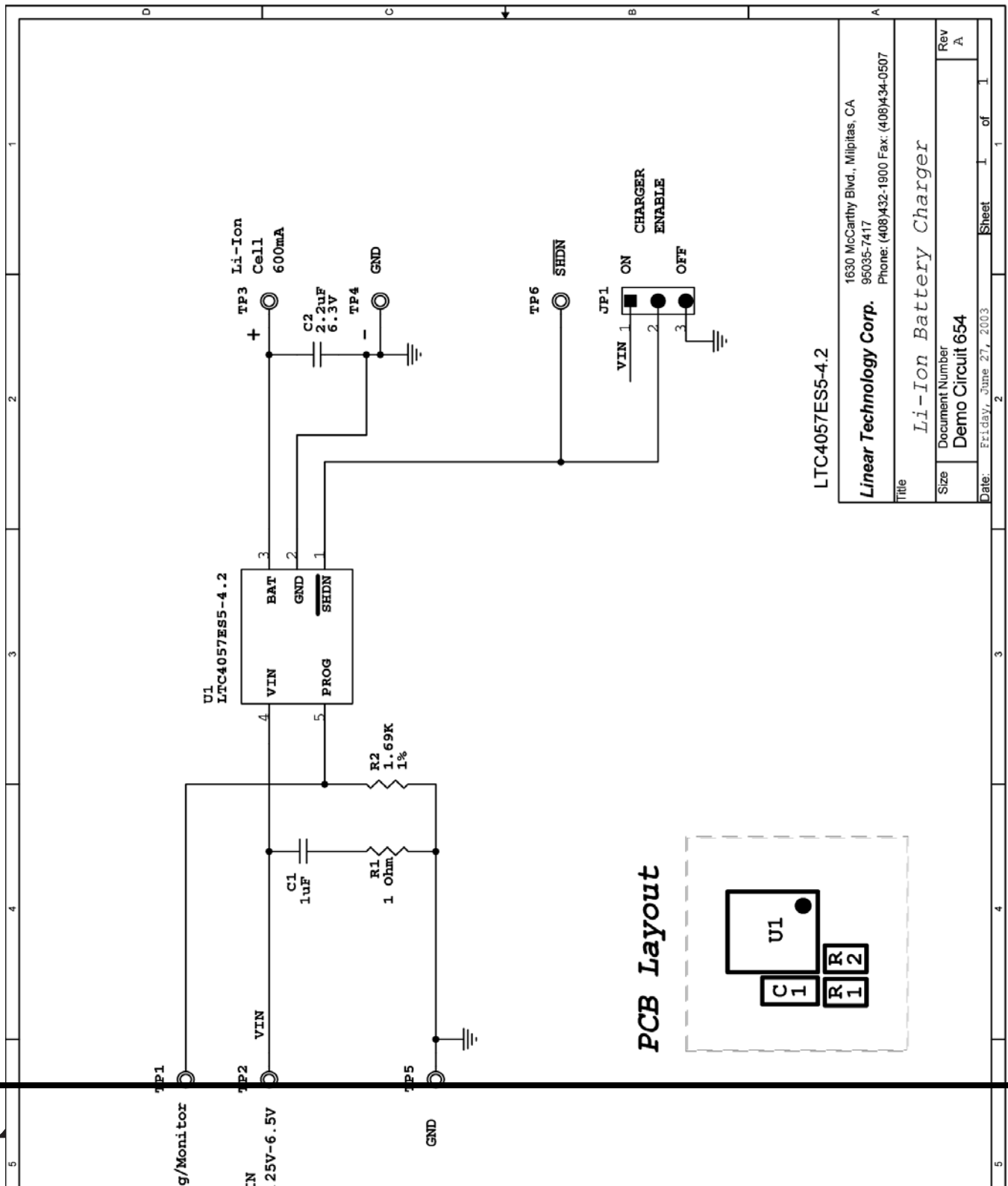

LTC4057ES5-4.2

1630 McCarthy Blvd., Milpitas, CA
95035-7417
Phone: (408)432-1900 Fax: (408)434-0507

Linear Technology Corp.

Title		Li-Ion Battery Charger	
Size	Document Number	Demo Circuit 654	
Date	Friday, June 27, 2003	Sheet	1 of 1
Rev	A		

QUICK START GUIDE FOR DEMONSTRATION CIRCUIT 654
LI-ION BATTERY CHARGER IN SOT23-6 WITH EXTERNAL TERMINATION

X-ON Electronics

Largest Supplier of Electrical and Electronic Components

Click to view similar products for [Power Management IC Development Tools](#) category:

Click to view products by [Analog Devices](#) manufacturer:

Other Similar products are found below :

[EVAL-ADM1168LQEBZ](#) [EVB-EP5348UI](#) [MIC23451-AAAYFL EV](#) [MIC5281YMME EV](#) [DA9063-EVAL](#) [ADP122-3.3-EVALZ](#) [ADP130-0.8-EVALZ](#) [ADP130-1.2-EVALZ](#) [ADP130-1.5-EVALZ](#) [ADP130-1.8-EVALZ](#) [ADP1714-3.3-EVALZ](#) [ADP1716-2.5-EVALZ](#) [ADP1740-1.5-EVALZ](#) [ADP1752-1.5-EVALZ](#) [ADP1828LC-EVALZ](#) [ADP1870-0.3-EVALZ](#) [ADP1871-0.6-EVALZ](#) [ADP1873-0.6-EVALZ](#) [ADP1874-0.3-EVALZ](#) [ADP1882-1.0-EVALZ](#) [ADP199CB-EVALZ](#) [ADP2102-1.25-EVALZ](#) [ADP2102-1.875EVALZ](#) [ADP2102-1.8-EVALZ](#) [ADP2102-2-EVALZ](#) [ADP2102-3-EVALZ](#) [ADP2102-4-EVALZ](#) [ADP2106-1.8-EVALZ](#) [ADP2147CB-110EVALZ](#) [AS3606-DB](#) [BQ24010EVM](#) [BQ24075TEVM](#) [BQ24155EVM](#) [BQ24157EVM-697](#) [BQ24160EVM-742](#) [BQ24296MEVM-655](#) [BQ25010EVM](#) [BQ3055EVM](#) [NCV891330PD50GEVB](#) [ISLUSBI2CKIT1Z](#) [LM2744EVAL](#) [LM2854EVAL](#) [LM3658SD-AEV/NOPB](#) [LM3658SDEV/NOPB](#) [LM3691TL-1.8EV/NOPB](#) [LM4510SDEV/NOPB](#) [LM5033SD-EVAL](#) [LP38512TS-1.8EV](#) [EVAL-ADM1186-1MBZ](#) [EVAL-ADM1186-2MBZ](#)