

## DESCRIPTION

Demonstration circuit 679 features the LT3463EDD in two circuits. One circuit is optimized for small size and the other for high performance. Both circuits are dual output  $\pm 20V$  voltage regulators. The positive regulator is a boost converter and the negative rail is an inverting charge pump. Refer to Tables 1 and 2 for details on performance.

The intended application of the DC679 is portable applications where reduced parts count, small circuit size and

high efficiency is important. The Burst Mode operation of the LT3463EDD allows for high efficiency over a broad range of loads and low quiescent current. Parts count is reduced by the integrated schottky diodes and the low current limit and low off time allows small inductors and capacitors to be used.

**Design files for this circuit board are available. Call the LTC factory.**

**Table 1. Performance Summary for the Small Size Circuit ( $T_A = 25^\circ C$ )**

PARAMETER	CONDITION	VALUE
Input voltage range		2.7V to 6.0V
$ V_{OUT} $ (both rails)	0mA to $I_{OUT(MAX)}$	20V $\pm 4\%$
$I_{OUT(MAX)}$ (both rails)	$V_{IN} = 2.7V$	5mA
	$V_{IN} = 3.6V$	7mA
	$V_{IN} = 5.0V$	9mA
Typical Output Ripple (+20V)	$V_{IN} = 3.6V, I_{OUT} = 7mA$	130mV p-p
Typical Output Ripple (-20V)	$V_{IN} = 3.6V, I_{OUT} = 7mA$	140mV p-p
Typical Efficiency (+20V)	$V_{IN} = 3.6V, I_{OUT} = 7mA, -20V$ rail not enabled	74%
Typical Efficiency (-20V)	$V_{IN} = 3.6V, I_{OUT} = 7mA, +20V$ rail not enabled	74%
Typical no load input current (both rails)	$V_{IN} = 3.6V$	140uA

**Table 2. Performance Summary for the High Performance Circuit ( $T_A = 25^\circ C$ )**

PARAMETER	CONDITION	VALUE
Input voltage range		2.7V to 6.0V
$ V_{OUT} $ (both rails)	0mA to $I_{OUT(MAX)}$	20V $\pm 4\%$
$I_{OUT(MAX)}$ (both rails)	$V_{IN} = 2.7V$	7mA
	$V_{IN} = 3.6V$	9mA
	$V_{IN} = 5.0V$	13mA
Typical Output Ripple (+20V)	$V_{IN} = 3.6V, I_{OUT} = 9mA$	105mV p-p
Typical Output Ripple (-20V)	$V_{IN} = 3.6V, I_{OUT} = 9mA$	105mV p-p
Typical Efficiency (+20V)	$V_{IN} = 3.6V, I_{OUT} = 9mA, -20V$ rail not enabled	76%
Typical Efficiency (-20V)	$V_{IN} = 3.6V, I_{OUT} = 9mA, +20V$ rail not enabled	76%
Typical no load input current (both rails)	$V_{IN} = 3.6V$	140uA

## QUICK START PROCEDURE

Demonstration circuit 679 is easy to set up to evaluate the performance of the LT3463EDD. Refer to Figure 1 for proper measurement equipment setup and follow the procedure below:

**NOTE:** When measuring the input or output voltage ripple, care must be taken to avoid a long ground lead on the oscilloscope probe. Measure the input or output voltage ripple by touching the probe tip directly across the Vin or Vout and GND terminals. See Figure 2 for proper scope probe technique.

1. Make sure the  $\overline{\text{SHDN}}$  pins are in the ON position.
2. Turn on the input voltage source and set it to 3.6V.
3. Monitor the output voltage.  $|\text{VOUT}|$  for both the positive and negative rails of the small size and high performance circuits should be  $20\text{V} \pm 4\%$ .
4. Apply the full rated load to the outputs for an input voltage of 3.6V. For the small size circuit this is 7mA and for the high performance circuit this is 9mA. The rails should still be within regulation.
5. With full rated load applied and with the input voltage still at 3.6V, measure the input current. For the small size circuit, the input current should be less than 140mA and for the high performance circuit, the input current should be less than 150mA.
6. Once the proper output voltages are established, adjust the loads within the operating range and observe the output voltage regulation, ripple voltage and other parameters.

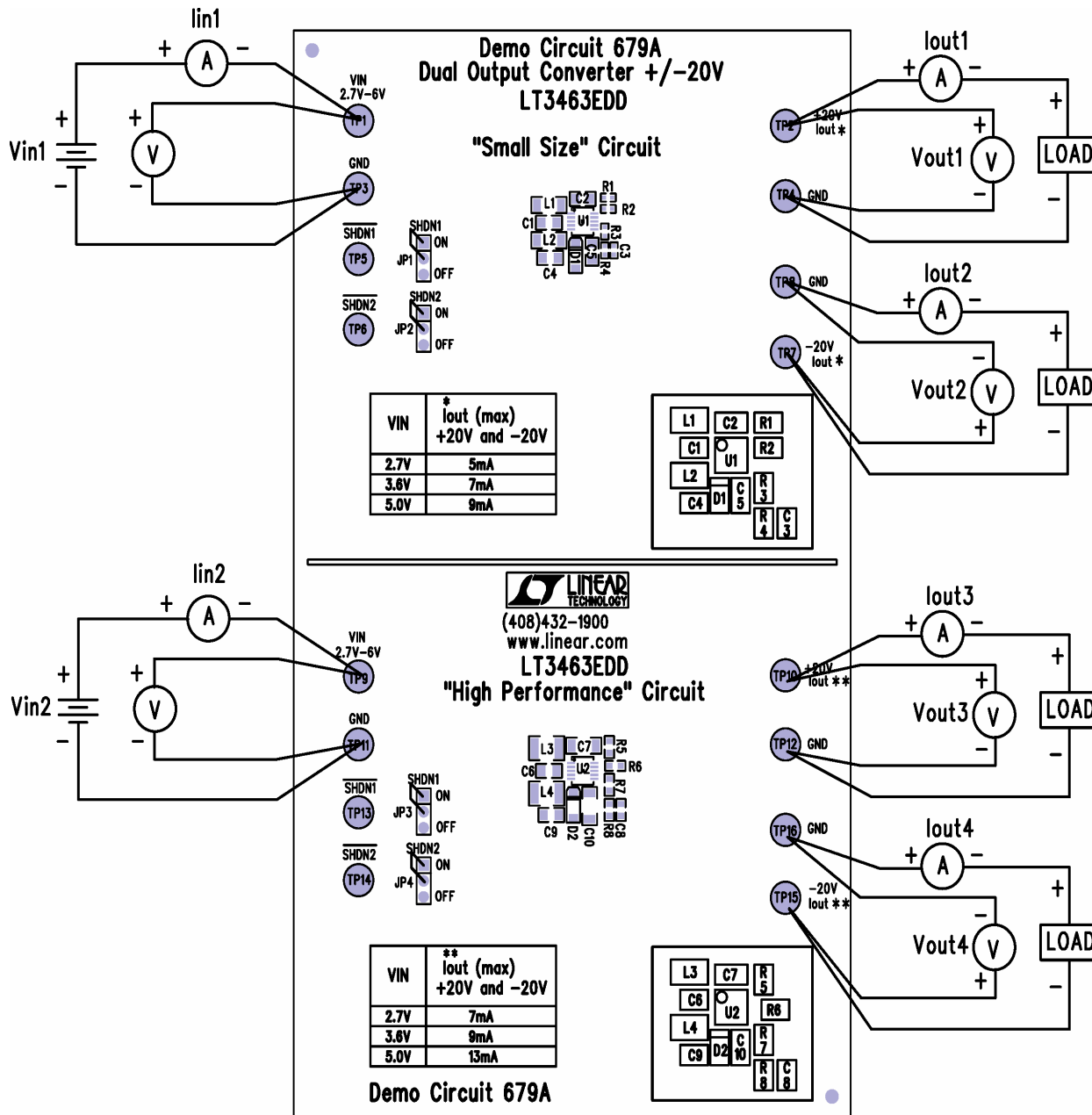

Figure 1. Proper Measurement Equipment Setup

# QUICK START GUIDE FOR DC679 DUAL OUTPUT CONVERTER

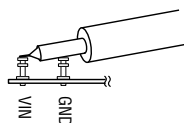
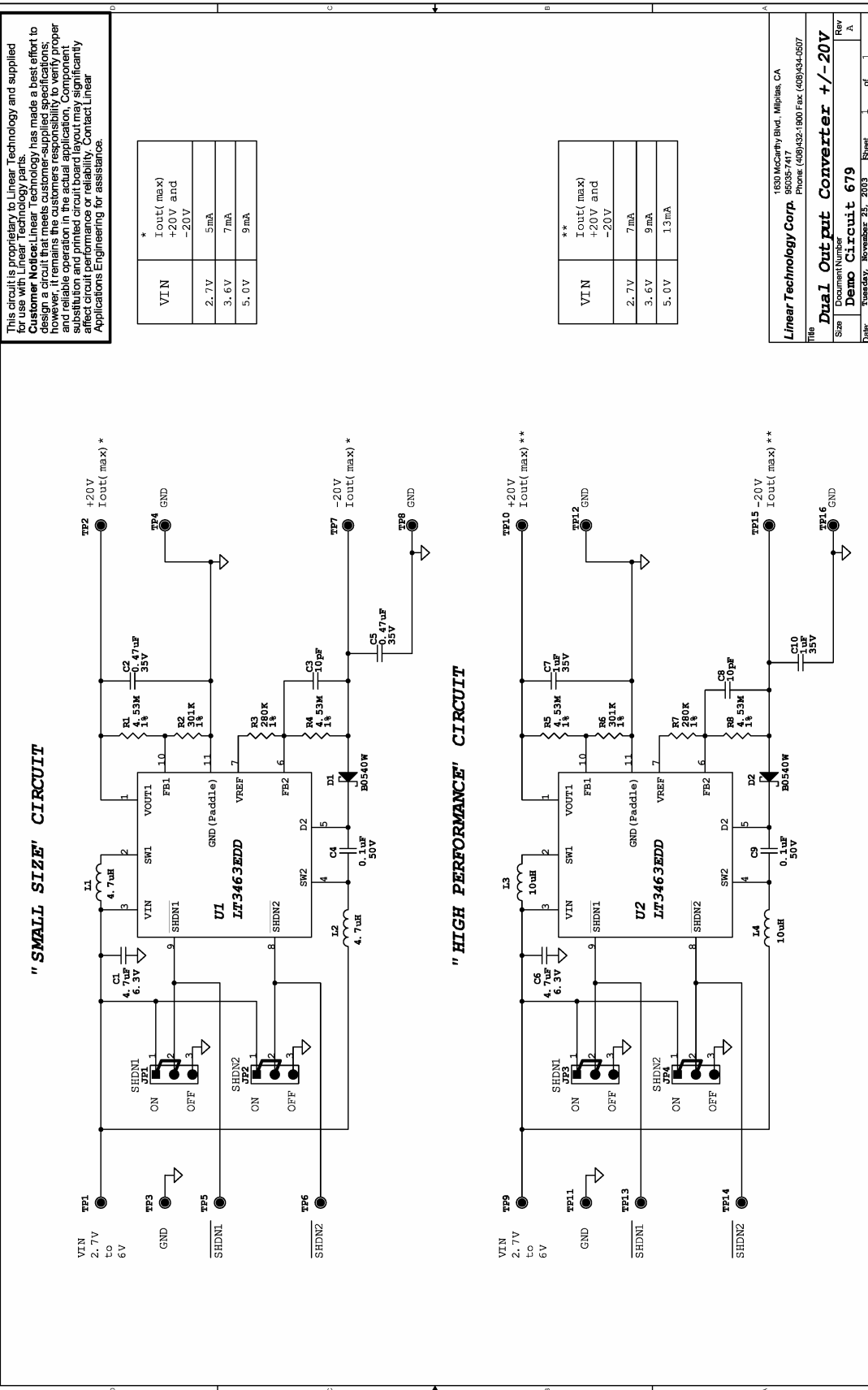

Figure 2. Measuring Input or Output Ripple

<i>Item</i>	<i>Qty</i>	<i>Reference</i>	<i>Part Description</i>	<i>Manufacture / Part #</i>
1	2	C6,C1	Cap., X5R 4.7uF 6.3V 20%	Taiyo Yuden JMK212BJ475MG-T
2	2	C5,C2	Cap., X5R .47uF 35V 20%	Taiyo Yuden GMK212BJ474MG-T
3	1	C3	Cap., NPO 10pF 50V 10%	AVX 04025A100KAT2A
4	2	C9,C4	Cap., X7R 0.1uF 50V 10%	Taiyo Yuden UMK212BJ104KG
5	2	C7,C10	Cap., X7R 1uF 35V 10%	Taiyo Yuden GMK316BJ105KL
6	1	C8	Cap., NPO 10pF 50V 10%	AVX 06035A100KAT2A
7	2	D1,D2	Diode Schotkky, 40V	Diodes Inc. B0540W
8	4	JP1,JP2,JP3,JP4	Headers, 3 Pins 2mm Ctrs.	CommConn Con. Inc. 2802S-03G2
9	4	XJP1-XJP4	Shunt, 2 Pins 2mm Ctrs.	CommConn Con. Inc. CCIJ2MM-138GW
10	2	L1,L2	Inductor, 4.7uH 340mA 0.65 Ohm 20%	muRata LQH31CN4R7M03L
11	2	L3,L4	Inductor, 10uH 300mA 0.42 Ohm 20%	muRata LQH32CN100M53
12	2	R4,R1	Res., Chip 4.53M 1/16W 1%	AAC CR05-4534FM
13	1	R2	Res., Chip 301K 0.06W 1%	AAC CR05-3013FM
14	1	R3	Res., Chip 280K 0.06W 1%	AAC CR05-2803FM
15	2	R8,R5	Res., Chip 4.53M 0.06w 1%	AAC CR16-4534FM
16	1	R6	Res., Chip 301K 0.06W 1%	AAC CR16-3013FM
17	1	R7	Res., Chip 280K 0.1W 1%	AAC CR16-2803FM
18	16	TP1-TP16	Turret, Testpoint	Mill Max 2501-2
19	2	U1,U2	I.C., Dual uPower Boost Converter	Linear Tech. Corp. LT3463EDD
20	1		PRINTED CIRCUIT BOARD	DEMO CIRCUIT 679A
21	1		STENCIL	STENCIL # 679A

# QUICK START GUIDE FOR DC679 DUAL OUTPUT CONVERTER



This circuit is proprietary to Linear Technology and supplied for use with Linear Technology parts.  
**Customer Notice:** Linear Technology has made a best effort to design a circuit that meets customer-supplied specifications. However, the user is responsible for verifying the circuit meets their specifications and reliable operation in the actual application. Component substitution and printed circuit board layout may significantly affect circuit performance or reliability. Contact Linear Applications Engineering for assistance.

VIN	Iout(max) +20V and -20V
2.7V	5mA
3.6V	7mA
5.0V	9mA

VIN	Iout(max) +20V and -20V
2.7V	7mA
3.6V	9mA
5.0V	13mA

Linear Technology Corp. 1630 McCarty Blvd, Milpitas, CA 95035-7417  
 Phone: (408)432-1900 Fax: (408)434-0507

**Dual Output Converter +/- 20V**  
 Demo Circuit 679

Title: \_\_\_\_\_  
 Size: \_\_\_\_\_  
 Document Number: \_\_\_\_\_  
 Date: Tuesday, November 25, 2003 \_\_\_\_\_

## X-ON Electronics

Largest Supplier of Electrical and Electronic Components

*Click to view similar products for [Power Management IC Development Tools](#) category:*

*Click to view products by [Analog Devices](#) manufacturer:*

Other Similar products are found below :

[EVAL-ADM1168LQEBZ](#) [EVB-EP5348UI](#) [MIC23451-AAAYFL EV](#) [MIC5281YMME EV](#) [DA9063-EVAL](#) [ADP122-3.3-EVALZ](#) [ADP130-0.8-EVALZ](#) [ADP130-1.2-EVALZ](#) [ADP130-1.5-EVALZ](#) [ADP130-1.8-EVALZ](#) [ADP1714-3.3-EVALZ](#) [ADP1716-2.5-EVALZ](#) [ADP1740-1.5-EVALZ](#) [ADP1752-1.5-EVALZ](#) [ADP1828LC-EVALZ](#) [ADP1870-0.3-EVALZ](#) [ADP1871-0.6-EVALZ](#) [ADP1873-0.6-EVALZ](#) [ADP1874-0.3-EVALZ](#) [ADP1882-1.0-EVALZ](#) [ADP199CB-EVALZ](#) [ADP2102-1.25-EVALZ](#) [ADP2102-1.875EVALZ](#) [ADP2102-1.8-EVALZ](#) [ADP2102-2-EVALZ](#) [ADP2102-3-EVALZ](#) [ADP2102-4-EVALZ](#) [ADP2106-1.8-EVALZ](#) [ADP2147CB-110EVALZ](#) [AS3606-DB](#) [BQ24010EVM](#) [BQ24075TEVM](#) [BQ24155EVM](#) [BQ24157EVM-697](#) [BQ24160EVM-742](#) [BQ24296MEVM-655](#) [BQ25010EVM](#) [BQ3055EVM](#) [NCV891330PD50GEVB](#) [ISLUSBI2CKIT1Z](#) [LM2744EVAL](#) [LM2854EVAL](#) [LM3658SD-AEV/NOPB](#) [LM3658SDEV/NOPB](#) [LM3691TL-1.8EV/NOPB](#) [LM4510SDEV/NOPB](#) [LM5033SD-EVAL](#) [LP38512TS-1.8EV](#) [EVAL-ADM1186-1MBZ](#) [EVAL-ADM1186-2MBZ](#)