

DESCRIPTION

Demonstration circuit 690 is a DC-DC flyback converter using the LT3420EMS-1 to rapidly charge an output capacitor to 300V for photoflash applications. It demonstrates a simple application circuit operating in high efficiency and shows appropriate layout techniques for the LT3420EMS-1. The circuit uses small surface mount components and has very small board space compared to conventional solutions. This demonstration circuit is particularly useful for applications such as digital cam-

eras and high voltage supplies that require high efficiency and small size.

Design files for this circuit board are available. Call the LTC factory.

LT is a trademark of Linear Technology Corporation

QUICK START PROCEDURE

Demonstration circuit 690 is easy to set up to evaluate the performance of the LT3420EMS-1. Refer to Figure 1 for proper measurement equipment setup and follow the procedure below:

NOTE: When measuring the input or output voltage ripple, care must be taken to avoid a long ground lead on the oscilloscope probe. Measure the input or output voltage ripple by touching the probe tip directly across the Vin or Vout and GND terminals. See Figure 2 for proper scope probe technique.

NOTE: For safe operation, always shield the circuit when power is on, and always discharge the high voltage output capacitor after power is off.

1. With power off, connect input power source Vbatt to the Vbatt and GND terminals. Input voltage is limited to between 1.8V to 6V.
2. Set JP1 to DISCONNECT position for separate input power operation. Connect input power source Vcc to the Vcc and GND terminals, and limit the input voltage from 2.3V to 6V.
3. Connect load (a 70uF, 330V photoflash capacitor) between the +Strobe Cap and -Strobe Cap terminals.
4. Set JP2 to ON position to enable Charge operation.

5. Slowly turn on power source Vbatt and Vcc. Check for the proper output voltages. Vout= 320V.

NOTE: If there is no output, temporarily disconnect the load and input power source, and make sure that JP2 is set to ON position.

6. Measure the charge time (Vout rise time from 0V to 320V) from scope, it should be about 3 seconds. The photoflash capacitor should be pre-charged a few times before the measurement test due to its memory characteristic.
7. For efficiency measurement, connect a high voltage adjustable load box between the +Strobe Cap and -Strobe Cap terminals, adjust load and set the Vout = 300V. Measure the Vin, Iin, Vout and Iout and calculate the efficiency. For Vin=3.3V, the efficiency should be above 70%.
8. For single source operation, set the input source selector Jumper JP1 to CONNECT position. Remove the connection of power source Vcc. Limit the input voltage from 2.3V to 6V. Vcc will be powered from Vbatt.
9. To shut down the circuit, connect the JP2 to OFF position. The output capacitor charging is disabled.

Warning: Operate by high voltage trained personnel only.

QUICK START GUIDE FOR DEMONSTRATION CIRCUIT DC690

STROBE CAPACITOR CHARGER, HIGH VOLTAGE SUPPLY

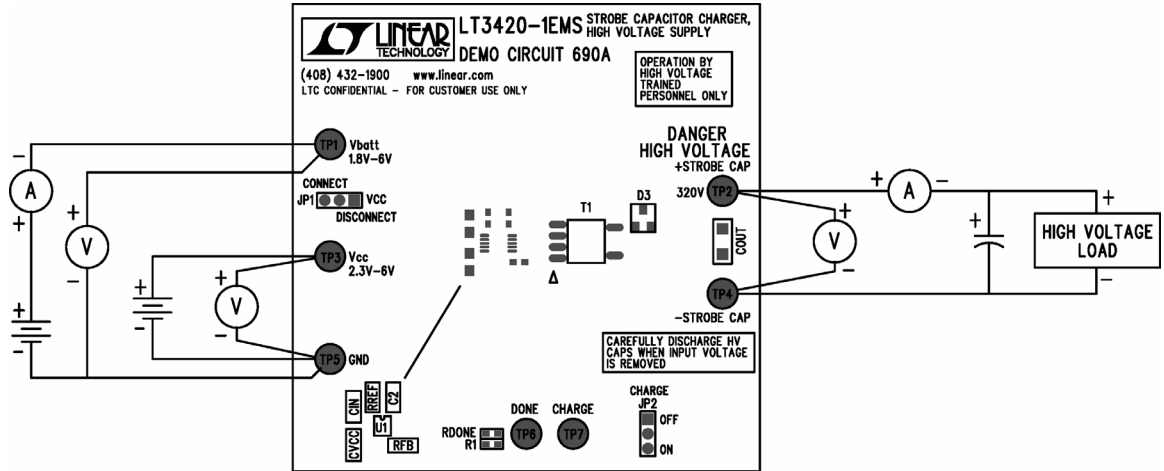

Figure 1. Proper Measurement Equipment Setup

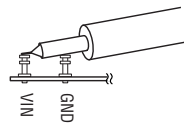

Figure 2. Measuring Input or Output Ripple

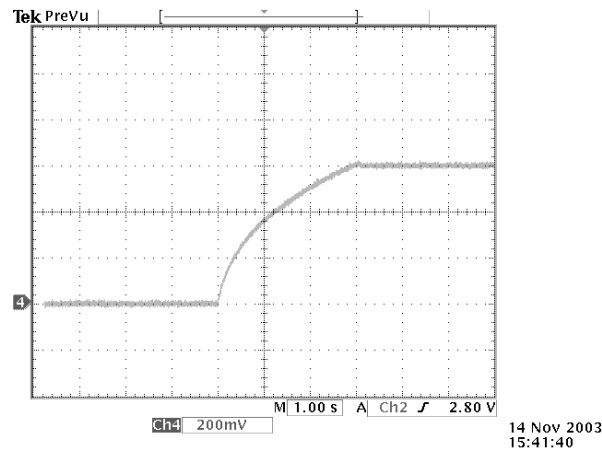

Figure 3. Charge time for charging 70uF, 330V photoflash capacitor. CH4: Vout, 100V/Div. Vin=3.3V, Vout=300V.

QUICK START GUIDE FOR DEMONSTRATION CIRCUIT DC690

STROBE CAPACITOR CHARGER, HIGH VOLTAGE SUPPLY

2

REVISION HISTORY				
ECO	REV	DESCRIPTION	DATE	APPROVED
	1	PROTO	06/06/03	

This circuit is proprietary to Linear Technology and supplied for use with Linear Technology parts.
Customer Notice: Linear Technology has made a best effort to design a circuit that meets customer-supplied specifications; however, it remains the customer's responsibility to verify proper and reliable operation in the actual application. Component substitution and printed circuit board layout may significantly affect circuit performance or reliability. Contact Linear Applications Engineering for assistance.

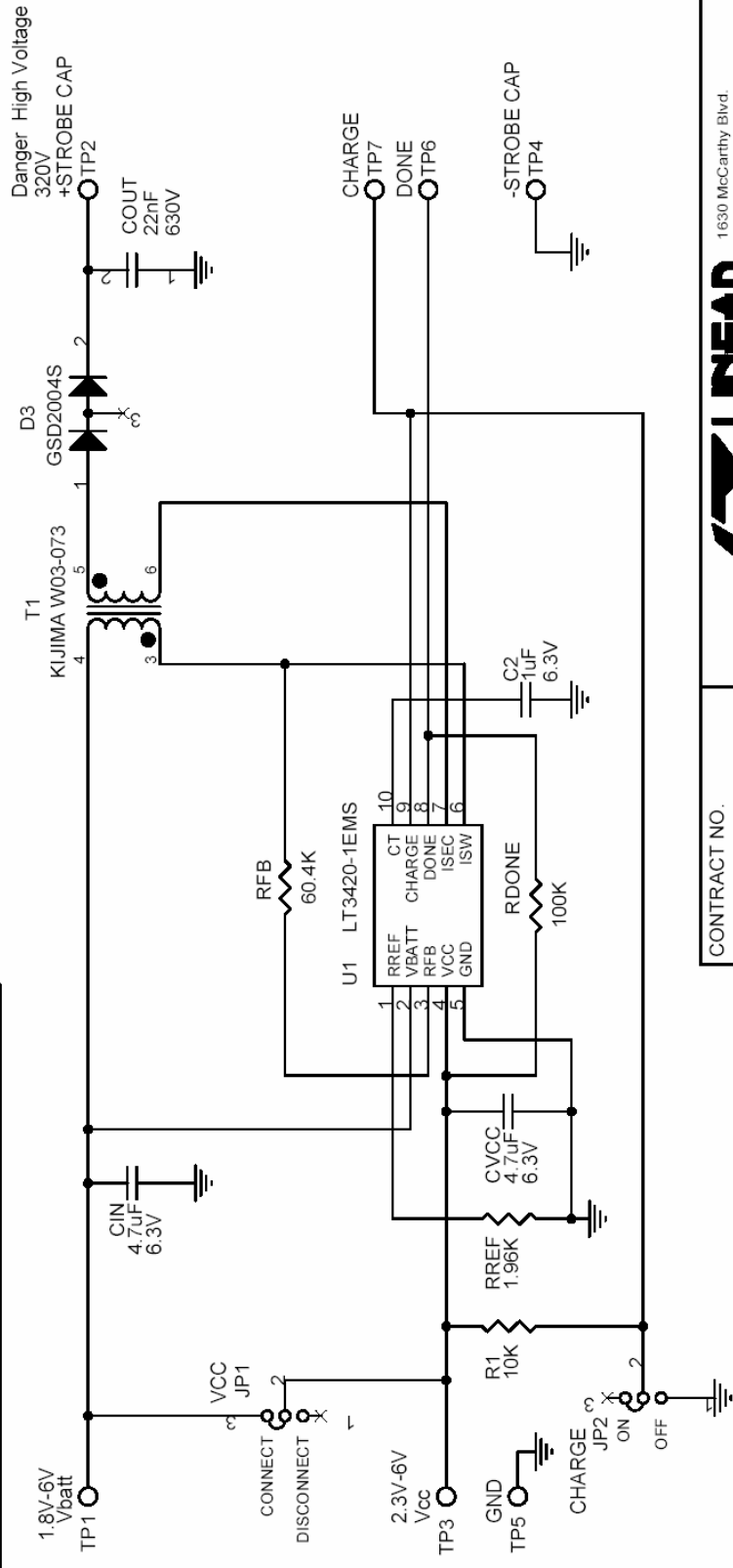

CONTRACT NO.		1630 McCarthy Blvd. Milpitas, CA 95035 Phone: (408)432-1900 Fax: (408)434-0907	
APPROVALS	DATE	TITLE	
DRAWN: MEI	06/06/03	SCH1 LT3420-1EMS STROBE CAPACITOR CHARGER HIGH VOLTAGE SUPPLY	
CHECKED		SIZE	DWG NO
APPROVED			DC690A
ENGINEER		SCALE:	FILENAME: 690A-2.DSN
DESIGNER			SHEET 1 OF 1
Wednesday, October 29, 2003			

LTC CONFIDENTIAL - For Customer Use Only

2



X-ON Electronics

Largest Supplier of Electrical and Electronic Components

Click to view similar products for [Power Management IC Development Tools](#) category:

Click to view products by [Analog Devices](#) manufacturer:

Other Similar products are found below :

[EVAL-ADM1168LQEBZ](#) [EVB-EP5348UI](#) [MIC23451-AAAYFL EV](#) [MIC5281YMME EV](#) [DA9063-EVAL](#) [ADP122-3.3-EVALZ](#) [ADP130-0.8-EVALZ](#) [ADP130-1.2-EVALZ](#) [ADP130-1.5-EVALZ](#) [ADP130-1.8-EVALZ](#) [ADP1714-3.3-EVALZ](#) [ADP1716-2.5-EVALZ](#) [ADP1740-1.5-EVALZ](#) [ADP1752-1.5-EVALZ](#) [ADP1828LC-EVALZ](#) [ADP1870-0.3-EVALZ](#) [ADP1871-0.6-EVALZ](#) [ADP1873-0.6-EVALZ](#) [ADP1874-0.3-EVALZ](#) [ADP1882-1.0-EVALZ](#) [ADP199CB-EVALZ](#) [ADP2102-1.25-EVALZ](#) [ADP2102-1.875EVALZ](#) [ADP2102-1.8-EVALZ](#) [ADP2102-2-EVALZ](#) [ADP2102-3-EVALZ](#) [ADP2102-4-EVALZ](#) [ADP2106-1.8-EVALZ](#) [ADP2147CB-110EVALZ](#) [AS3606-DB](#) [BQ24010EVM](#) [BQ24075TEVM](#) [BQ24155EVM](#) [BQ24157EVM-697](#) [BQ24160EVM-742](#) [BQ24296MEVM-655](#) [BQ25010EVM](#) [BQ3055EVM](#) [NCV891330PD50GEVB](#) [ISLUSBI2CKIT1Z](#) [LM2744EVAL](#) [LM2854EVAL](#) [LM3658SD-AEV/NOPB](#) [LM3658SDEV/NOPB](#) [LM3691TL-1.8EV/NOPB](#) [LM4510SDEV/NOPB](#) [LM5033SD-EVAL](#) [LP38512TS-1.8EV](#) [EVAL-ADM1186-1MBZ](#) [EVAL-ADM1186-2MBZ](#)