

## DESCRIPTION

Demonstration circuit 692 is a high efficiency 1.2MHz boost DC/DC converter featuring the LTC3426ES6. The board is capable of supplying 400mA current from 1.8V to 4.2V input with a 5V output. It can deliver 5V at 800mA from a 3.3V input. The converter has internal soft start and internal frequency compensation features. The LTC3426 chip is in a low profile (1mm) SOT-23 package and has very low shutdown current of about 0.5 $\mu$ A.

A switching frequency of 1.2MHz allows a tiny solution footprint. Typical applications include local 3.3V or 5V supply, battery back-up, portable devices and white LED driver supply.

**Design files for this circuit board are available. Call the LTC factory.**

LTC is a trademark of Linear Technology Corporation

**Table 1. Performance Summary**

PARAMETER	CONDITION	VALUE
Maximum Load Current, Min	Vout = 5V, Vin = 1.8V	400mA
Maximum Load Current, Min	Vout = 5V, Vin = 3.3V	800mA
Switching Frequency, Typ		1.2MHz
Efficiency, Typ	Vout = 5V, Vin = 3.3V, Iout = 800mA	87%
Output Ripple, Typ	Vout = 5V, VIN = 3.3V, IOUT = 400mA (20MHz BW)	90mVp-p

## QUICK START PROCEDURE

Demonstration circuit 692 is easy to set up to evaluate the performance of the LTC3426. Refer to Figure 1 for proper measurement equipment setup and follow the procedure below:

**NOTE:** When measuring the input or output voltage ripple, care must be taken to avoid a long ground lead on the oscilloscope probe. Measure the input or output voltage ripple by touching the probe tip directly across the Vin or Vout and GND terminals. See Figure 2 for proper scope probe technique.

1. Place the jumper in the following position:

**JP1**    On

2. With power off, connect the input power supply (1.8V-4.2V) to Vin and GND. Connect the load to Vout and GND. Set initial load = 0A (no load).

3. Turn on the power at the input.
4. Check for the output voltage. Vout should be 5V $\pm$ 0.2V.
5. Once the proper output voltage is established, adjust the load within the operating range and observe the output voltage regulation, ripple voltage, efficiency and other parameters.

**NOTE:** If there is no output, temporarily disconnect the load to make sure that the load is not set too high. The available output current depends on the input voltage. The output diode is rated for 1A current.

# QUICK START GUIDE FOR DEMONSTRATION CIRCUIT 692

## 1.2MHz HIGH CURRENT BOOST CONVERTER

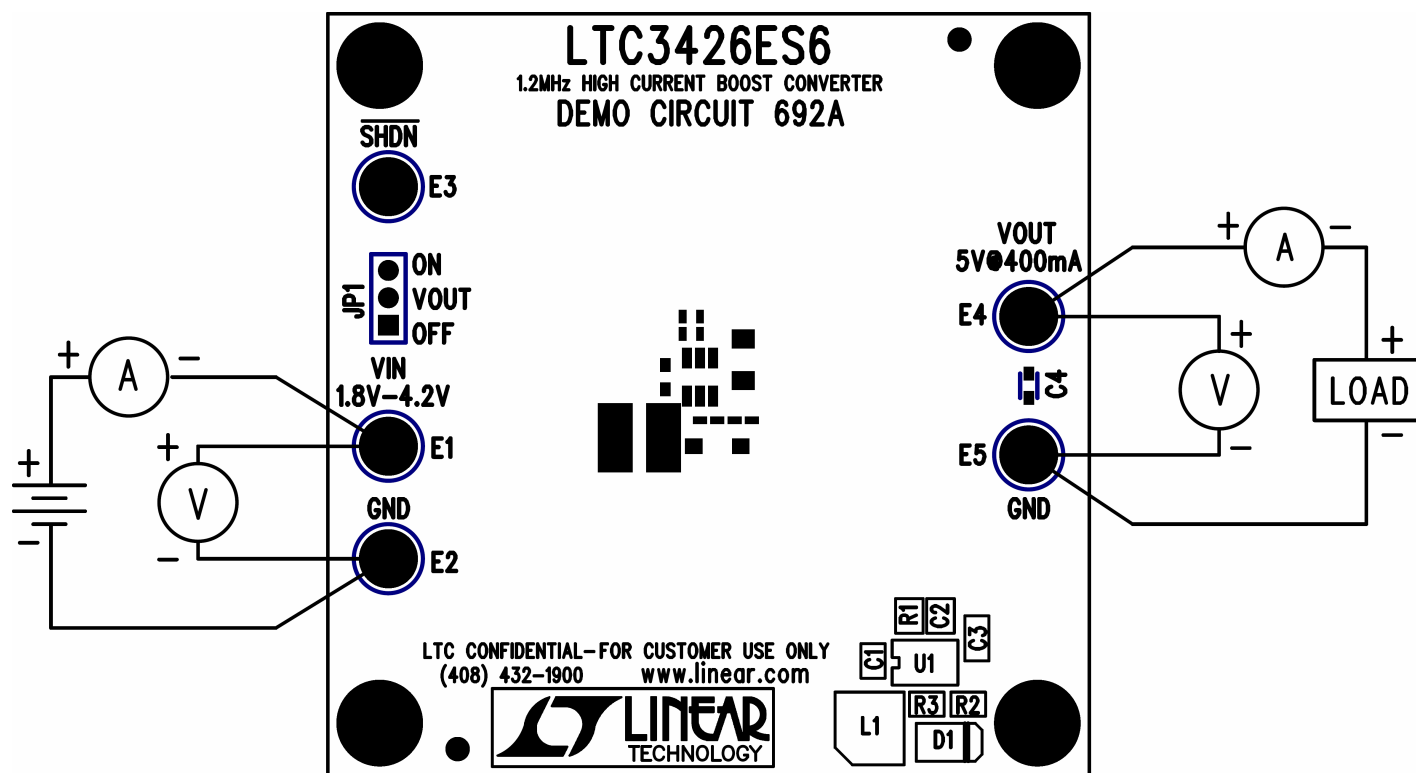

Figure 1. Proper Measurement Equipment Setup

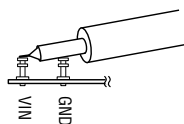
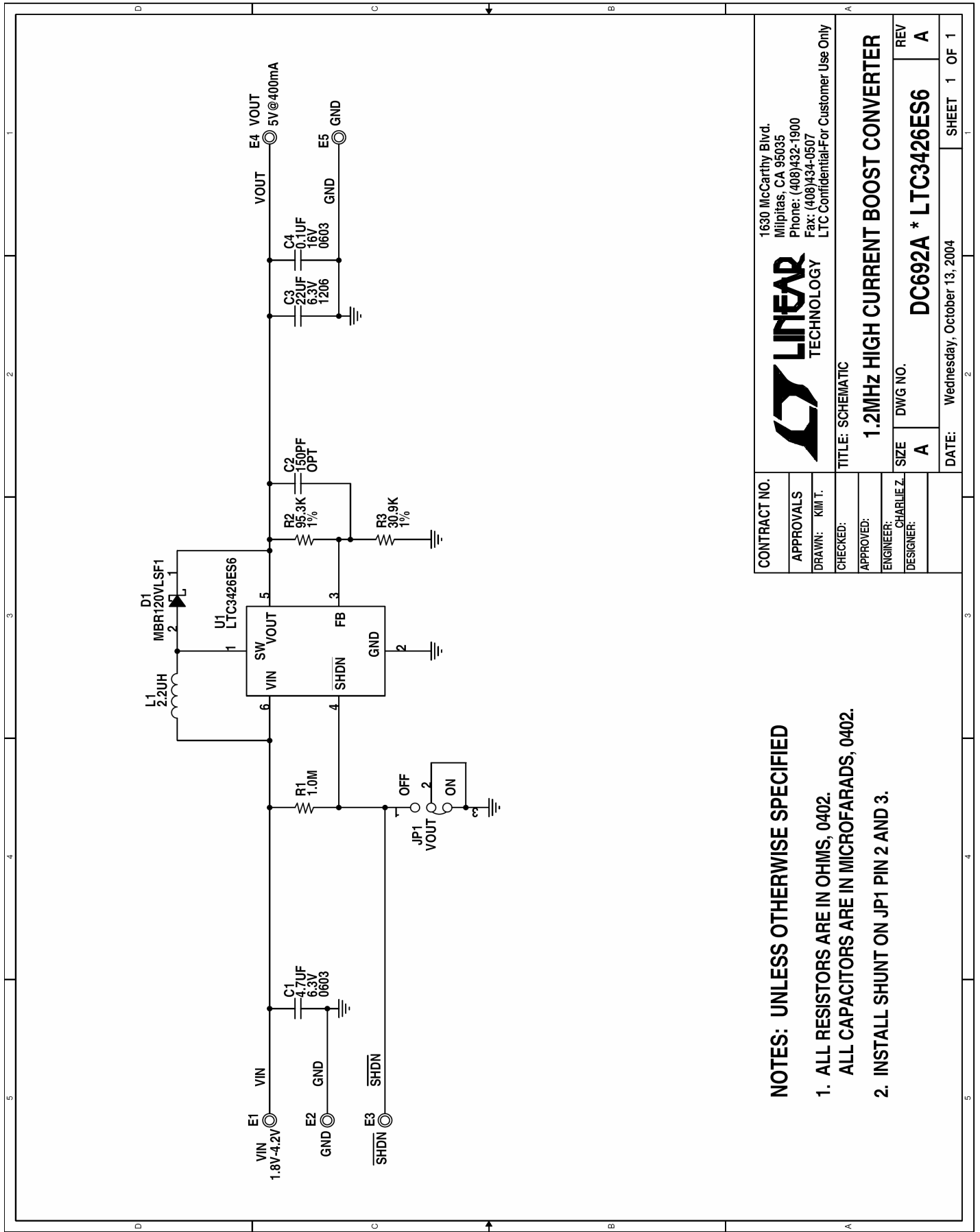

Figure 2. Measuring Input or Output Ripple

# QUICK START GUIDE FOR DEMONSTRATION CIRCUIT 692

## 1.2MHZ HIGH CURRENT BOOST CONVERTER



- NOTES: UNLESS OTHERWISE SPECIFIED**
1. ALL RESISTORS ARE IN OHMS, 0402.
  2. ALL CAPACITORS ARE IN MICROFARADS, 0402.
  3. INSTALL SHUNT ON JP1 PIN 2 AND 3.

<b>CONTRACT NO.</b>		<b>LINEAR TECHNOLOGY</b>		1630 McCarthy Blvd. Milpitas, CA 95035 Phone: (408)432-1900 Fax: (408)434-0507 LTC Confidential-For Customer Use Only	
<b>APPROVALS</b>		<b>TITLE: SCHEMATIC</b>		<b>1.2MHZ HIGH CURRENT BOOST CONVERTER</b>	
<b>DRAWN:</b> KIM T.	<b>CHECKED:</b>	<b>SIZE</b> A	<b>DWG NO.</b>	<b>REV</b> A	<b>REV</b> A
<b>APPROVED:</b>	<b>ENGINEER:</b> CHARLIE Z.	<b>DESIGNER:</b>	<b>DC692A * LTC3426ES6</b>	<b>DATE:</b> Wednesday, October 13, 2004	<b>SHEET</b> 1 OF 1

## X-ON Electronics

Largest Supplier of Electrical and Electronic Components

*Click to view similar products for [Power Management IC Development Tools](#) category:*

*Click to view products by [Analog Devices](#) manufacturer:*

Other Similar products are found below :

[EVAL-ADM1168LQEBZ](#) [EVB-EP5348UI](#) [MIC23451-AAAYFL EV](#) [MIC5281YMME EV](#) [DA9063-EVAL](#) [ADP122-3.3-EVALZ](#) [ADP130-0.8-EVALZ](#) [ADP130-1.2-EVALZ](#) [ADP130-1.5-EVALZ](#) [ADP130-1.8-EVALZ](#) [ADP1714-3.3-EVALZ](#) [ADP1716-2.5-EVALZ](#) [ADP1740-1.5-EVALZ](#) [ADP1752-1.5-EVALZ](#) [ADP1828LC-EVALZ](#) [ADP1870-0.3-EVALZ](#) [ADP1871-0.6-EVALZ](#) [ADP1873-0.6-EVALZ](#) [ADP1874-0.3-EVALZ](#) [ADP1882-1.0-EVALZ](#) [ADP199CB-EVALZ](#) [ADP2102-1.25-EVALZ](#) [ADP2102-1.875EVALZ](#) [ADP2102-1.8-EVALZ](#) [ADP2102-2-EVALZ](#) [ADP2102-3-EVALZ](#) [ADP2102-4-EVALZ](#) [ADP2106-1.8-EVALZ](#) [ADP2147CB-110EVALZ](#) [AS3606-DB](#) [BQ24010EVM](#) [BQ24075TEVM](#) [BQ24155EVM](#) [BQ24157EVM-697](#) [BQ24160EVM-742](#) [BQ24296MEVM-655](#) [BQ25010EVM](#) [BQ3055EVM](#) [NCV891330PD50GEVB](#) [ISLUSBI2CKIT1Z](#) [LM2744EVAL](#) [LM2854EVAL](#) [LM3658SD-AEV/NOPB](#) [LM3658SDEV/NOPB](#) [LM3691TL-1.8EV/NOPB](#) [LM4510SDEV/NOPB](#) [LM5033SD-EVAL](#) [LP38512TS-1.8EV](#) [EVAL-ADM1186-1MBZ](#) [EVAL-ADM1186-2MBZ](#)