

DESCRIPTION

Demonstration circuit 696 with LT5546 IC is a 40MHz to 500MHz monolithic integrated quadrature demodulator with variable gain amplifier (VGA), designed for low voltage operation. It supports standards that use linear modulation format. The chip consists of a VGA, quadrature down-converting mixers and 17MHz lowpass noise filters. The LO port consists of a divide-by-two stage and LO buffers. The IC provides all building blocks for IF down-conversion to I and Q baseband signals with a single supply voltage of 1.8V to 5.25V. The VGA gain has a linear-in-dB relationship to the control input voltage. Hard-clipping amplifiers at the mixer outputs reduce the recovery time from a signal overload condition. The lowpass filters

reduce the out-of-band noise and spurious frequency components. The -3dB corner frequency of the noise filters is approximately 17MHz. The external 2XLO frequency is required to be twice the IF input frequency for the mixers. The standby mode provides reduced supply current and fast transient response into the normal operating mode when the I/Q outputs are AC-coupled to a baseband chip.

Design files for this circuit board are available. Call the LTC factory.

LT is a trademark of Linear Technology Corporation

Table 1. Dip-Switch Setting For Different Operating Modes

EN	STBY	COMMENTS
Low	Low	Shutdown Mode
Low	High	Standby Mode
High	Low or High	Normal Operation Mode

DC POWER CONSUMPTION MEASUREMENTS

- 1) Connect test equipment and power supplies to the demo board as shown in Figure 1.
- 2) Set Power Supply #1 and Power Supply #2 to +3.0V.
NOTE: One Power Supply can be used as well.
- 3) Set Power Supply #3 Between +4.75V and +5.25V. This is the voltage source for the two Op-Amps U2 and U3.
- 4) Set Power Supply #4 to 0V (minimum gain).
- 5) Shutdown Mode
 - a) Set dipswitches for EN and STBY to “On” (Logic Low).
 - b) Measure Current in Vcc1. It should be approximately 0.2 μA .
- 6) Standby Mode
 - a) Set EN dipswitch to “On” position (Logic Low).
 - b) Set STBY dipswitch to “Off” position (Logic High).
 - c) Measure Current in Vcc1. It should be approximately 3.6mA.
- 7) Normal Operation Mode
 - a) Set EN dipswitch to “Off” position (Logic High).
 - b) Set STBY dipswitch to either “On” or “Off”.
 - c) Measure Current in Vcc1. It should be approximately 27mA.

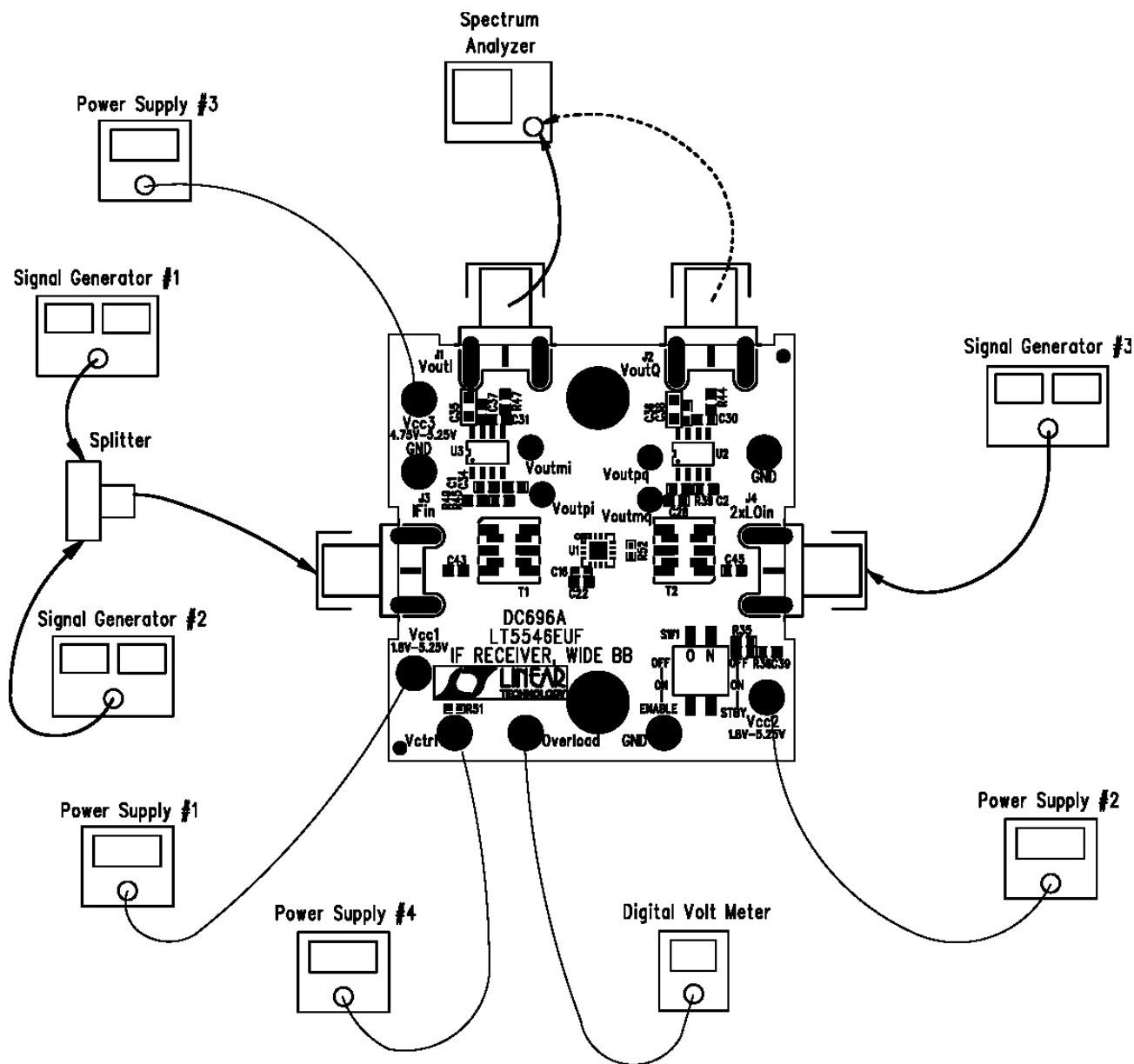

Figure 1. Test and Measurement Setup

TOTAL HARMONIC DISTORTION MEASUREMENTS

- 1) Use setting steps 1 to 4 from previous DC power consumption measurements.
 - 2) Set dipswitch of EN and STBY to “Off “ position (Logic High). The IC is in Normal Operation Mode.
 - 3) Set Signal Generator # 1 for $f_{IF}=280.0\text{MHz}$, CW mode, with $P_{IF} = -40\text{dBm}$.
 - 4) Set Signal Generator # 2 for $f_{IF} = 280.1\text{MHz}$, CW mode, with $P_{IF} = -40\text{dBm}$.
 - 5) Set Signal Generator # 3 for $f_{LO}=570\text{MHz}$, CW mode, with $P_{LO} = -3\text{dBm}$.
 - 6) Set the Spectrum Analyzer to the following:
 - a) Center Frequency = 4.9MHz.
 - b) Frequency Span = 1MHz.
 - c) Amplitude Reference Level = 0dBm.
 - d) Res. BW = 10kHz,
 - e) Vid. BW = 30kHz.Two CW tones will be on the screen of the spectrum analyzer, at 4.9MHz and 5.0MHz.
 - 7) Slowly adjust the power supply #4 for V_{ctrl} (V_{ctrl} or Gain Control Voltage) to set the output of Fundamental tones at -10dBm each.
- NOTE: Do not adjust this voltage to more than V_{cc1} . If necessary, adjust the P_{IF} of either Signal Generator #1 or Signal Generator #2 so that the two tones are equivalent in level or Power value (power delta of 0.3dB or less, preferably).
- 8) Record the actual value of the two tones on the Spectrum Analyzer. These are the two Fundamental tones.
 - 9) Set the Spectrum Analyzer to the following:
 - a) Center Frequency = 4.8MHz.
 - b) Frequency Span = 50kHz.
 - c) Amplitude Reference Level = -30dBm .
 - d) Averaging = ON.
 - e) Measure the lower IM3 Product on the Spectrum Analyzer at 4.8MHz.
 - 10) Repeat step 9 for the Upper IM3 product at 5.1MHz.
- NOTE: IM5 and IM7 products can be measured with higher IF input signal levels.

BASEBAND LOWPASS FILTER, IF DETECT (OVERLOAD) AND PHASE & AMPLITUDE MISMATCH MEASUREMENTS

- 1) Use setting steps 1 to 4 from previous DC power consumption measurements.
- 2) Set signal generator # 3 for $f_{LO}=570\text{MHz}$, CW mode, with $P_{LO} = -3\text{dBm}$.
- 3) Set Signal Generator # 1 for $f_{IF}=286.0\text{MHz}$, CW mode, with $P_{IF} = -30\text{dBm}$.
- 4) Turn “Off” the RF output for the signal generator #2.
- 5) Set dipswitch of EN and STBY to “Off “ position (Logic High).
- 6) Set the Spectrum Analyzer to the following:
 - a) Start Frequency = 100kHz.
 - b) Stop Frequency = 50MHz.
 - c) Amplitude Reference Level = 0dBm.
 - d) Res. BW = 100kHz.
- 7) Slowly adjust the Power Supply #4 for V_{cc4} (V_{ctrl} or Gain Control Voltage) to set the output tone at -4dBm .
- 8) BaseBand Filters frequency response can be measured by sweeping input IF frequency from 286MHz to 335MHz. Correspondingly, BB output will have 1 to 50MHz sweep. In case of manual

frequency sweep of IF input, the Spectrum Analyzer should be in “Maximum Hold” mode. One marker should be placed at 1MHz point as a reference and another marker should be placed at the point where the frequency response of the BB filter has a 3.0dB drop. This represents the 3.0dB corner frequency of the BB filter.

9) IF Detector (Overload) measurement:

- a) Change Signal Generator # 1 Output power with 1 or 2dB step size, from -30 to +8dBm.
- b) IF Detector (Overload) Output voltage should be in a range of 0.3 to 1.2 Volts correspondingly.

10) BaseBand Phase and Amplitude mismatch measurements.

- a) Connect two (vertical) inputs of the oscilloscope to BB outputs.

NOTE: An Oscilloscope of 1GHz or faster is recommended. Calibration and identical connecting cables are required. Measurements should be done with internal or external 50-ohm termination resistors.

- b) Measure Phase and Amplitude error. Phase error should be ± 3.0 degrees maximum. Amplitude error should be within ± 0.5 dB.

NOTE: If available, an Impedance Analyzer like the HP 4192A is recommended for BB Phase and Amplitude mismatch measurements.

QUICK START GUIDE FOR DEMONSTRATION CIRCUIT 696

IF RECEIVER, WIDE BB

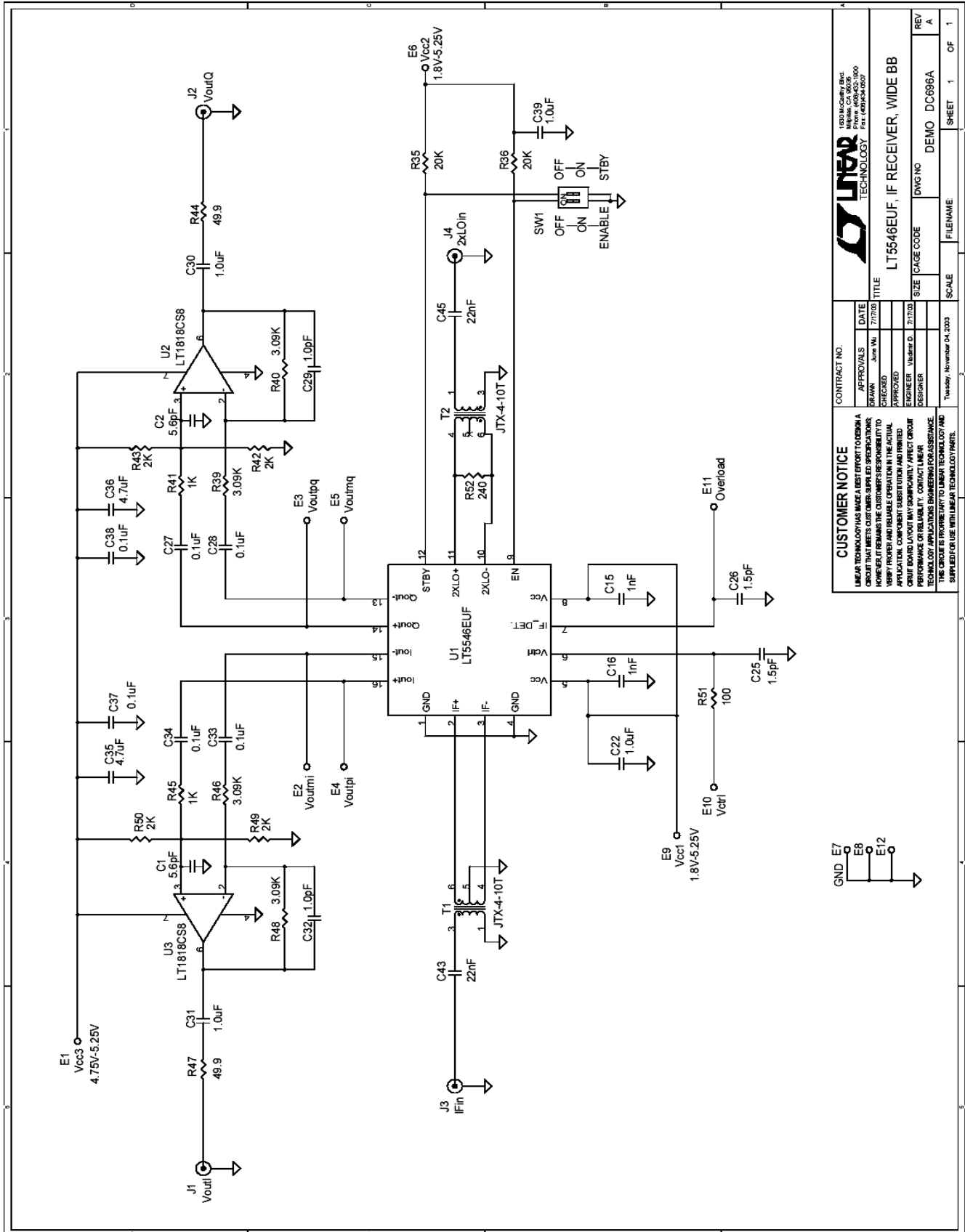

CUSTOMER NOTICE		CONTRACT NO.			
LINEAR TECHNOLOGY HAS MADE BEST EFFORT TO DESIGN A NUMBER OF DEMONSTRATION CIRCUITS. THE USER ASSUMES RESPONSIBILITY FOR VERIFYING PROPER AND RELIABLE OPERATION IN THE ACTUAL APPLICATION. COMPONENT SUBSTITUTION AND PRINTED CIRCUIT BOARD LAYOUT MAY SIGNIFICANTLY AFFECT CIRCUIT PERFORMANCE OR RELIABILITY. CONTACT LINEAR TECHNOLOGY APPLICATIONS ENGINEERING FOR ASSISTANCE.				1000 Mendenhall Blvd. Milpitas, CA 95028 Tel: (408) 297-2000 Fax: (408) 297-2001	
THIS CIRCUIT IS PROPRIETARY TO LINEAR TECHNOLOGY AND SUPPLIED FOR USE WITH LINEAR TECHNOLOGY PARTS.				TITLE: LT5546EUF, IF RECEIVER, WIDE BB	
DRAWN: June 01, 2003				DATE: 7/17/03	
CHECKED: [Signature]				APPROVED: [Signature]	
DESIGNER: [Signature]				ENGINEER: [Signature]	
FILE NAME: DEMO DC696A				SCALE: 1 OF 1	
SHEET: 1				REV: A	

X-ON Electronics

Largest Supplier of Electrical and Electronic Components

Click to view similar products for [RF Development Tools](#) category:

Click to view products by [Analog Devices](#) manufacturer:

Other Similar products are found below :

[MAAM-011117](#) [MAAP-015036-DIEEV2](#) [EV1HMC1113LP5](#) [EV1HMC6146BLC5A](#) [EV1HMC637ALP5](#) [EVAL-ADG919EBZ](#) [ADL5363-EVALZ](#) [LMV228SDEVAL](#) [SKYA21001-EVB](#) [SMP1331-085-EVB](#) [EV1HMC618ALP3](#) [EVAL01-HMC1041LC4](#) [MAAL-011111-000SMB](#) [MAAM-009633-001SMB](#) [MASW-000936-001SMB](#) [107712-HMC369LP3](#) [107780-HMC322ALP4](#) [SP000416870](#) [EV1HMC470ALP3](#) [EV1HMC520ALC4](#) [EV1HMC244AG16](#) [MAX2614EVKIT#](#) [124694-HMC742ALP5](#) [SC20ASATEA-8GB-STD](#) [MAX2837EVKIT+](#) [MAX2612EVKIT#](#) [MAX2692EVKIT#](#) [EV1HMC629ALP4E](#) [SKY12343-364LF-EVB](#) [108703-HMC452QS16G](#) [EV1HMC863ALC4](#) [119197-HMC658LP2](#) [EV1HMC647ALP6](#) [ADL5725-EVALZ](#) [106815-HMC441LM1](#) [EV1HMC1018ALP4](#) [UXN14M9PE](#) [MAX2016EVKIT](#) [EV1HMC939ALP4](#) [MAX2410EVKIT](#) [MAX2204EVKIT+](#) [EV1HMC8073LP3D](#) [SIMSA868-DKL](#) [SIMSA868C-DKL](#) [SKY65806-636EK1](#) [SKY68020-11EK1](#) [SKY67159-396EK1](#) [SKY66181-11-EK1](#) [SKY65804-696EK1](#) [SKY13396-397LF-EVB](#)