

# QUICK START GUIDE FOR DEMONSTRATION CIRCUIT 701 DUAL SYNCHRONOUS, 600mA, 1.5MHz STEP-DOWN DC/DC REGULATOR

LTC3407

## DESCRIPTION

Demonstration circuit 701 is a Dual Synchronous, 600mA, 1.5MHz Step-Down DC/DC Regulator featuring the LTC®3407. The DC701 has an input voltage range of 2.5V to 5.5V, and either output is capable of delivering up to 600mA of output current. In Burst Mode™ operation, the LTC3407 requires only 40 uA of quiescent current, and the DC701 provides higher efficiency at light load currents. In Pulse Skip mode, the DC701 provides lower output ripple voltage at light load currents. In either mode, the DC701 can provide up to 96% efficiency on either channel and consumes less than 1uA in shutdown. The LTC3407

comes in a small 10-Pin DFN package, which has an exposed pad on the bottom-side of the IC for better thermal performance. These features, plus the nominal operating frequency of 1.5MHz (allowing the exclusive use of low profile surface mount components), make the DC701 demo board an ideal circuit for use in battery-powered, hand-held applications.

**Design files for this circuit board are available. Call the LTC factory.**

LTC is a trademark of Linear Technology Corporation

Table 1. Performance Summary ( $T_A = 25^\circ\text{C}$ )

PARAMETER	CONDITION	VALUE
Minimum Input Voltage		2.5V
Maximum Input Voltage		5.5V
Output Voltage $V_{OUT1}$	$V_{IN} = 2.5\text{V to } 5.5\text{V}, I_{OUT1} = 0\text{A to } 600\text{ mA}$	1.2V $\pm 2\%$
		1.5V $\pm 2\%$
		1.8V $\pm 2\%$
Typical Output Ripple $V_{OUT1}$	$V_{IN} = 5\text{V}, I_{OUT1} = 600\text{ mA}$ (20 MHz BW)	20mV <sub>p-p</sub>
Output Regulation	Line	$\pm 1\%$
	Load	$\pm 1\%$
Output Voltage $V_{OUT2}$	$V_{IN} = 2.5\text{V to } 5.5\text{V}, I_{OUT2} = 0\text{A to } 600\text{ mA}$	2.5V $\pm 2\%$
Typical Output Ripple $V_{OUT2}$	$V_{IN} = 5\text{V}, I_{OUT2} = 600\text{ mA}$ (20 MHz BW)	20mV <sub>p-p</sub>
Output Regulation	Line	$\pm 1\%$
	Load	$\pm 1\%$
Nominal Switching Frequency		1.5 MHz

## QUICK START PROCEDURE

Demonstration circuit 701 is easy to set up to evaluate the performance of the LTC3407. Refer to Figure 1

for proper measurement equipment setup and follow the procedure below.

# QUICK START GUIDE FOR DEMONSTRATION CIRCUIT 701

## DUAL SYNCHRONOUS, 600mA, 1.5MHZ STEP-DOWN DC/DC REGULATOR

---

**Note:** When measuring the input or output voltage ripple, care must be taken to avoid a long ground lead on the oscilloscope probe. Measure the input or output voltage ripple by touching the probe tip directly across the Vin or Vout and GND terminals. See Figure 2 for proper scope probe technique.

**Note:** Capacitor C5 is an optional part. It was inserted on the DC701 to dampen the (possible) ringing voltage due to the use of long input leads. On a normal, typical PCB, with short traces, the capacitor is not needed.

1. Connect the input power supply to the Vin and GND terminals on the left-side of the board. Do not hot-plug Vin or increase Vin over the rated maximum supply voltage of 5.5V, or the part may be damaged. Connect the loads between the Vout and GND terminals on the right-side of the board. Refer to Figure 1 for the proper measurement equipment setup.
2. Before proceeding to operation, insert jumpers JP1 and JP2 into the OFF positions, jumper JP3 into the Vout1 voltage position of choice (1.2V, 1.5V, and 1.8V), and jumper JP4 into the desired mode of operation: Pulse Skip or Burst Mode.
3. Apply 3.3V at Vin. Measure both Vouts; they should read 0V. If desired, one can measure the shutdown supply current at this point. The supply current will be approximately 33 uA in shutdown,

with roughly 32 uA due to the optional 100 k $\Omega$  pull-up resistor of the Power-On Reset (POR) feature. This resistor can be removed, and the actual shutdown supply current (of approx. 1 uA) can be measured, if the POR feature is not required.

4. Turn on Vout1 and Vout2 by changing jumpers JP1 and JP2 from the OFF position(s) to the ON position(s). Vary the input voltage from 2.5V to 5.5V and adjust each load current from 0 to 600mA. Both output voltages should be regulating.
5. Set the load current of both outputs between 200 mA and 600 mA, and measure both output ripple voltages; they should measure less than 20 mVAC each. Also, observe the voltage waveform at the switch node (pin 3) of each regulator. The switching frequencies should be between 1.2 MHz and 1.8 MHz ( $T = 0.833 \mu\text{s}$  and  $0.555 \mu\text{s}$ ), and each switch node waveform should be rectangular in shape.
6. To change the mode of operation, change jumpers JP1 and JP2 from the ON position(s) to the OFF position(s). Then change jumper JP4 to the alternative position. Re-insert jumpers JP1 and JP2 into the ON position(s). Observe the voltage waveform at both switch nodes.

When finished, insert jumpers JP1 and JP2 to the OFF position(s) and disconnect the power.

If more efficiency is desired from the Demo Circuit, replace the stock inductor, a Taiyo Yuden part # LQLBC2518M2R2M, with a Murata inductor, # LQH32CN2R2M11. Due to its large size, the Murata inductor has lower DCR than the Taiyo Yuden inductor, thus has less power dissipation.

# QUICK START GUIDE FOR DEMONSTRATION CIRCUIT 701 DUAL SYNCHRONOUS, 600mA, 1.5MHZ STEP-DOWN DC/DC REGULATOR

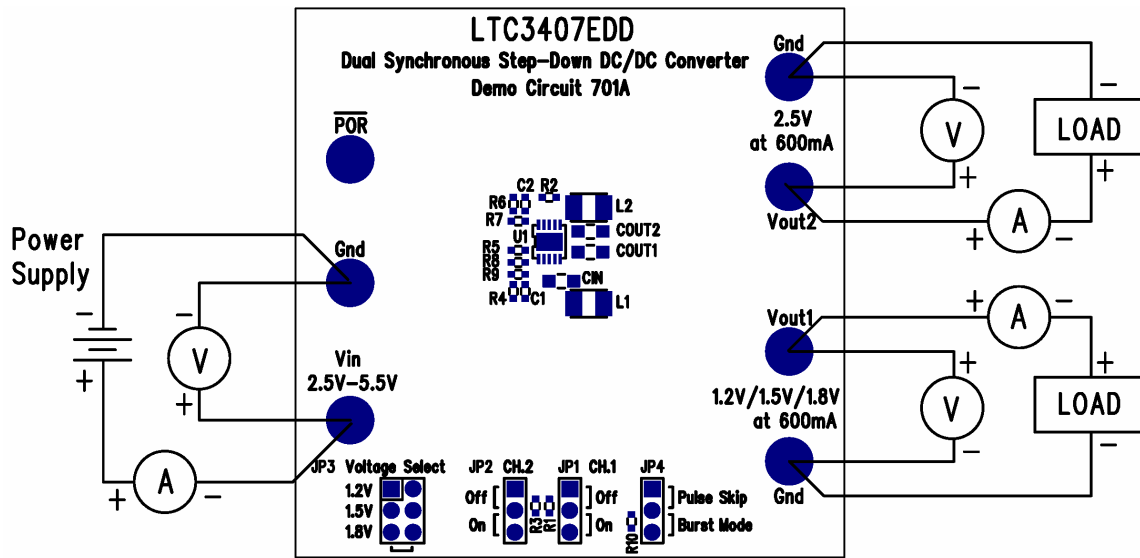

Figure 1. Proper Measurement Equipment Setup

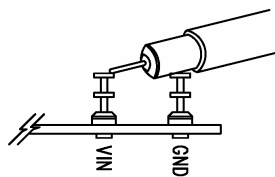
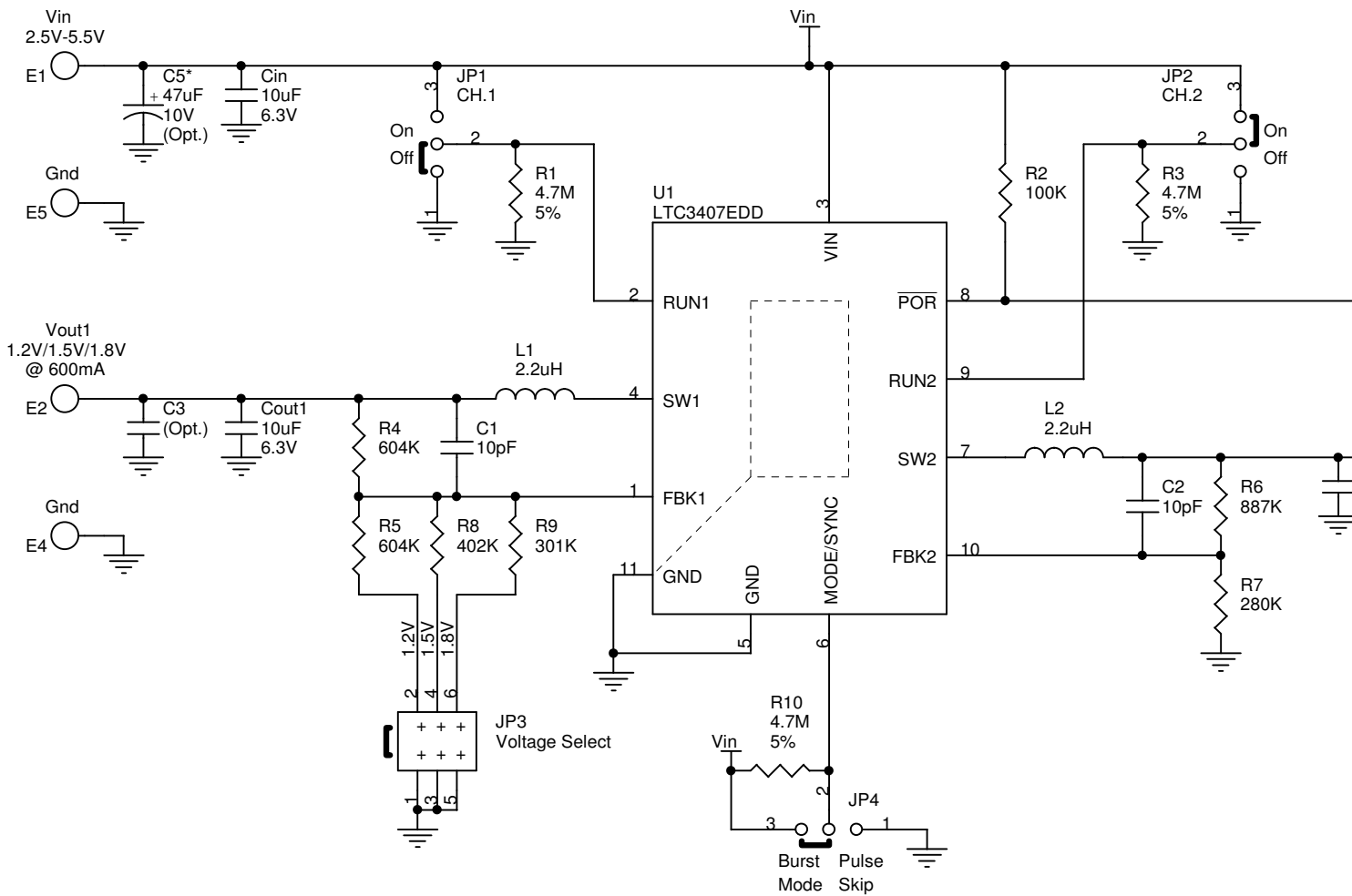

Figure 2. Scope Probe Placement for Measuring Input or Output Ripple

\* Capacitor C5 is an optional part. It was inserted on the DC701 to dampen the (possible) ringing voltage due to the use of long input leads. On a normal, typical PCB, with short traces, the capacitor is not needed.



LTC CONFIDENTIAL - FOR CUSTOMER USE ONLY

### Customer Notice

Linear Technology Has Made A Best Effort To Design A Circuit That Meets Customer-Supplied Specifications; However, It Remains The Customer's Responsibility To Verify Proper And Reliable Operation In The Actual Application. Component Substitution And Printed Circuit Board Layout May Significantly Affect Circuit Performance Or Reliability. Contact Linear Technology Applications Engineering For Assistance.  
This Circuit Is Proprietary To Linear Technology And Supplied For Use With Linear Technology Parts.

### LINEAR TECHNO

1630 McCARTHY BLVD.  
MILPITAS, CA. 95035  
408-432-1900  
408-434-0507 FAX

Title  
**Dual Synchronous St**

Size  
Document Number  
**Demo Circuit 70**

Date: Monday, November 10, 2003

<i>Item</i>	<i>Qty</i>	<i>Ref</i>	<i>Desc</i>	<i>Part Number</i>
1	3	COUT1,COUT2,CIN	CAP, X5R 10uF 6.3V 20% 0805	TAIYO YUDEN JMK212BJ106MG
2	2	C2,C1	CAP, NPO 10pF 50V 10% 0402	AVX 04025A100KAT
3	0	C3,C4 (Optional)	CAP, 0805	TBD
4	1	C5	CAP, TANT 47uF 10V 20% 6032	AVX TAJW476M010R
5	7	E1,E2,E3,E4,E5,E6,E7	TURRETS	MILL-MAX 2501-2
6	3	JP1,JP2,JP4	HEADER, 3PIN 2mm	COMM CON 2802S-03-G1
7	1	JP3	HEADER, 3X2 2mm	COMM CON 2202S-06G1
8	4	JP1,JP2,JP3,JP4	SHUNT,	COMM CON, CCIJ2MM-138G
9	2	L1,L2	INDUCTOR, 2.2uH	TAIYO YUDEN LQLBC25182R2M
10	3	R1,R3,R10	RES, 4.7M OHMS 5% 1/16W 0402	AAC CR05-475JM
11	1	R2	RES, 100K OHMS 1% 1/16W 0402	AAC CR05-1003FM
12	2	R4,R5	RES, 604K OHMS 1% 1/16W 0402	AAC CR05-6043FM
13	1	R6	RES, 887K OHMS 1% 1/16W 0402	AAC CR05-8873FM
14	1	R7	RES, 280K OHMS 1% 1/16W 0402	AAC CR05-2803FM
15	1	R8	RES, 402K OHMS 1% 1/16W 0402	AAC CR05-4023FM
16	1	R9	RES, 301K OHMS 1% 1/16W 0402	AAC CR05-3013FM
17	1	U1	IC, LTC3407EDD	LINEAR TECH. LTC3407EDD

## X-ON Electronics

Largest Supplier of Electrical and Electronic Components

*Click to view similar products for [Power Management IC Development Tools](#) category:*

*Click to view products by [Analog Devices](#) manufacturer:*

Other Similar products are found below :

[EVAL-ADM1168LQEBZ](#) [EVB-EP5348UI](#) [MIC23451-AAAYFL EV](#) [MIC5281YMME EV](#) [DA9063-EVAL](#) [ADP122-3.3-EVALZ](#) [ADP130-0.8-EVALZ](#) [ADP130-1.2-EVALZ](#) [ADP130-1.5-EVALZ](#) [ADP130-1.8-EVALZ](#) [ADP1714-3.3-EVALZ](#) [ADP1716-2.5-EVALZ](#) [ADP1740-1.5-EVALZ](#) [ADP1752-1.5-EVALZ](#) [ADP1828LC-EVALZ](#) [ADP1870-0.3-EVALZ](#) [ADP1871-0.6-EVALZ](#) [ADP1873-0.6-EVALZ](#) [ADP1874-0.3-EVALZ](#) [ADP1882-1.0-EVALZ](#) [ADP199CB-EVALZ](#) [ADP2102-1.25-EVALZ](#) [ADP2102-1.875EVALZ](#) [ADP2102-1.8-EVALZ](#) [ADP2102-2-EVALZ](#) [ADP2102-3-EVALZ](#) [ADP2102-4-EVALZ](#) [ADP2106-1.8-EVALZ](#) [ADP2147CB-110EVALZ](#) [AS3606-DB](#) [BQ24010EVM](#) [BQ24075TEVM](#) [BQ24155EVM](#) [BQ24157EVM-697](#) [BQ24160EVM-742](#) [BQ24296MEVM-655](#) [BQ25010EVM](#) [BQ3055EVM](#) [NCV891330PD50GEVB](#) [ISLUSBI2CKIT1Z](#) [LM2744EVAL](#) [LM2854EVAL](#) [LM3658SD-AEV/NOPB](#) [LM3658SDEV/NOPB](#) [LM3691TL-1.8EV/NOPB](#) [LM4510SDEV/NOPB](#) [LM5033SD-EVAL](#) [LP38512TS-1.8EV](#) [EVAL-ADM1186-1MBZ](#) [EVAL-ADM1186-2MBZ](#)