

QUICK START GUIDE FOR DEMONSTRATION CIRCUIT DC708

LITHIUM-ION LINEAR BATTERY CHARGER WITH THERMAL REGULATION

LTC4064EMS-4.0

DESCRIPTION

Demonstration circuit DC708 is a complete constant-current, constant-voltage battery charger designed to charge one Lithium-Ion cell used in battery backup applications or applications that require greatly increased cycle life at the expense of battery capacity. The LTC4064EMS-4.0 used on this demo circuit features an internal P-channel power MOSFET with a unique thermal feedback loop that reduces the output current under high ambient temperature and/or high power dissipation conditions. This feature allows the charger to provide higher charge currents under normal conditions and still provide safe charging under abnormal conditions such as high ambient temperature, high input voltage or low battery voltage. The IC is available in a 10-pin MSOP thermally enhanced package featuring an exposed bottom-side metal pad for soldering to the PC board.

Other Features include:

- Preset float voltage of $4.0V \pm 1\%$.
- Greatly increased cycle life when used for charging 4.1V or 4.2V batteries.
- 1A and 0.5A Constant Current selected by a jumper.
- Capable of charging directly from USB power.
- 3-hour charge termination timer. This timer can be set for other time periods through a capacitor change. For instance, you may want to use a much shorter period (on the order of 30 seconds) when evaluating the board with a battery simulator instead of a real Li-Ion battery.
- Charge Current Monitor Output can be used for gas gauging.
- Manual Shutdown
- Low battery drain current when input supply is removed

- No isolation diode or current sense resistor required.
- C/10 Trickle charge for deeply discharged batteries
- Auto recharge when battery voltage drops below pre-set threshold
- Input Power OK LED indicator (ACPR)
- C/10 Charge LED indicator (CHRG)
- Fault LED indicator for “out of temp range” (FAULT)

Small surface mount components are used to minimize board space and height with the circuitry occupying approximately 0.15 square inches of board space with a height of 0.054 inches (1.4mm).

Table 1. Typical Demo Board Specifications

Input Voltage Range V_{IN}	4.25V to 7V (upper range limited by PC board dissipation)
Output Voltage V_{BAT} (constant voltage mode)	4.0V $\pm 1\%$
Output Current I_{BAT} (constant current mode)	1 A $\pm 8\%$, 0.5A $\pm 8\%$ (selected by jumper)
Current Monitor Output	1.5V $\pm 5\%$ @ Full Current
Output Current I_{BAT} (trickle current mode)	100mA $\pm 20\%$, 50mA $\pm 20\%$
C/10 CHRG LED Threshold Level	100mA $\pm 25\%$. 50Ma $\pm 25\%$
Circuit Board Temperature in Thermal Feedback Mode	60°C to 70°C
Trickle Charge Threshold Voltage	2.457V
Battery Drain Current with V_{IN} Removed	<1 μ A

QUICK START GUIDE FOR DEMONSTRATION CIRCUIT DC708

LITHIUM-ION LINEAR BATTERY CHARGER WITH THERMAL REGULATION

QUICK START PROCEDURE

To save time, we recommend using a battery simulator (described in Table 2 and Figure 1•) If an actual rechargeable Li-Ion battery is used, keep the DC resistance between the charger and the battery to a minimum, as this will affect the charge current in the constant voltage mode.

Table 2. Test Equipment Required for Demo Board Evaluation

Lab Power supply for input power	0 to 7V, 1.2A
Digital voltmeter for measuring input voltage (VIN)	3 1/2 digits
Digital voltmeter for measuring battery voltage (VBAT)	4 1/2 digits, resolution to 1mV
Digital voltmeter for measuring PROG pin voltage (current monitor)	3 1/2 digits, resolution to 1mV
Digital voltmeter for measuring voltage across current sense resistor (IBAT)	100mV range
4.2V Rechargeable Li-Ion Cell or Battery Simulator	600mA/Hr to 1.3A/Hr

Battery Simulator Consists of:

Power supply with coarse and fine output voltage adjust controls	0 to 5V, 2.5A
Power resistor (preload for power supply)	2Ω, 10W
Current sense resistor for measuring charge current	0.1Ω, 1%, 1W
Current sense resistor for measuring battery drain current	1k, 1%, 0.5W

SETUP

Refer to Table 2 and Figure 1 for equipment requirements and proper setup.

1. Set jumper JP1 to the "RUN" position (lower position).
2. Set jumper JP2 to the lower position, which programs the constant charge current to 1A.
3. Set the input power supply to 0V, and then connect it to the VIN and GND pins of the demo board.

4. Set the battery simulator to 0V, and then connect it to the BAT and GND pins.
5. Connect the digital voltmeters as shown in the setup diagram to measure VIN, V(current monitor), charge voltage (VBAT) and the charge current (IBAT).

EVALUATION

Undervoltage Lockout Feature

- Increase the input power supply to approximately 3.8V (battery simulator power supply set for 0V).

The charger output voltage and charge current should be 0. All three LEDs should be off. The charger is in shutdown due to the undervoltage lockout feature.

Trickle Charge Current

- Increase the input voltage to 5V and keep the battery simulator power supply at 0V.

The CHRГ and ACPR LEDs should now be on, and the FAULT LED should be off. The charger output voltage (VBAT) should be approximately 240mV, and the charge current should be about 100mA (10mV on the charge current DVM). This is the trickle charge mode for a deeply discharged battery. Typically, a battery that has not been charged for a long time.

Constant Current Charge

- Starting at 0V, slowly increase the battery simulator power supply (VBAT), observing the charger's output voltage on the DVM.

When the charger's output voltage exceeds approximately 2.45V, the charger will suddenly enter the constant current portion of the charge cycle, resulting in an abrupt jump in the charge current to the programmed value of approximately 1.0A (100mV on the charge current DVM). This is constant current mode.

Move jumper JP2 to the upper position (0.5A) to reduce the charge current (IBAT) to 500mA, resulting in a reading of approximately 50mV on the charge cur-

QUICK START GUIDE FOR DEMONSTRATION CIRCUIT DC708

LITHIUM-ION LINEAR BATTERY CHARGER WITH THERMAL REGULATION

rent DVM. Move the jumper back to the original position.

VPROG Verification

- With 1.0A charge current flowing into the battery simulator, measure the current monitor pin voltage VPROG. This voltage is proportional to charge current with 1.5V indicating full programmed current (1.0A).

Constant Voltage Charge

1. Continue slowly increasing the battery simulator power supply, thus simulating a battery accepting charge.

The charge current should remain at the programmed value of 1.0A until the charger output voltage is within approximately 10mV of the of the preset charge voltage (4.0V), at which time the charge current will begin to decrease. This is the beginning of the constant voltage portion of the charge cycle.

2. Continue slowly increasing the battery simulator power supply until the charge current drops to approximately 200mA (20mV on the charge current DVM), then read the charger output voltage. This reading is the charger float voltage which should be $4.0V \pm 40mV$.

Shutdown

1. Move the SHDN/CHRG jumper JP1 to the upper position.

This shuts the charger down dropping the charge current to 0mA. This is the shutdown mode.

2. Move the jumper back to the original location.

Charge LED, C/10 Charge Near Complete

- Continue to slowly increase the battery simulator power supply while observing the CHRG LED. The LED will go out when the charge current drops to approximately 10% of the programmed charge current of 1.0A. This verifies that the C/10 output is operating correctly.

NOTE: The LED current drops from approximately 10mA when the LED is on, to approximately $25\mu A$ when the charge current drops to 10%, and drops to

$0\mu A$ after the timer has timed out. (3 hours when a $0.1\mu F$ timing capacitor is used).

At C/10, when the CHRG LED goes out, a 4.2V battery is about 60% charged. The charger will continue charging for 3 hours ($0.1\mu F$ timing capacitor) then stop, at which point the battery is approximately 68% charged.

NOTE: Charging a 4.2V Li-Ion battery at 4.0V will decrease the mah capacity of the battery to approximately 68%, but will extend the battery cycle life to many thousands of cycles, possibly 10,000 or more cycles.

Recharge

- After the timer has timed out, slowly decrease the battery simulator power supply. At around 3.9V, the 1.0A charge current should return. This is the Recharge Threshold Voltage.

NOTE: For evaluation purposes, the time can be decreased from the programmed 3 hours to approximately 30 seconds by reducing the timer capacitor (C3) from $0.1\mu F$ to 270pF.

Sleep Mode

- To verify battery drain current in the sleep mode, remove the input supply voltage or shut the supply off, replace the 0.1Ω current sense resistor with a $1k\Omega$, and set the battery simulator power supply to approximately 3.9V. The charge current DVM will now read battery drain current with $1mV/\mu A$.

NOTE: On this demo board, the thermistor (R6) is replaced with a $10k\Omega$ resistor. Because the board can get quite hot, the thermistor must be located near the battery, not on the pc board.

QUICK START GUIDE FOR DEMONSTRATION CIRCUIT DC708 LITHIUM-ION LINEAR BATTERY CHARGER WITH THERMAL REGULATION

Thermal Control Loop

1. Increase the input voltage to about 6.5V, and reduce the battery simulator power supply to around 3V.

This causes increased power dissipation, which raises the LTC4064 junction temperature. When the junction temperature reaches approximately 105°C, the charge

current decreases enough to maintain the junction temperature at 105°C.

2. Increase the battery simulator voltage or reduce the input voltage to reduce the charger power dissipation and allow the charge current to return to the programmed current of 1A.

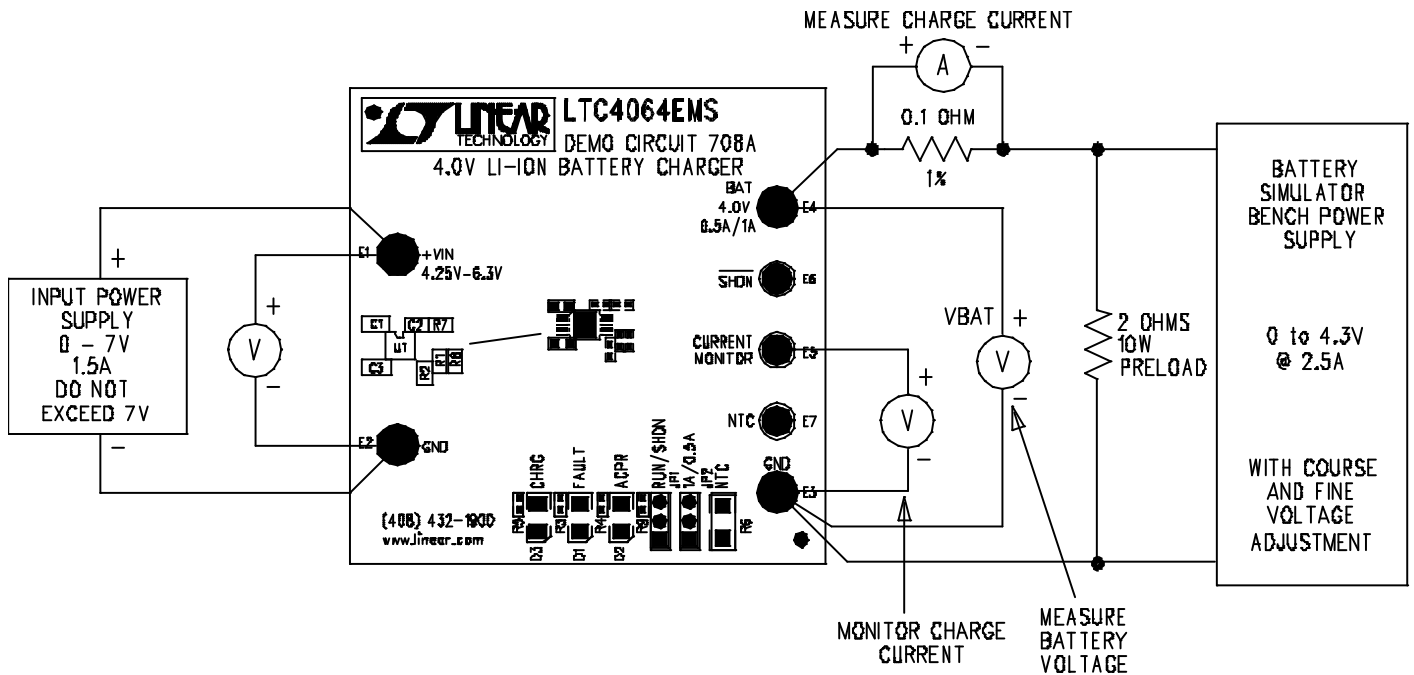
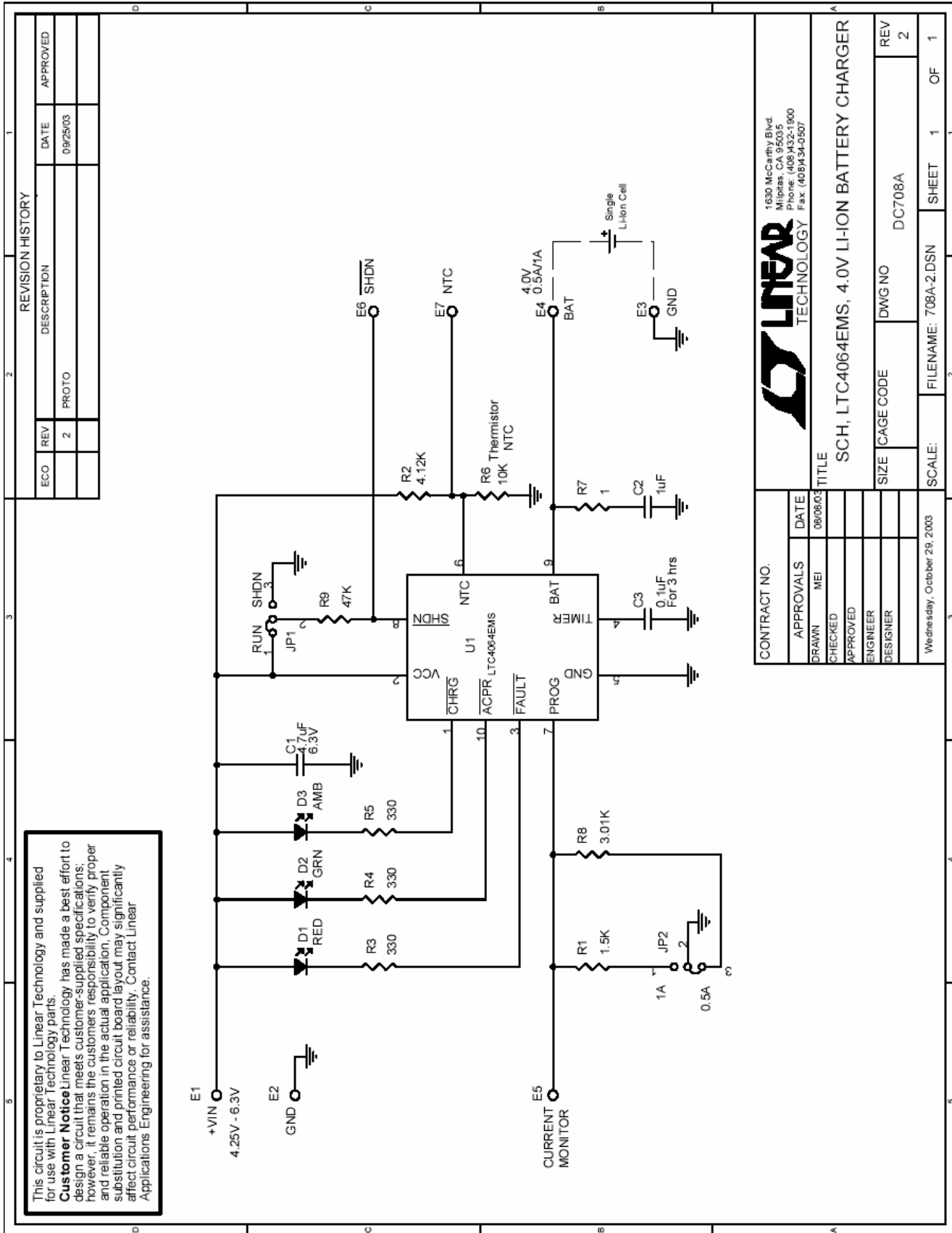

Figure 1. Proper Measurement Equipment Setup

QUICK START GUIDE FOR DEMONSTRATION CIRCUIT DC708

LITHIUM-ION LINEAR BATTERY CHARGER WITH THERMAL REGULATION



CONTRACT NO.

APPROVALS	DATE
DRAWN: MEI	08/08/03
CHECKED:	
APPROVED:	
ENGINEER:	
DESIGNER:	

Wednesday, October 29, 2003

LINEAR TECHNOLOGY

1630 McCarthy Blvd.
Milpitas, CA 95035
Phone: (408) 432-1900
Fax: (408) 34-0507

TITLE
SCH, LTC4064EMS, 4.0V LI-ION BATTERY CHARGER

SIZE: CAGE CODE: DC708A DWG NO: REV: 2

SCALE: FILENAME: 708A-2.DSN SHEET: 1 OF 1

X-ON Electronics

Largest Supplier of Electrical and Electronic Components

Click to view similar products for [Power Management IC Development Tools](#) category:

Click to view products by [Analog Devices](#) manufacturer:

Other Similar products are found below :

[EVAL-ADM1168LQEBZ](#) [EVB-EP5348UI](#) [MIC23451-AAAYFL EV](#) [MIC5281YMME EV](#) [DA9063-EVAL](#) [ADP122-3.3-EVALZ](#) [ADP130-0.8-EVALZ](#) [ADP130-1.2-EVALZ](#) [ADP130-1.5-EVALZ](#) [ADP130-1.8-EVALZ](#) [ADP1714-3.3-EVALZ](#) [ADP1716-2.5-EVALZ](#) [ADP1740-1.5-EVALZ](#) [ADP1752-1.5-EVALZ](#) [ADP1828LC-EVALZ](#) [ADP1870-0.3-EVALZ](#) [ADP1871-0.6-EVALZ](#) [ADP1873-0.6-EVALZ](#) [ADP1874-0.3-EVALZ](#) [ADP1882-1.0-EVALZ](#) [ADP199CB-EVALZ](#) [ADP2102-1.25-EVALZ](#) [ADP2102-1.875EVALZ](#) [ADP2102-1.8-EVALZ](#) [ADP2102-2-EVALZ](#) [ADP2102-3-EVALZ](#) [ADP2102-4-EVALZ](#) [ADP2106-1.8-EVALZ](#) [ADP2147CB-110EVALZ](#) [AS3606-DB](#) [BQ24010EVM](#) [BQ24075TEVM](#) [BQ24155EVM](#) [BQ24157EVM-697](#) [BQ24160EVM-742](#) [BQ24296MEVM-655](#) [BQ25010EVM](#) [BQ3055EVM](#) [NCV891330PD50GEVB](#) [ISLUSBI2CKIT1Z](#) [LM2744EVAL](#) [LM2854EVAL](#) [LM3658SD-AEV/NOPB](#) [LM3658SDEV/NOPB](#) [LM3691TL-1.8EV/NOPB](#) [LM4510SDEV/NOPB](#) [LM5033SD-EVAL](#) [LP38512TS-1.8EV](#) [EVAL-ADM1186-1MBZ](#) [EVAL-ADM1186-2MBZ](#)