

DESCRIPTION

Demonstration circuit 748A is a wide range RF power detector featuring the LT[®]5534.

The LT5534 is a 50MHz to 3GHz monolithic RF power detector capable of measuring RF signals over a 60dB dynamic range. The RF signal in a decibel scale is precisely converted into DC voltage on a linear scale. The 60dB input dynamic range is achieved using cascaded RF detectors and RF limiters. Their outputs are

summed to generate an accurate log-linear DC voltage proportional to the input RF signal in dB. The output is buffered with a low output impedance driver. The LT5534 features superior temperature stability and fast transient response (typical full-scale setting time is 38ns).

Design files for this circuit board are available. Call the LTC factory.

Table 1. Typical Performance Summary ($V_{CC} = 3V$, $EN = 3V$, $T_A = 25^\circ C$, source impedance = 50Ω , unless otherwise noted. Test circuit shown in Figure 1.)

PARAMETER	CONDITION	VALUE
Supply Voltage		2.7V to 5.25V
Supply Current		7mA
Input Impedance		2k Ω
Output Impedance		32 Ω
Output DC voltage	No RF Input Signal	142mV
$f_{RF} = 50MHz$		
RF Input Power Range		-58dBm to +2dBm
Dynamic Range	$\pm 3dB$ Linearity Error, $T_A = -40^\circ C$ to $85^\circ C$	60dB
Output Slope		44mV/dB
Output Variation vs. Temperature	$P_{in} = -48dBm$ to $-14dBm$, $T_A = -40^\circ C$ to $85^\circ C$	0.007dB/ $^\circ C$
$f_{RF} = 900MHz$		
RF Input Power Range		-60dBm to 0dBm
Dynamic Range	$\pm 3dB$ Linearity Error, $T_A = -40^\circ C$ to $85^\circ C$	60dB
Output Slope		41mV/dB
Output Variation vs. Temperature	$P_{in} = -48dBm$ to $-14dBm$, $T_A = -40^\circ C$ to $85^\circ C$	0.008dB/ $^\circ C$
$f_{RF} = 1900MHz$		
RF Input Power Range		-63dBm to -2dBm
Dynamic Range	$\pm 3dB$ Linearity Error, $T_A = -40^\circ C$ to $85^\circ C$	61dB
Output Slope		36.6mV/dB
Output Variation vs. Temperature	$P_{in} = -48dBm$ to $-14dBm$, $T_A = -40^\circ C$ to $85^\circ C$	0.012dB/ $^\circ C$
Output intercept	50 Ω External Termination, $T_A = -40^\circ C$ to $85^\circ C$	-64dBm
$f_{RF} = 2500MHz$		
RF Input Power Range		-63dBm to -3dBm
Dynamic Range	$\pm 3dB$ Linearity Error, $T_A = -40^\circ C$ to $85^\circ C$	60dB
Output Slope		35mV/dB
Output Variation vs. Temperature	$P_{in} = -48dBm$ to $-14dBm$, $T_A = -40^\circ C$ to $85^\circ C$	0.025dB/ $^\circ C$

QUICK START GUIDE FOR DEMONSTRATION CIRCUIT 748A

50MHZ TO 3GHZ RF POWER DETECTOR WITH 60dB DYNAMIC RANGE

QUICK START PROCEDURE

Demonstration circuit 748A is easy to set up to evaluate the performance of the LT5534. Refer to Figure 1 for proper measurement equipment setup and follow the procedure below:

NOTE: Demonstration circuit 748A is optimized for evaluations over the frequency range from 50MHz to 2.5GHz. Its RF input port is well matched with better than 10dB return loss up to 2.5GHz. At higher frequencies, return loss can be improved with proper matching.

1. Connect DC power supply negative (-) output to demo board Gnd pin (E3 or E5).
2. Connect DC power supply positive (+) output (2.7V to 5.25V) to demo board Vcc pin (E1).

NOTE: Do not exceed 5.5V, the absolute maximum supply voltage.

3. Connect voltmeter negative (-) lead to demo board Gnd pin (E3 or E5).
4. Connect voltmeter positive (+) lead to the demo board Vout pin (E2).

5. Connect RF signal generator output to demo board RF in port (SMA connector J1) via coaxial cable.
6. Using a jumper cable, connect demo board Vcc pin (E1) to EN pin (E4). Now the detector is enabled (on) and is ready for measurement.

NOTE: Make sure that the power is not applied to the EN pin before it is applied to the Vcc pin. The voltage on the EN pin must never exceed the voltage on the Vcc pin.

7. Apply an RF input signal and measure Vout DC voltage.

NOTE: Do not exceed +10dBm, the absolute maximum RF input power.

8. The dynamic range is defined as the range over which the linearity error is within ± 3 dB. The linearity error is calculated by the difference between the incremental slope of the output and the average output slope from -48dBm to -14dBm.

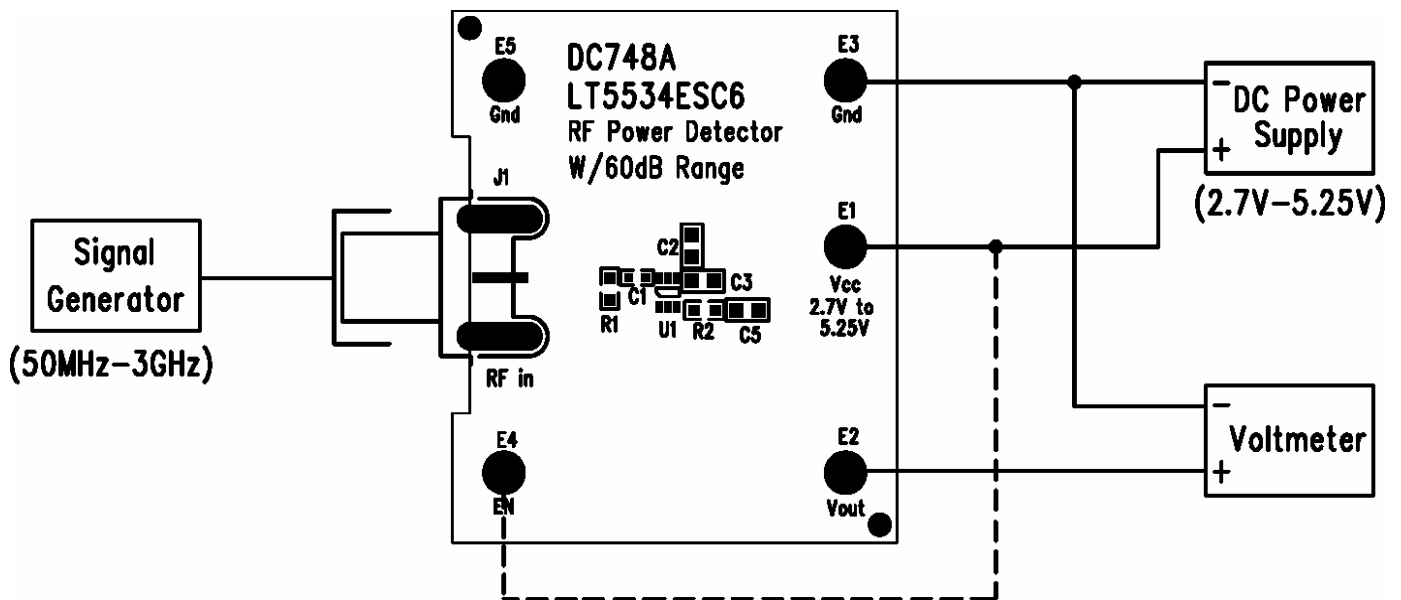
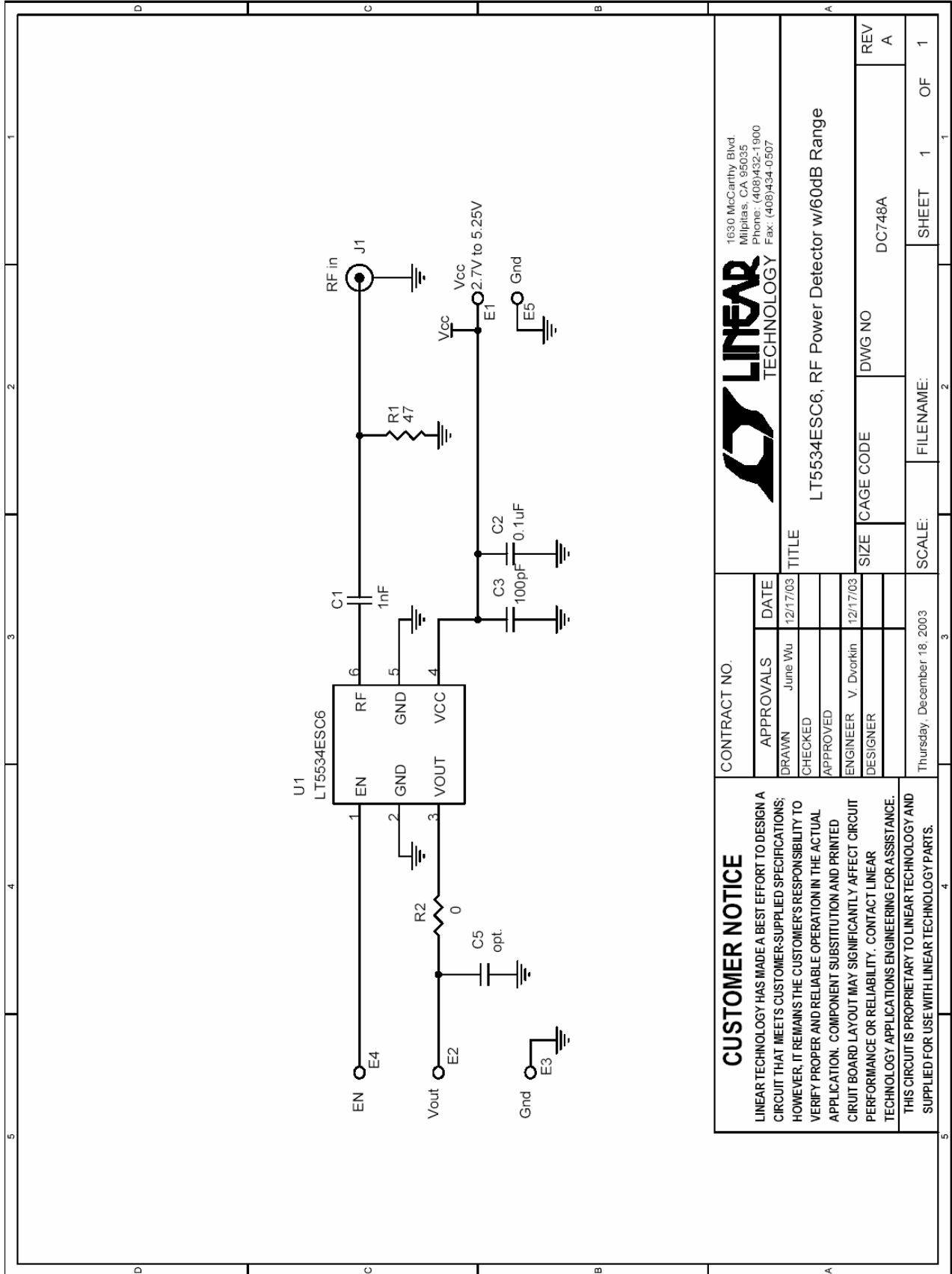

Figure 1. Proper Measurement Equipment Setup

QUICK START GUIDE FOR DEMONSTRATION CIRCUIT 748A

50MHZ TO 3GHZ RF POWER DETECTOR WITH 60dB DYNAMIC RANGE



CONTRACT NO.		LINEAR TECHNOLOGY		1630 McCarthy Blvd. Milpitas, CA 95035 Phone: (408)432-1900 Fax: (408)434-0507	
APPROVALS	DATE	TITLE			
DRAWN June Wu	12/17/03	LT5534ESC6, RF Power Detector w/60dB Range			
CHECKED		SIZE	CAGE CODE	DWG NO	REV
APPROVED				DC748A	A
ENGINEER V. Dvorkin	12/17/03				
DESIGNER					
Thursday, December 18, 2003		SCALE:		FILENAME:	SHEET 1 OF 1

CUSTOMER NOTICE
 LINEAR TECHNOLOGY HAS MADE A BEST EFFORT TO DESIGN A CIRCUIT THAT MEETS CUSTOMER-SUPPLIED SPECIFICATIONS; HOWEVER, IT REMAINS THE CUSTOMER'S RESPONSIBILITY TO VERIFY PROPER AND RELIABLE OPERATION IN THE ACTUAL APPLICATION. COMPONENT SUBSTITUTION AND PRINTED CIRCUIT BOARD LAYOUT MAY SIGNIFICANTLY AFFECT CIRCUIT PERFORMANCE OR RELIABILITY. CONTACT LINEAR TECHNOLOGY APPLICATIONS ENGINEERING FOR ASSISTANCE.
 THIS CIRCUIT IS PROPRIETARY TO LINEAR TECHNOLOGY AND SUPPLIED FOR USE WITH LINEAR TECHNOLOGY PARTS.

X-ON Electronics

Largest Supplier of Electrical and Electronic Components

Click to view similar products for [RF Development Tools](#) category:

Click to view products by [Analog Devices](#) manufacturer:

Other Similar products are found below :

[MAAM-011117](#) [MAAP-015036-DIEEV2](#) [EV1HMC1113LP5](#) [EV1HMC6146BLC5A](#) [EV1HMC637ALP5](#) [EVAL-ADG919EBZ](#) [ADL5363-EVALZ](#) [LMV228SDEVAL](#) [SKYA21001-EVB](#) [SMP1331-085-EVB](#) [EV1HMC618ALP3](#) [EVAL01-HMC1041LC4](#) [MAAL-011111-000SMB](#) [MAAM-009633-001SMB](#) [MASW-000936-001SMB](#) [107712-HMC369LP3](#) [107780-HMC322ALP4](#) [SP000416870](#) [EV1HMC470ALP3](#) [EV1HMC520ALC4](#) [EV1HMC244AG16](#) [MAX2614EVKIT#](#) [124694-HMC742ALP5](#) [SC20ASATEA-8GB-STD](#) [MAX2837EVKIT+](#) [MAX2612EVKIT#](#) [MAX2692EVKIT#](#) [EV1HMC629ALP4E](#) [SKY12343-364LF-EVB](#) [108703-HMC452QS16G](#) [EV1HMC863ALC4](#) [119197-HMC658LP2](#) [EV1HMC647ALP6](#) [ADL5725-EVALZ](#) [106815-HMC441LM1](#) [EV1HMC1018ALP4](#) [UXN14M9PE](#) [MAX2016EVKIT](#) [EV1HMC939ALP4](#) [MAX2410EVKIT](#) [MAX2204EVKIT+](#) [EV1HMC8073LP3D](#) [SIMSA868-DKL](#) [SIMSA868C-DKL](#) [SKY65806-636EK1](#) [SKY68020-11EK1](#) [SKY67159-396EK1](#) [SKY66181-11-EK1](#) [SKY65804-696EK1](#) [SKY13396-397LF-EVB](#)