

DESCRIPTION

Demonstration circuit 753 is a high linearity, low power downconverting mixer featuring the LT5526. The RF input frequency is 900MHz, and the IF output frequency is 140MHz.

The LT5526 is a low power broadband mixer optimized for high linearity applications such as point-to-point data transmission, cable infrastructure, and wireless infrastructure systems. The device includes an internally matched high speed LO amplifier driving a double-balanced active mixer core. An integrated RF buffer amplifier provides excellent LO-RF isolation. The RF and IF ports can be easily matched across a

broad range of frequencies for use in a wide variety of applications.

The LT5526 offers a high performance alternative to passive mixers. Unlike passive mixers which have conversion loss and require high LO drive levels, the LT5526 delivers conversion gain at significantly lower LO input levels and is much less sensitive to LO power level variations.

Design files for this circuit board are available. Call the LTC factory.

LT is a trademark of Linear Technology Corporation

Table 1. Typical Performance Summary ($V_{CC} = 5V$, EN = High, $f_{RF} = 900MHz$, $P_{RF} = -15dBm$, $f_{LO} = 760MHz$, $P_{LO} = -5dBm$, $f_{IF} = 140MHz$, $T_A = 25^\circ C$, unless otherwise noted. Test circuit shown in Figure 2.)

PARAMETER	CONDITION	VALUE
Supply Voltage		3.6V to 5.25V
Supply Current	EN = High	28mA
Maximum Shutdown Current	EN = Low	100 μ A
RF to LO isolation		55dB
Conversion Gain		0.6dB
Input 3 rd Order Intercept	2-Tone, -15dBm/tone, $\Delta f = 1MHz$	16.5dBm
Single Sideband Noise Figure		11.0dB
LO to RF Leakage		-65dBm
LO to IF Leakage		-74dBm
2RF-2LO Output Spurious Product ($f_{RF} = f_{LO} \pm f_{IF}/2$)	$f_{RF} = 830MHz$, $P_{RF} = -15dBm$, $f_{LO} = 760MHz$	-72dBc
3RF-3LO Output Spurious Product ($f_{RF} = f_{LO} \pm f_{IF}/3$)	$f_{RF} = 806.67MHz$, $P_{RF} = -15dBm$, $f_{LO} = 760MHz$	-68dBc
Input 1dB Compression		5dBm

APPLICATION NOTE

ABSOLUTE MAXIMUM INPUT RATING

Supply Voltage	5.5V
Enable Voltage	-0.3V to $V_{CC}+0.3V$
RF Input Power	+10dBm
LO Input Power	+10dBm

FREQUENCY RANGE

Demonstration circuit 753 is optimized for evaluating the LT5526 for 900MHz RF to 140MHz IF downconversion with either low-side or high-side LO injection.

The RF input port is well matched with better than 10dB return loss over the frequency range from 750MHz to 1350MHz. The IF output port is matched for 140MHz with a 10dB return loss bandwidth of 200MHz.

With proper matching, the RF and IF ports can be tuned for operation at other frequencies. Please refer to the LT5526 datasheet Applications Information section.

The LO input is internally matched to 50Ω. External 100pF DC blocking capacitors, C5 and C6, provide a broadband match from about 100MHz to 2.7GHz. The LO input match can be improved at lower frequencies by increasing the values of C5 and C6.

QUICK START PROCEDURE

Demonstration circuit 753 is easy to set up to evaluate the performance of the LT5526. Refer to Figure 1 for proper measurement equipment setup and follow the procedure below:

1. Connect signal generator outputs to demo board RFin port (SMA connector J1) and LOin port (SMA connector J3) via coaxial cable.
2. Connect demo board IFout port (SMA connector J2) to spectrum analyzer input via coaxial cable.

TEST EQUIPMENT AND SETUP

Refer to Figure 1 for proper measurement equipment setup.

Use high performance signal generators with low harmonic output for 2-tone measurements. Otherwise, low-pass filters at the signal generator outputs should be used to suppress higher-order harmonics.

High quality combiners that provide broadband 50Ω termination on all ports and have good port-to-port isolation should be used. Attenuators on the outputs of the signal generators are recommended to further improve source isolation to prevent the sources from modulating each other and generating intermodulation products.

Spectrum analyzers can produce significant internal distortion products if they are overdriven. Generally, spectrum analyzers are designed to operate at their best with about -30dBm to -40dBm at their input. Sufficient spectrum analyzer input attenuation should be used to avoid saturating the instrument.

Before performing measurements on the DUT, the system performance should be evaluated to ensure that: 1) a clean input signal is obtained and 2) the spectrum analyzer internal distortion is minimized.

3. Connect DC power supply negative (-) output to demo board GND pin (E2 or E4).
4. Connect DC power supply positive (+) output (3.6V to 5.25V) to demo board Vcc pin (E1).

NOTE: Do not exceed 5.5V, the absolute maximum supply voltage.

QUICK START GUIDE FOR DEMONSTRATION CIRCUIT 753

900MHZ HIGH LINEARITY, LOW POWER DOWNCONVERTING MIXER

- Using a jumper cable, connect demo board Vcc pin (E3) to EN pin (E1). Now the detector is enabled (on) and is ready for measurement.

NOTE: Make sure that the power is not applied to the EN pin before it is applied to the Vcc pin. The voltage on the EN pin must never exceed the voltage on the Vcc pin +0.3V.

- Apply RF and LO input signals to perform AC measurements.

NOTE: Do not exceed +10dBm, the absolute maximum RF and LO input power.

- Set the LO signal generator (#1) to provide a 760MHz, -5dBm, CW signal to the demo board LO input port.
- Set the RF signal generators (#2 and #3) to provide two -15dBm CW signals to the demo board RF input port—one at 900MHz, and the other at 901MHz.
- Set the Spectrum Analyzer's frequency range to capture the 140MHz IF output. Sufficient spectrum analyzer input attenuation should be used to avoid saturating the instrument.
- Conversion gain and Input 3rd order intercept can be measured:
 - $G_c = P_1 - P_{in}$
 - $IIP3 = (P_1 - P_3) / 2 + P_{in}$

Where P1 is the power level of the fundamental output tone at 140MHz or at 141MHz, P3 is the 3rd

order product at 139MHz or at 142MHz, and Pin is the input power (in this case, -15dBm). All units are in dBm.

- To measure the 2RF-2LO output spurious product, turn off signal generator 3. Set signal generator 2 to $f_{RF} = f_{LO} \pm f_{IF}/2$. In this case, $f_{RF} = 760\text{MHz} + 140\text{MHz} / 2 = 830\text{MHz}$. Then the desired output would be at 70MHz, and the 2RF-2LO output spur would be at 140MHz. The dBc difference between the two tones is the 2RF-2LO output spurious product.
- Follow the same procedure for 3RF-3LO output spurious product measurement. This time, set signal generator 2 to $f_{RF} = f_{LO} \pm f_{IF}/3 = 760\text{MHz} + 140\text{MHz} / 3 = 806.67\text{MHz}$. The desired output would be at 46.67MHz, and the 3RF-3LO output spur would be at 140MHz. The dBc difference between the two tones is the 3RF-3LO output spurious product.
- Measure RF to LO isolation, LO leakages, and Input 1dB compression.
- Single-Sideband Noise Figure can be measured on a noise figure meter. Refer to noise figure meter manual for instructions. Be sure to use a high quality signal generator and a band-pass filter on the LO input. A band-pass filter on the RF input port is required for image suppression.

QUICK START GUIDE FOR DEMONSTRATION CIRCUIT 753

900MHZ HIGH LINEARITY, LOW POWER DOWNCONVERTING MIXER

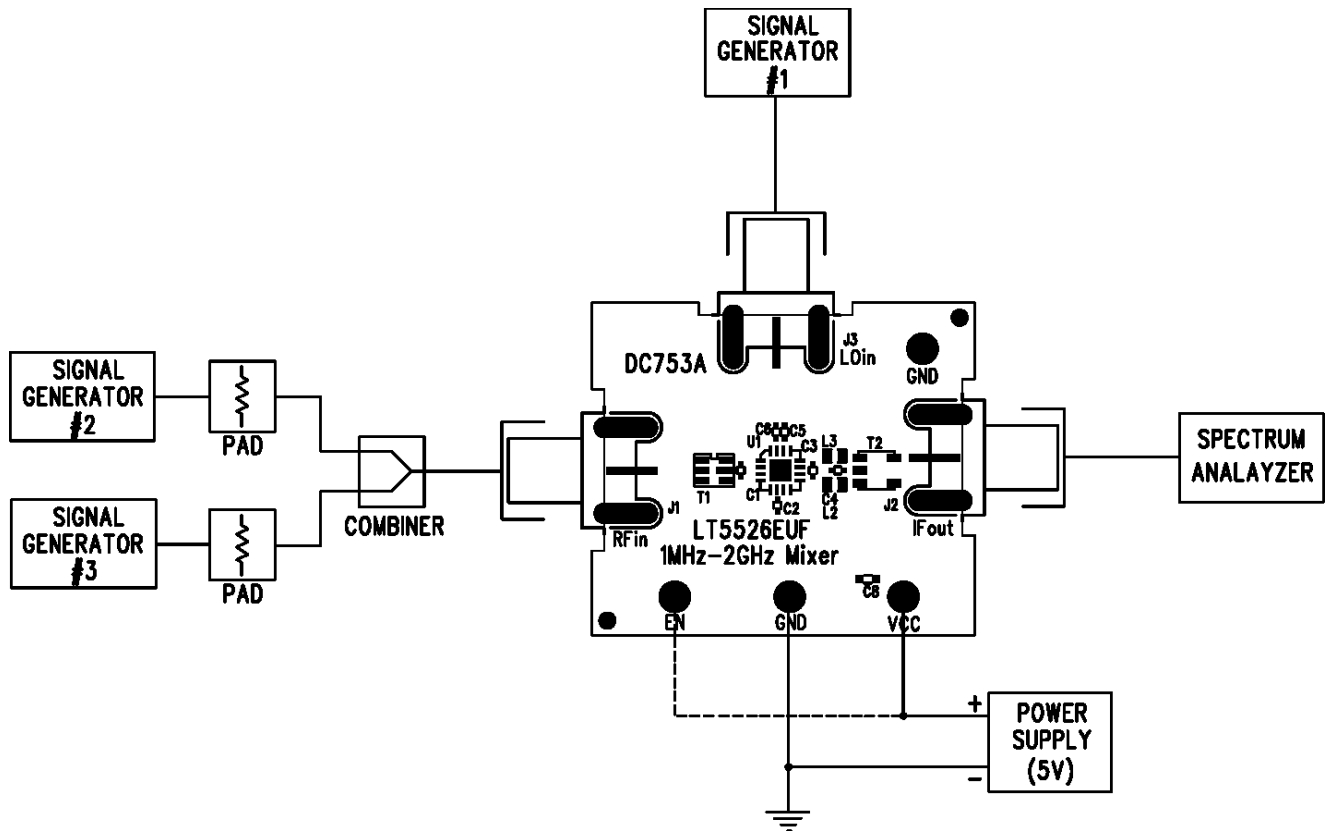
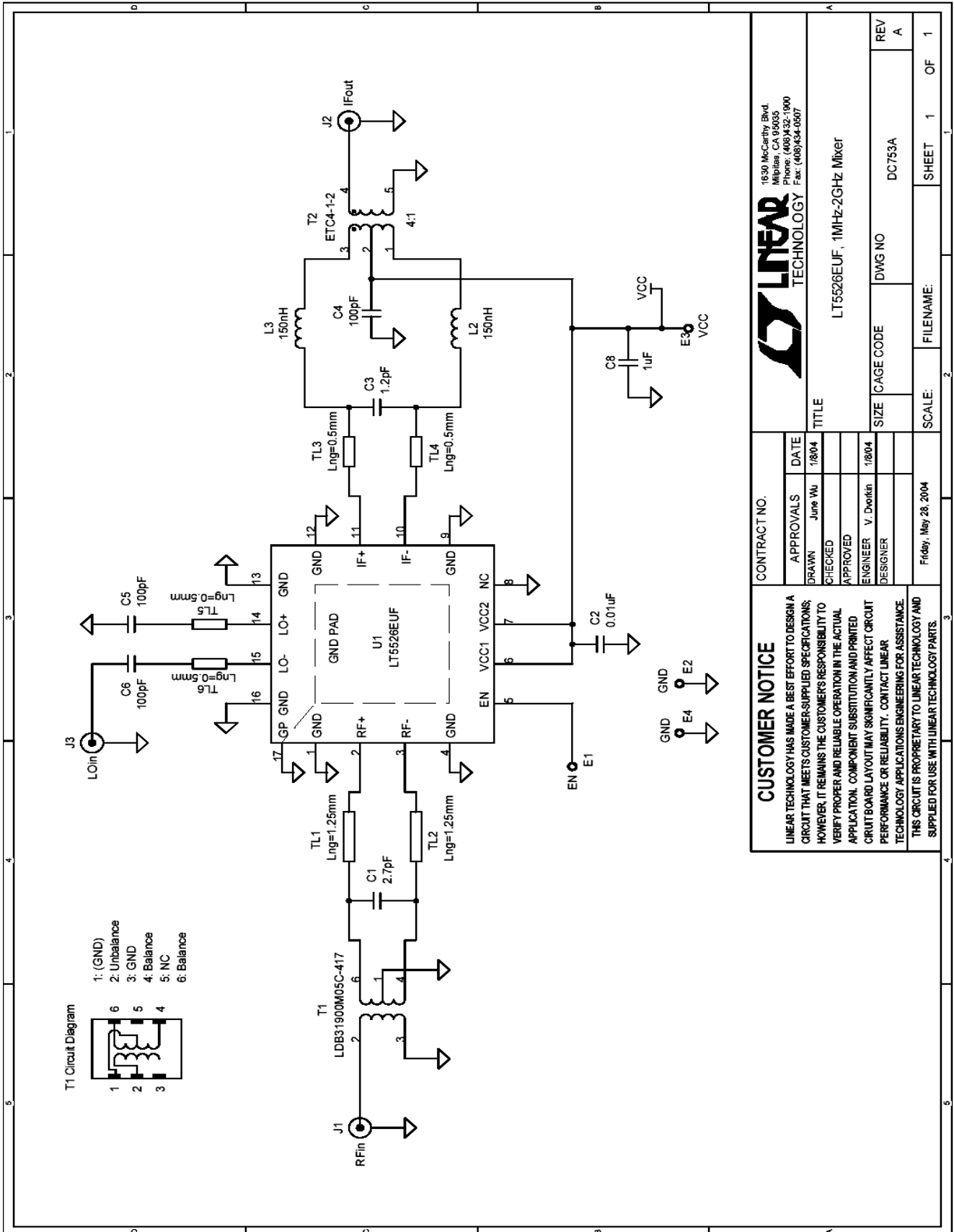

Figure 1. Proper Measurement Equipment Setup

QUICK START GUIDE FOR DEMONSTRATION CIRCUIT 753

900MHZ HIGH LINEARITY, LOW POWER DOWNCONVERTING MIXER



		1830 McCarthy Blvd. Milpitas, CA 95035 Phone: (408)432-1900 Fax: (408)434-0607	
		TITLE LT5526EUF, 1MHz-2GHz Mixer	
CONTRACT NO.	APPROVALS	DATE	REV
	DRAWN	June 14	1/804
	CHECKED		
	APPROVED		
	ENGINEER	V. Dworkin	1/804
	DESIGNER		
	SCALE:	FILENAME:	SHEET 1 OF 1
			REV A
			DC753A
			DWG NO
			SIZE
			CAGE CODE

CUSTOMER NOTICE

LINEAR TECHNOLOGY HAS MADE A BEST EFFORT TO DESIGN A CIRCUIT THAT MEETS CUSTOMER-SUPPLIED SPECIFICATIONS. HOWEVER, IT REMAINS THE CUSTOMER'S RESPONSIBILITY TO VERIFY PROPER AND RELIABLE OPERATION IN THE ACTUAL APPLICATION. COMPONENT SUBSTITUTION AND PRINTED CIRCUIT BOARD LAYOUT MAY SIGNIFICANTLY AFFECT CIRCUIT PERFORMANCE OR RELIABILITY. CONTACT LINEAR TECHNOLOGY APPLICATIONS ENGINEERING FOR ASSISTANCE.

THIS CIRCUIT IS PROPRIETARY TO LINEAR TECHNOLOGY AND SUPPLIED FOR USE WITH LINEAR TECHNOLOGY PARTS.

X-ON Electronics

Largest Supplier of Electrical and Electronic Components

Click to view similar products for [RF Development Tools](#) category:

Click to view products by [Analog Devices](#) manufacturer:

Other Similar products are found below :

[MAAM-011117](#) [MAAP-015036-DIEEV2](#) [EV1HMC1113LP5](#) [EV1HMC6146BLC5A](#) [EV1HMC637ALP5](#) [EVAL-ADG919EBZ](#) [ADL5363-EVALZ](#) [LMV228SDEVAL](#) [SKYA21001-EVB](#) [SMP1331-085-EVB](#) [EV1HMC618ALP3](#) [EVAL01-HMC1041LC4](#) [MAAL-011111-000SMB](#) [MAAM-009633-001SMB](#) [MASW-000936-001SMB](#) [107712-HMC369LP3](#) [107780-HMC322ALP4](#) [SP000416870](#) [EV1HMC470ALP3](#) [EV1HMC520ALC4](#) [EV1HMC244AG16](#) [MAX2614EVKIT#](#) [124694-HMC742ALP5](#) [SC20ASATEA-8GB-STD](#) [MAX2837EVKIT+](#) [MAX2612EVKIT#](#) [MAX2692EVKIT#](#) [EV1HMC629ALP4E](#) [SKY12343-364LF-EVB](#) [108703-HMC452QS16G](#) [EV1HMC863ALC4](#) [119197-HMC658LP2](#) [EV1HMC647ALP6](#) [ADL5725-EVALZ](#) [106815-HMC441LM1](#) [EV1HMC1018ALP4](#) [UXN14M9PE](#) [MAX2016EVKIT](#) [EV1HMC939ALP4](#) [MAX2410EVKIT](#) [MAX2204EVKIT+](#) [EV1HMC8073LP3D](#) [SIMSA868-DKL](#) [SIMSA868C-DKL](#) [SKY65806-636EK1](#) [SKY68020-11EK1](#) [SKY67159-396EK1](#) [SKY66181-11-EK1](#) [SKY65804-696EK1](#) [SKY13396-397LF-EVB](#)