

QUICK START GUIDE FOR DEMONSTRATION CIRCUIT 768

15A POLYPHASE MONOLITHIC SYNCHRONOUS BUCK REGULATOR

LTC3415

DESCRIPTION

Demonstration Circuit 768 is a 15A high efficiency, phase lockable constant frequency buck converter, incorporating two LTC3415 polyphase monolithic synchronous regulators. The DC768 has an input voltage range of 2.5V to 5.5V and an output voltage range from 0.6V to 5V. The reference voltage of 0.6V is +/-1% accurate, producing a more precise output voltage. The operating frequency range of the DC768 is either set by the LTC3415 internal oscillator to 1.5 MHz, set to 1 MHz or 2 MHz by forcing the PLLPF pin to ground or V_{IN} , respectively, or synchronized to an external clock, with a range between 750 kHz and 2.25 MHz. The DC768 can deliver high power for monolithic parts – up to 15A of output current – due to the high current power switches (28 m Ω of on-state resistance) of the LTC3415. The LTC3415 also incorporates OPTI-LOOP compensation, so that the DC768 can be optimized with external components to provide fast transient response over a wide range of line and load conditions. However, the LTC3415 has internal compensation for those requiring a

simple high power supply only. The DC768 has two LTC3415s operating in polyphase operation. Due to the LTC3415 polyphase capability, multiple DC768s can be paralleled for higher current power supplies. Since the parallel LTC3415s operate out-of-phase, the amount of input and output capacitance required will be minimal. The DC768 offers the three standard modes of operation: force continuous, pulse-skipping, and Burst-Mode™, for those circuits that operate during intervals of low output power. Extra features include tracking, for easy power supply sequencing, output margining, power good, and spread spectrum operation, which significantly reduces the peak switching noise emitted from the DC768. All these features make the DC768 perfectly suited for high current, high power applications, such as notebook or desktop computers.

Design files for this circuit board are available. Call the LTC factory.

™ - Burst Mode is a trademark of Linear Technology Corporation

Table 1.

Performance Summary ($T_A = 25^\circ\text{C}$)

PARAMETER	CONDITIONS	VALUE
Minimum Input Voltage		2.5V
Maximum Input Voltage		5.5V
Output Voltage V_{OUT} Regulation	$V_{IN} = 2.5\text{V to } 5.5\text{V}$, $I_{OUT} = 0\text{A to } 15\text{A}$	1.2V $\pm 3\%$ (1.164V to 1.236V) 1.5V $\pm 3\%$ (1.455V to 1.545V) 1.8V $\pm 3\%$ (1.746V to 1.854V)
Typical Output Ripple V_{OUT}	$V_{IN} = 5\text{V}$, $I_{OUT} = 15\text{A}$ (20 MHz BW)	<20mV _{p-p}
Operation Modes	Burst Mode - $V_{IN} = 3.3\text{V}$, $V_{OUT} = 1.8\text{V}$	<1.5A $\pm 0.1\text{A}$
	Pulse-Skipping - $V_{IN} = 3.3\text{V}$, $V_{OUT} = 1.8\text{V}$	< 5A $\pm 0.1\text{A}$
	Forced Continuous	Any Output Current
Nominal Switching Frequency		1.5 MHz

QUICK START PROCEDURE

Demonstration Circuit 768 is easy to set up to evaluate the performance of the LTC3415. For proper measurement equipment configuration, set up the circuit according to the diagram in **Figure 1**. Before proceeding to test, make sure the jumper shunts are in the appropriate header according to the legend in **Figure 1**, except for one exception: insert jumper JP5 shunt into the off position, which connects the RUN pin to ground (GND), and thus, shuts down the circuit.

NOTE: When measuring the input or output voltage ripple, care must be taken to avoid a long ground lead on the oscilloscope probe. Measure the input or output voltage ripple by touching the probe tip directly across the Vin or Vout and GND terminals. See **Figure 2** for proper scope probe technique.

1. With the DC768 set up according to the proper measurement and equipment in **Figure 1**, apply 3.3V at Vin (Do not hot-plug Vin or increase Vin over the rated maximum supply voltage of 5.5V, or the part may be damaged.). Measure Vout; it should read 0V. If desired, one can measure the shutdown supply current at this point. The supply current will be approximately 400 uA, or less, in shutdown.
2. Turn on the circuit by inserting the shunt in header JP5 into the ON position. The output voltage should be regulating. Measure Vout - it should measure 1.2V +/- 1.5% (1.182V to 1.218V).

3. Vary the input voltage from 2.5V to 5.5V and adjust the load current from 0 to 15A. Vout should read between 1.2V +/- 3% (1.164V to 1.236V).
4. Measure the output ripple voltage at any output current level; it usually will measure less than 20 mVAC.
5. Observe the voltage waveform at the switch node. Verify the switching frequency is between 1.3 MHz and 1.7 MHz ($T = 0.769 \mu\text{s}$ and $0.588 \mu\text{s}$), and that the switch node waveform is rectangular in shape.

Insert jumper JP5 shunt into the OFF position and move the 1.2V Vout shunt into any of the remaining output voltage options: 1.5V or 1.8V. Just as in the 1.2Vout test, the output voltage should read Vout +/- 1.5% tolerance under static line and load conditions, and another +/- 1.5% tolerance under dynamic line and load conditions (+/- 3% total).

The Burst-Mode™ or pulse-skipping operation modes of the LTC3415 can also be observed now by changing the position of the shunt in header JP7. 1 or 2 MHz operating frequencies can be activated by re-positioning the JP6 shunt. The tables below show the extra features, such as margining and spread spectrum.

When finished, turn off the circuit (connecting the RUN pin to ground) by inserting the shunt in header JP5 into the OFF position.

QUICK START GUIDE FOR DEMONSTRATION CIRCUIT 768

15A POLYPHASE MONOLITHIC SYNCHRONOUS BUCK REGULATOR

PARAMETER	CONDITIONS	VALUE
CLOCKOUT	PHMODE Pin Pulled to V_{IN} - $V_{IN} = 3.3V$, $V_{OUT} = 1.8V$	1.5 MHz
CLOCKIN	CLOCKIN Pin Connected to V_{IN} - $V_{IN} = 3.3V$, $V_{OUT} = 1.8V$	Spread Spectrum (See Photo)
	Synchronized to 2Vpk-to-pk, 2 MHz signal injected into the PLLPF pin - $V_{IN} = 3.3V$, $V_{OUT} = 1.8V$	2 MHz (Measured at SW & CLOCKOUT Pins)

PARAMETER	CONDITIONS	POSITION MGN	POSITION BSEL	VALUE
Margining	$V_{IN} = 3.3V$, $V_{OUT} = 1.8V$, $I_{OUT} = 5A$	MGN+	5%	1.89V $\pm 4\%$ (1.814V to 1.966V)
			10%	1.98V $\pm 4\%$ (1.900V to 2.060V)
			15%	2.07V $\pm 4\%$ (1.987V to 2.153V)
		MGN-	5%	1.71V $\pm 4\%$ (1.641V to 1.779V)
			10%	1.62V $\pm 4\%$ (1.555V to 1.685V)
			15%	1.53V $\pm 4\%$ (1.468V to 1.592V)

QUICK START GUIDE FOR DEMONSTRATION CIRCUIT 768

15A POLYPHASE MONOLITHIC SYNCHRONOUS BUCK REGULATOR

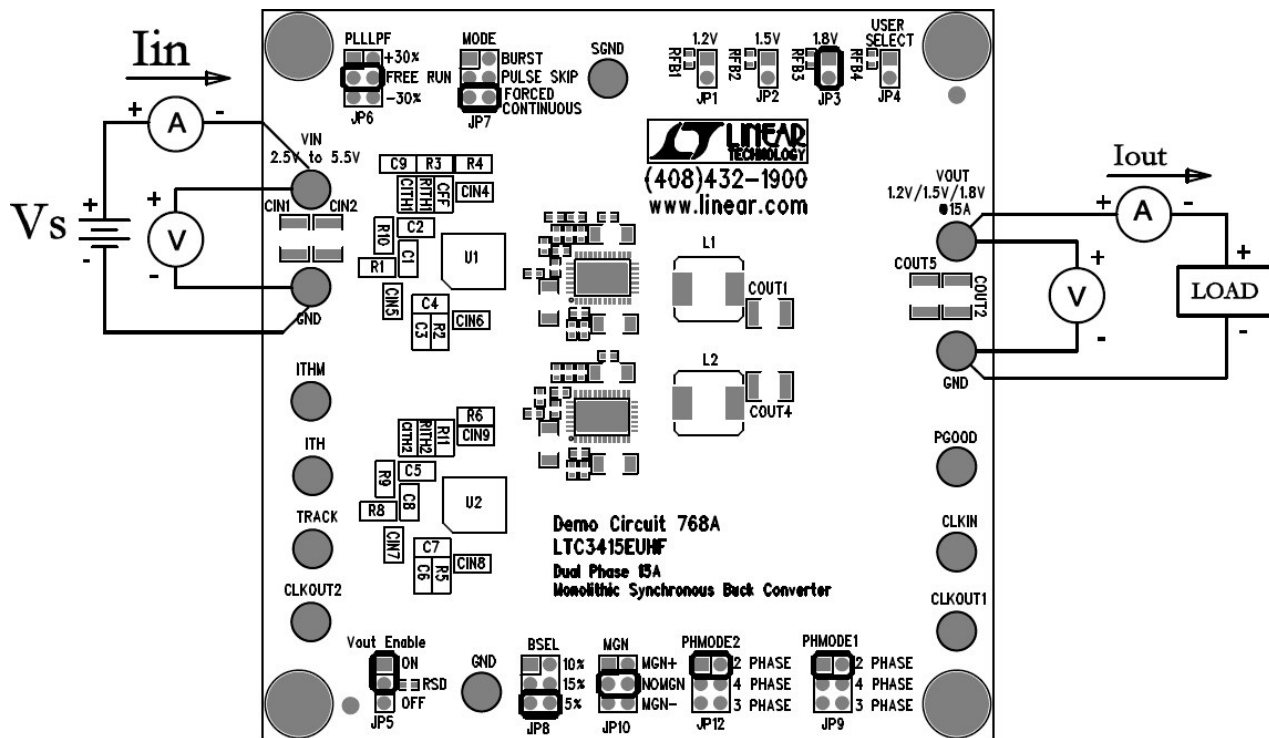

Figure 1. Proper Measurement Equipment Setup

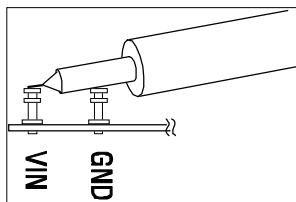

Figure 2. Measuring Input or Output Ripple

QUICK START GUIDE FOR DEMONSTRATION CIRCUIT 768

15A POLYPHASE MONOLITHIC SYNCHRONOUS BUCK REGULATOR

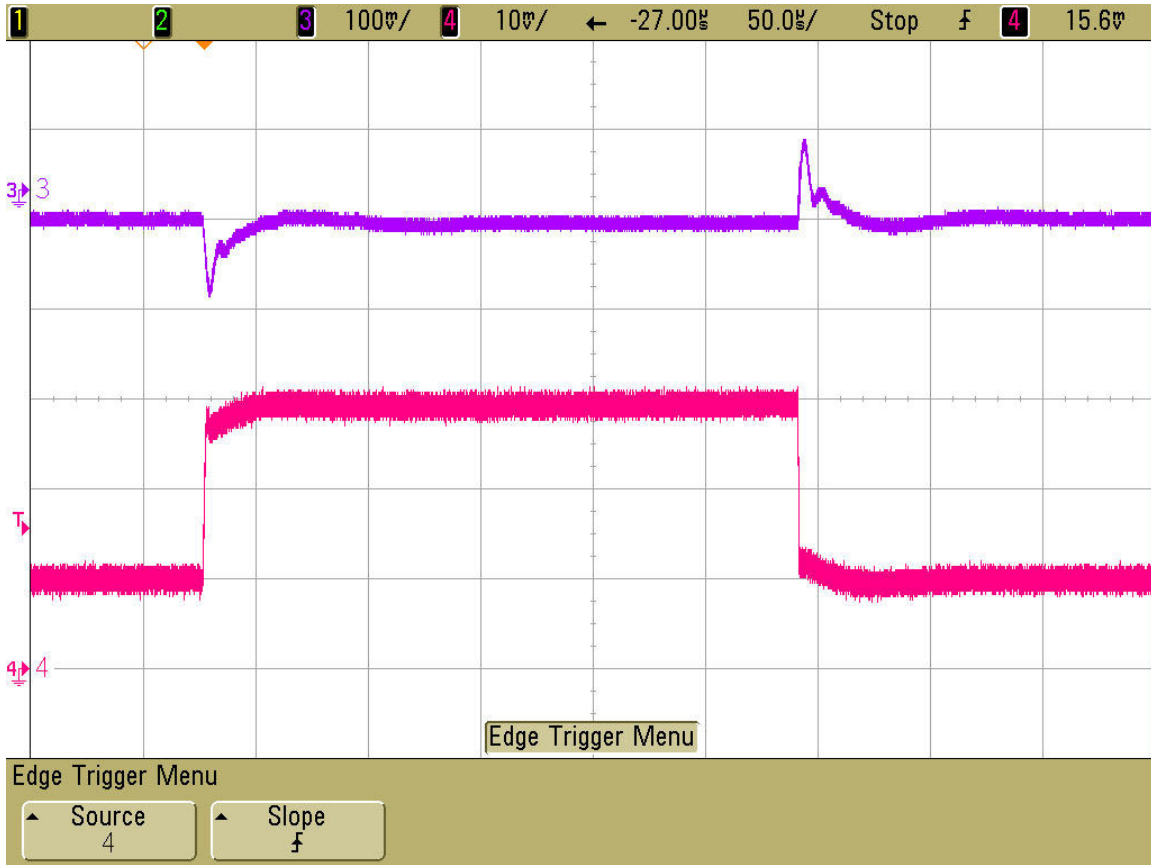

Figure 3. Load Step Response
 $V_{IN} = 3.3V$, $V_{OUT} = 1.8V$ & 10A Load Step
Trace 1: Output Voltage (100mV/div AC)
Trace 2: Output Current (5A/div)

QUICK START GUIDE FOR DEMONSTRATION CIRCUIT 768

15A POLYPHASE MONOLITHIC SYNCHRONOUS BUCK REGULATOR

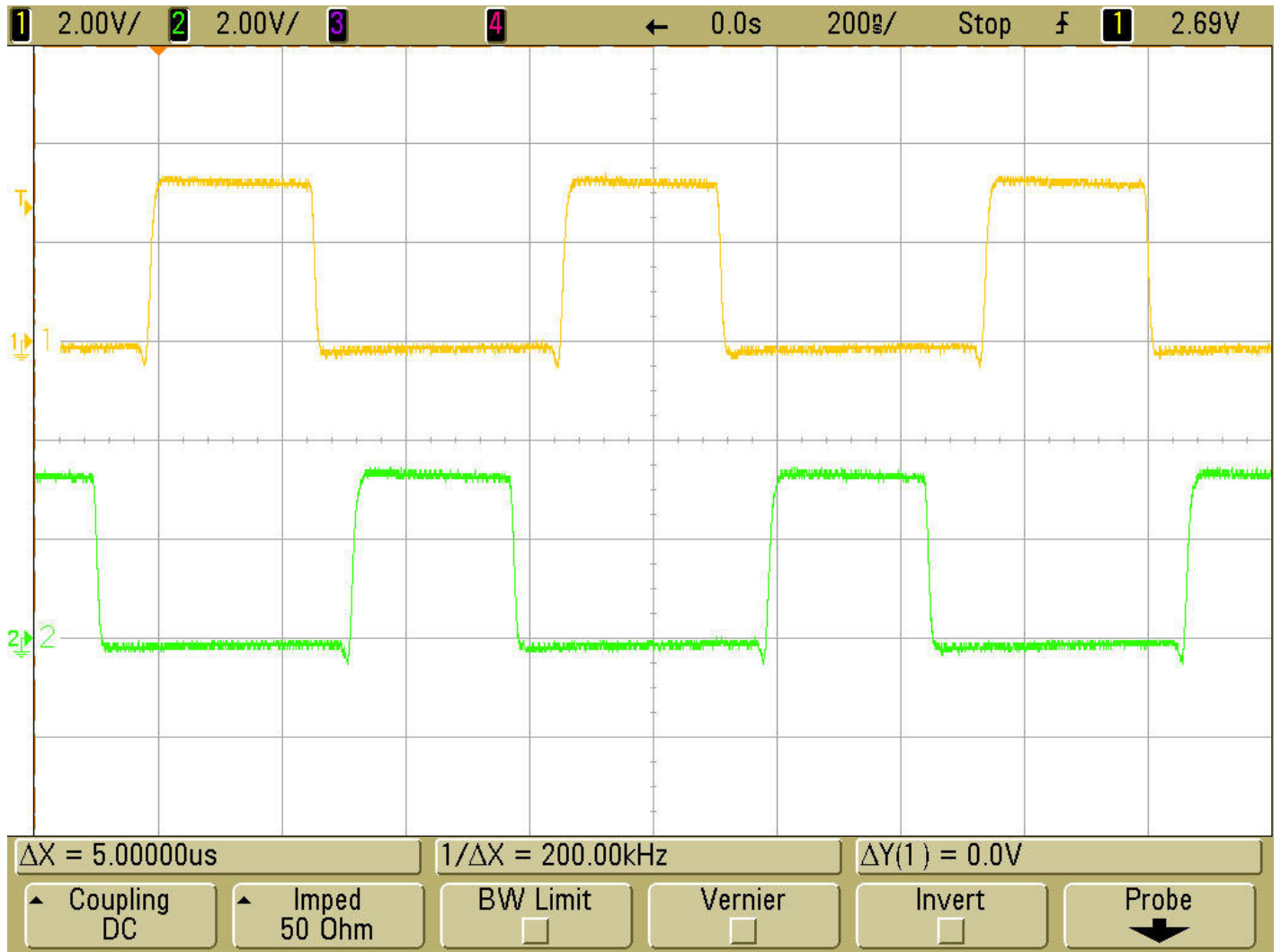
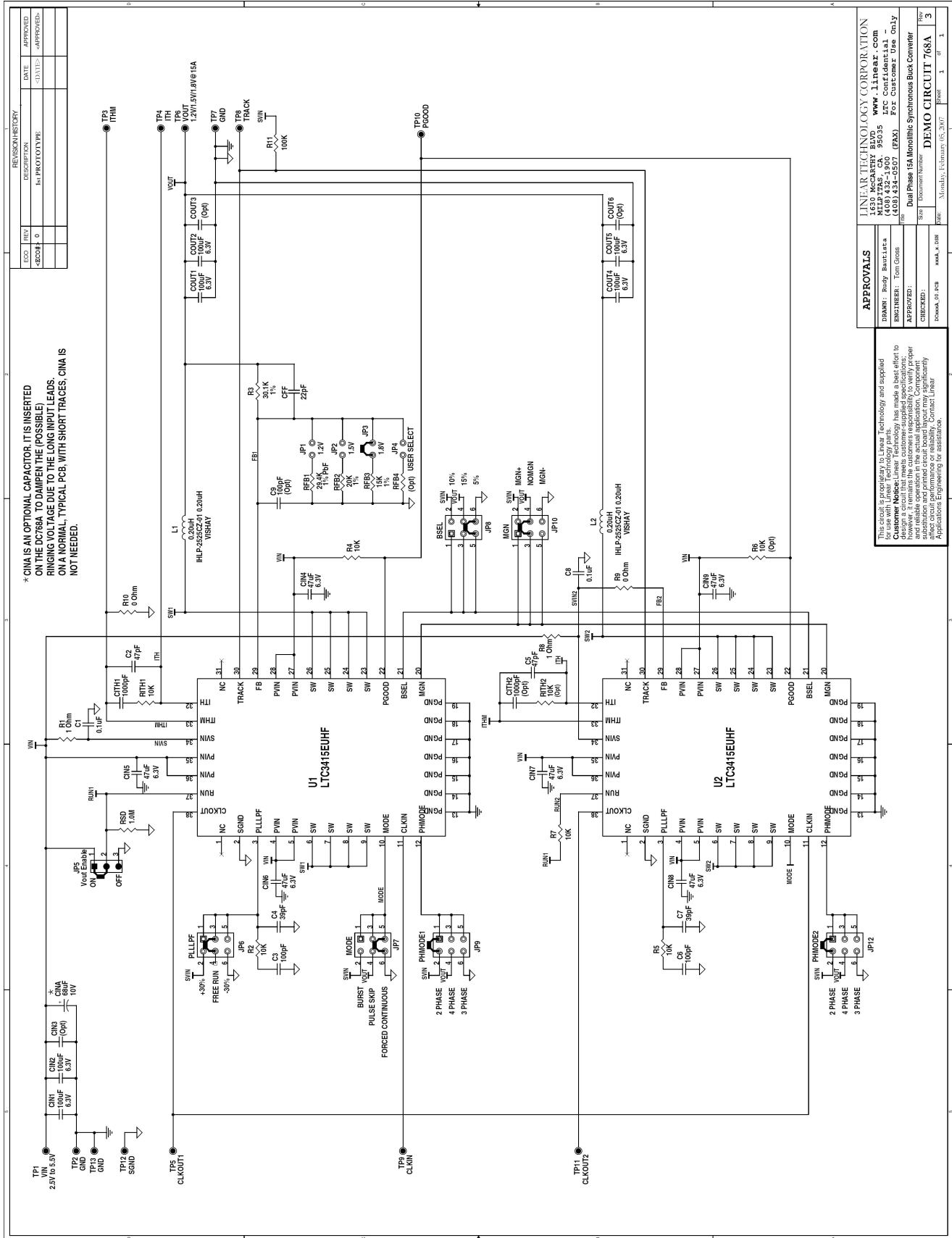

Figure 4. 180° Out-of-Phase Switching Operation

$V_{IN} = 3.3V$, $V_{OUT} = 1.2V$, $I_{OUT} = 5A$

QUICK START GUIDE FOR DEMONSTRATION CIRCUIT 768

15A POLYPHASE MONOLITHIC SYNCHRONOUS BUCK REGULATOR



X-ON Electronics

Largest Supplier of Electrical and Electronic Components

Click to view similar products for [Power Management IC Development Tools](#) category:

Click to view products by [Analog Devices](#) manufacturer:

Other Similar products are found below :

[EVAL-ADM1168LQEBZ](#) [EVB-EP5348UI](#) [MIC23451-AAAYFL EV](#) [MIC5281YMME EV](#) [DA9063-EVAL](#) [ADP122-3.3-EVALZ](#) [ADP130-0.8-EVALZ](#) [ADP130-1.2-EVALZ](#) [ADP130-1.5-EVALZ](#) [ADP130-1.8-EVALZ](#) [ADP1714-3.3-EVALZ](#) [ADP1716-2.5-EVALZ](#) [ADP1740-1.5-EVALZ](#) [ADP1752-1.5-EVALZ](#) [ADP1828LC-EVALZ](#) [ADP1870-0.3-EVALZ](#) [ADP1871-0.6-EVALZ](#) [ADP1873-0.6-EVALZ](#) [ADP1874-0.3-EVALZ](#) [ADP1882-1.0-EVALZ](#) [ADP199CB-EVALZ](#) [ADP2102-1.25-EVALZ](#) [ADP2102-1.875EVALZ](#) [ADP2102-1.8-EVALZ](#) [ADP2102-2-EVALZ](#) [ADP2102-3-EVALZ](#) [ADP2102-4-EVALZ](#) [ADP2106-1.8-EVALZ](#) [ADP2147CB-110EVALZ](#) [AS3606-DB](#) [BQ24010EVM](#) [BQ24075TEVM](#) [BQ24155EVM](#) [BQ24157EVM-697](#) [BQ24160EVM-742](#) [BQ24296MEVM-655](#) [BQ25010EVM](#) [BQ3055EVM](#) [NCV891330PD50GEVB](#) [ISLUSBI2CKIT1Z](#) [LM2744EVAL](#) [LM2854EVAL](#) [LM3658SD-AEV/NOPB](#) [LM3658SDEV/NOPB](#) [LM3691TL-1.8EV/NOPB](#) [LM4510SDEV/NOPB](#) [LM5033SD-EVAL](#) [LP38512TS-1.8EV](#) [EVAL-ADM1186-1MBZ](#) [EVAL-ADM1186-2MBZ](#)