

DESCRIPTION

Demonstration circuit DC770C is a DC/DC boost converter featuring the LT3782A constant frequency current mode boost controller. The DC770C operates over 10V to 28V input and provides 4A of output current at 50V output. The 250kHz constant frequency operation results in a small and efficient circuit. The converter provides high output voltage accuracy (typically $\pm 3\%$) over wide load range with no minimum load requirement.

The demonstration circuit can be easily modified to generate different output voltages. Please consult LTC factory for details.

The DC770C has a small circuit footprint. It is a high performance and cost effective solution for Telecom, Automotive and Power-Over-Ethernet applications.

Design files for this circuit board are available. Call the LTC factory.

LT is a trademark of Linear Technology Corporation

QUICK START PROCEDURE

Demonstration circuit DC770C is easy to set up to evaluate the performance of the LT3782A. For proper measurement equipment setup refer to Figure 1 and follow the procedure below:

NOTE: When measuring the input or output voltage ripple, care must be taken to minimize the length of the oscilloscope probe ground lead. Measure the input or output voltage ripple by connecting the probe tip directly across the VIN or VOUT and GND terminals as shown in Figure 2.

1. With power off, connect the input power supply to VIN and GND.
2. Check the Vcc Bias voltage-setting jumper JP3. Move it to the VIN position if required.
3. Turn the input power source on and slowly increase the input voltage. Be careful not to exceed 28V.

NOTE: Make sure that the input voltage VIN does not exceed 28V. If higher operating voltage is required, power components with higher voltage ratings should be used. Also, Jumper JP3 will have to be moved to the 15V position.

4. Check for the proper output voltage of 50V.
If there is no output, temporarily disconnect the load to make sure that the load is not set too high.
5. Once the proper output voltage is established, adjust the load within the 4A range and observe the output voltage regulation, ripple voltage, efficiency and other parameters

PROGRAMMING OF SYNCHRONOUS RECTIFIER DELAY

If synchronous rectifier MOSFETs are used, the delay of outputs SGATE1 and SGATE2 can be programmed by the voltage on the DELAY pin.

In that case, the DELAY pin voltage can be derived from the R_{SET} pin. The R_{SET} pin generates a 2.3V reference voltage that can be divided down to the desired value by resistors R_9 and R_{13} .

Keep in mind that $R_9 + R_{13}$ are used to set the switching frequency. In order to keep frequency constant, $R_9 + R_{13}$ should stay constant as well. Please refer to the data sheet for more information.

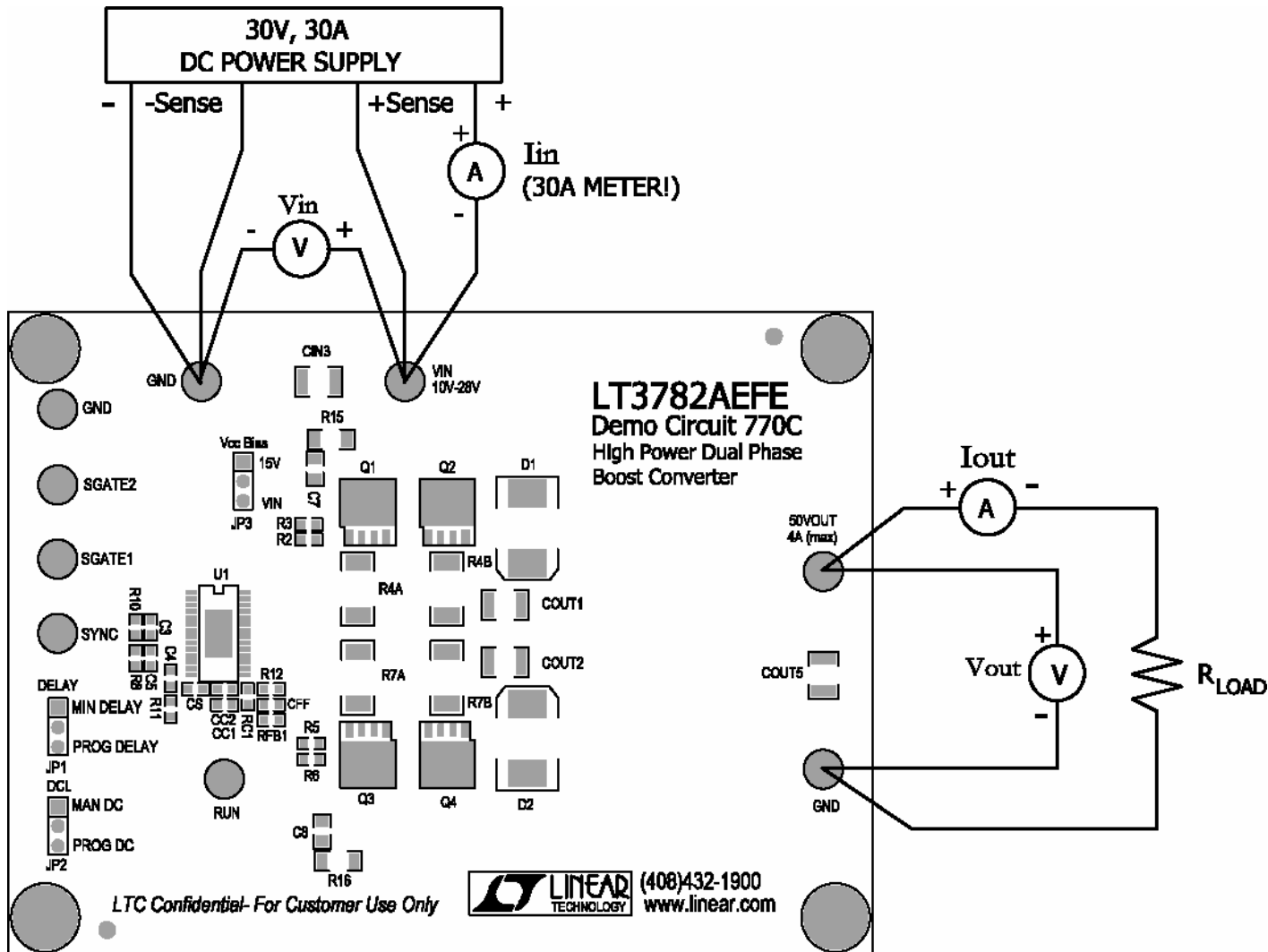

Figure 1. Proper Measurement Equipment Setup

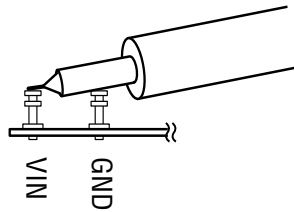
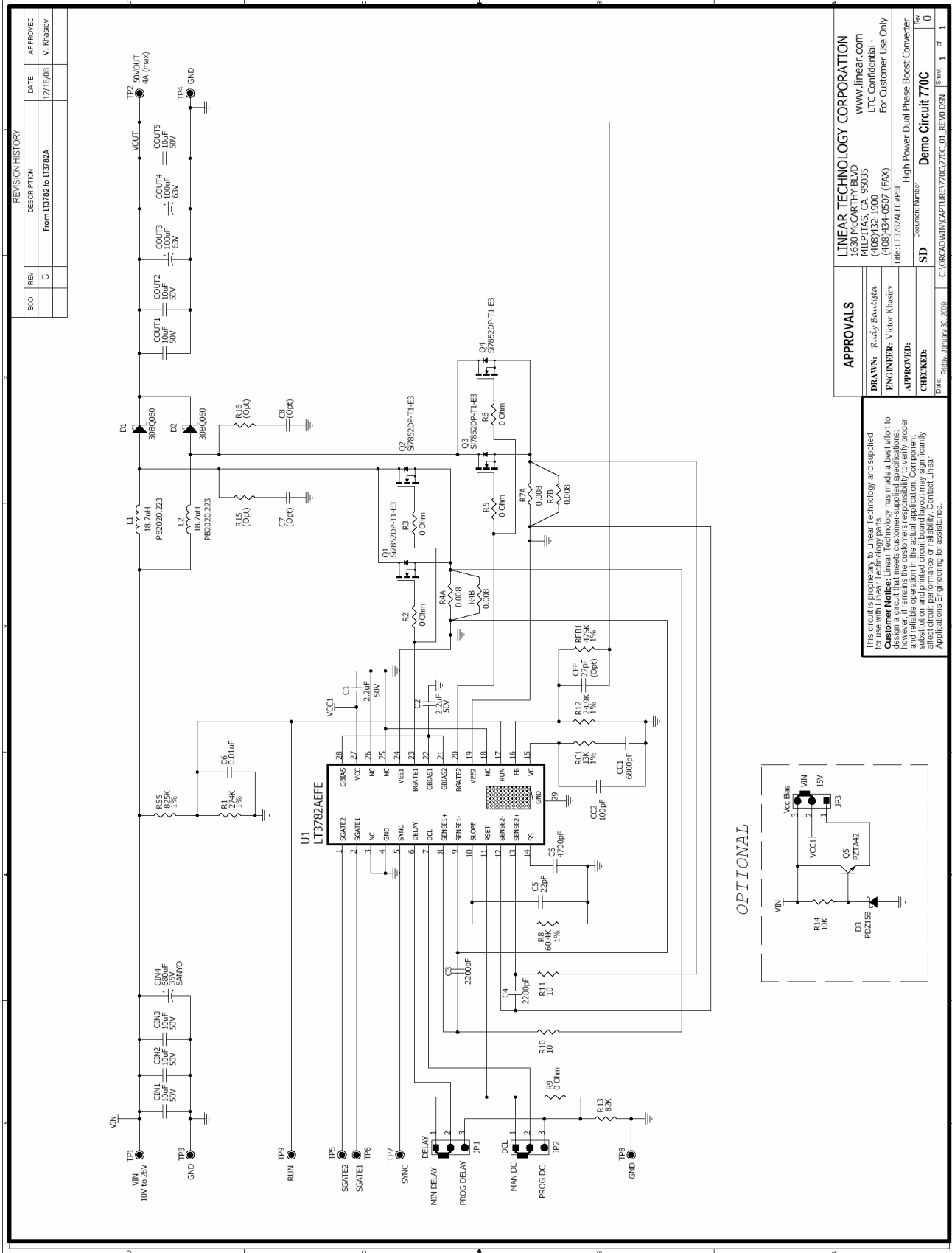

Figure 2. Measuring Input or Output Ripple

QUICK START GUIDE FOR DEMONSTRATION CIRCUIT 770C



REVISION HISTORY		
ECO	REV	DESCRIPTION
	C	From L13782 to L13782A

DATE	APPROVED
12/18/08	V. Khashev

APPROVALS	
DRAWN:	Ready Rouds
ENGINEER:	Victor Khashev
APPROVED:	
CHECKED:	
Document Number	High Power Dual Phase Boost Converter
SD	Demo Circuit 770C
Date: 04/04/09	Sheet 1 of 1

This circuit is proprietary to Linear Technology and supplied for use with Linear Technology parts.
Customer Notice: Linear Technology has made a best effort to ensure that the information in this document is accurate and reliable operation in the actual application. Component values are shown for illustrative purposes only and may significantly affect circuit performance or reliability. Contact Linear Technology Applications Engineering for assistance.

LINEAR TECHNOLOGY CORPORATION
 1650 McCARTHY BLVD
 MILPITAS, CA 95035
 (408) 943-1900
 (408) 943-6507 (FAX)
 Title: L13782AEFE-PPB

APPROVALS
 DRAWN: Ready Rouds
 ENGINEER: Victor Khashev
 APPROVED:
 CHECKED:

Document Number: High Power Dual Phase Boost Converter
 SD: Demo Circuit 770C
 Date: 04/04/09 Sheet 1 of 1

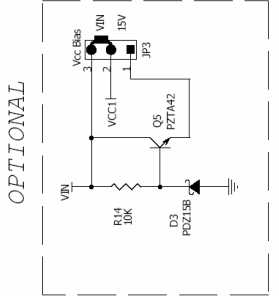

X-ON Electronics

Largest Supplier of Electrical and Electronic Components

Click to view similar products for [Power Management IC Development Tools](#) category:

Click to view products by [Analog Devices](#) manufacturer:

Other Similar products are found below :

[EVAL-ADM1168LQEBZ](#) [EVB-EP5348UI](#) [MIC23451-AAAYFL EV](#) [MIC5281YMME EV](#) [DA9063-EVAL](#) [ADP122-3.3-EVALZ](#) [ADP130-0.8-EVALZ](#) [ADP130-1.2-EVALZ](#) [ADP130-1.5-EVALZ](#) [ADP130-1.8-EVALZ](#) [ADP1714-3.3-EVALZ](#) [ADP1716-2.5-EVALZ](#) [ADP1740-1.5-EVALZ](#) [ADP1752-1.5-EVALZ](#) [ADP1828LC-EVALZ](#) [ADP1870-0.3-EVALZ](#) [ADP1871-0.6-EVALZ](#) [ADP1873-0.6-EVALZ](#) [ADP1874-0.3-EVALZ](#) [ADP1882-1.0-EVALZ](#) [ADP199CB-EVALZ](#) [ADP2102-1.25-EVALZ](#) [ADP2102-1.875EVALZ](#) [ADP2102-1.8-EVALZ](#) [ADP2102-2-EVALZ](#) [ADP2102-3-EVALZ](#) [ADP2102-4-EVALZ](#) [ADP2106-1.8-EVALZ](#) [ADP2147CB-110EVALZ](#) [AS3606-DB](#) [BQ24010EVM](#) [BQ24075TEVM](#) [BQ24155EVM](#) [BQ24157EVM-697](#) [BQ24160EVM-742](#) [BQ24296MEVM-655](#) [BQ25010EVM](#) [BQ3055EVM](#) [NCV891330PD50GEVB](#) [ISLUSBI2CKIT1Z](#) [LM2744EVAL](#) [LM2854EVAL](#) [LM3658SD-AEV/NOPB](#) [LM3658SDEV/NOPB](#) [LM3691TL-1.8EV/NOPB](#) [LM4510SDEV/NOPB](#) [LM5033SD-EVAL](#) [LP38512TS-1.8EV](#) [EVAL-ADM1186-1MBZ](#) [EVAL-ADM1186-2MBZ](#)