

DESCRIPTION

Demonstration circuits 826C-A and 826C-B feature the [LTC®2950-2](#) and the [LTC2951-2](#) respectively, which are low power, wide input voltage range, pushbutton on/off controllers. A pushbutton switch shorts the \overline{PB} pin to ground which in turn sets the \overline{EN} pin low (see Note 1). Shorting \overline{PB} to ground a second time subsequently resets the \overline{EN} pin high. The \overline{EN} pin is used to connect to a DC/DC converter shutdown to control the turn on and off of the circuit, simulated with a green LED on the DC826C-A/DC826C-B.

JP1 and JP2 on the DC826C-A provide the selection of timing options for the \overline{PB} on and off times. For the DC826C-B, JP1 selects \overline{KILL} times while JP2 selects off

times. JP3 ties and unties \overline{KILL} to \overline{INT} for immediate or delayed turn off. The \overline{INT} status is shown with a red LED. DC826C-A/DC826C-B accepts an input voltage range of 2.7V to 26.4V or a 9V battery for portable demonstration and evaluation.

Note 1: The inversion of \overline{EN} of the LTC2950-2/LTC2951-2 is found in the LTC2950-1/LTC2951-1. Table 1 provides an IC selection guide.

Design files for this circuit board are available at
<http://www.linear.com/demo/DC826C>

LT, LT, LTC, LTM, Linear Technology and the Linear logo are registered trademarks of Linear Technology Corporation. All other trademarks are the property of their respective owners.

IC SELECTION GUIDE

Table 1. LTC2950/LTC2951 Selection Guide (Typical Timing Values, Cap. Adjust = 212ms on DC826C-A/DC826C-B)

PART	ENABLE	ONT	OFFT	KILLT	DEMO BOARD
LTC2950-1	EN	32ms + Cap. Adjust*	32ms + Cap. Adjust*	1000ms	N/A
LTC2950-2	\overline{EN}	32ms + Cap. Adjust*	32ms + Cap. Adjust*	1000ms	DC826C-A
LTC2951-1	EN	128ms	32ms + Cap. Adjust*	128ms + Cap. Adjust*	N/A
LTC2951-2	\overline{EN}	128ms	32ms + Cap. Adjust*	128ms + Cap. Adjust*	DC826C-B

*The additional Cap. Adjust time is selected by an external capacitor. The DC826C-A and DC826C-B adjust times have been pre-selected with a 0.033 μ F capacitor to provide an additional 212ms. The additional time is calculated with the following equations as shown in the LTC2950/LTC2951 data sheets:

$$C_{ONT} = 1.56e-4 [\mu F/ms] \cdot (t_{ONT} - 1ms)$$

$$C_{OFFT} = 1.56e-4 [\mu F/ms] \cdot (t_{OFFT} - 1ms)$$

$$C_{KILLT} = 1.56e-4 [\mu F/ms] \cdot (t_{KILL, OFF DELAY, ADDITIONAL} - 1ms)$$

DEMO MANUAL

DC826C-A/DC826C-B

QUICK START PROCEDURE

Demonstration circuit 826C-A/826C-B is easy to set up to evaluate the performance of the LTC2950-2/LTC2951-2:

1. Place jumpers in the following positions:

JP1: 0.033 μ F

JP2: 0.033 μ F

JP3: UNTIE

2. Connect the input power supply of 2.7V to 26.4V across V_{IN} and GND or a 9V battery to the battery connector.
3. Push and hold the pushbutton once to turn on the green LED.
4. Push and hold the pushbutton again to turn off the green LED.

OPERATING PRINCIPLES

The duration that \overline{PB} must be shorted to ground in order to turn on/off the DC/DC converter is independently programmed (LTC2950-2) by two external capacitors C1 and C2 and selected on the DC826C-A with jumper JP1 and JP2. The status of the \overline{EN} pin, and simulation of the turn on/off of a DC/DC converter, is displayed with green LED D2 on the board.

Figure 1 shows how the \overline{EN} is connected to the \overline{SHDN} pin of a DC/DC converter and how \overline{INT} and \overline{KILL} interfaces with a μ P or μ C. An internal 500ms timer blanks (ignores) the \overline{KILL} signal during system power up. This allows sufficient time for the DC/DC converter and a μ P to perform power up tasks. During turn off, a power down timer provides a delay (LTC2950-2: 1000ms, LTC2951-2: adjustable) from interrupting the μ P (\overline{INT} = low) to turning off the DC/DC converter (\overline{EN} = high). This delay gives the μ P time to perform power down and housekeeping tasks. On the DC826C-B, JP1 selects the power down timer, while JP2 is used to adjust the turn off \overline{PB} duration. The red LED D1 shows the state of the \overline{INT} pin. A μ P can turn off the converter with no delay by asserting \overline{KILL} low. By tying \overline{KILL} to \overline{INT} through JP3, \overline{KILL} is forced low during the \overline{INT} blanking time and thus forces a turn off.

The RC (R_{RPP} and C_{RPP}) at V_{IN} on the DC826 provides reverse polarity protection to the LTC2950-2/LTC2951-2. If power is connected in an application such that the polarities are ensured to be in the correct configuration, this RC may be removed from the circuit.

An additional RC (R_F and C_F), located at the \overline{PB} pin, acts as a filter and is used in an application where the switch is located far from the LTC2950-2/LTC2951-2. In such a case, the RC would be placed next to the switch rather than the part. If the switch is located near the LTC2950-2/LTC2951-2, then the RC may be removed from the circuit.

An LDO (U2) is used on the DC826 to provide a pull-up voltage of 2.6V which is well below the absolute maximum on the \overline{INT} , \overline{EN} , and \overline{KILL} pins for the full range of input voltage of 2.7V to 26.4V. In an application, pull these pins up to a voltage no higher than their rated absolute maximum shown in the data sheet. Optional Zener diodes (D3 – D5) can be used if the pull-up voltage exceeds the rated absolute maximum. (If the interface pins on the DC826C-A /DC826C-B will be pulled up to an external supply, LEDs D1 and D2 should be removed.)

OPERATING PRINCIPLES

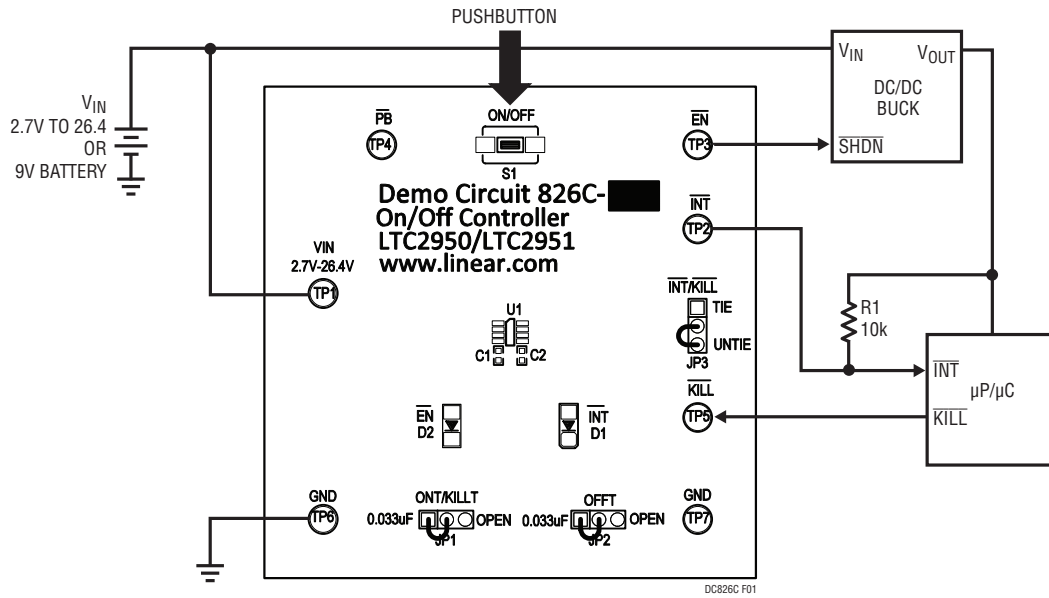
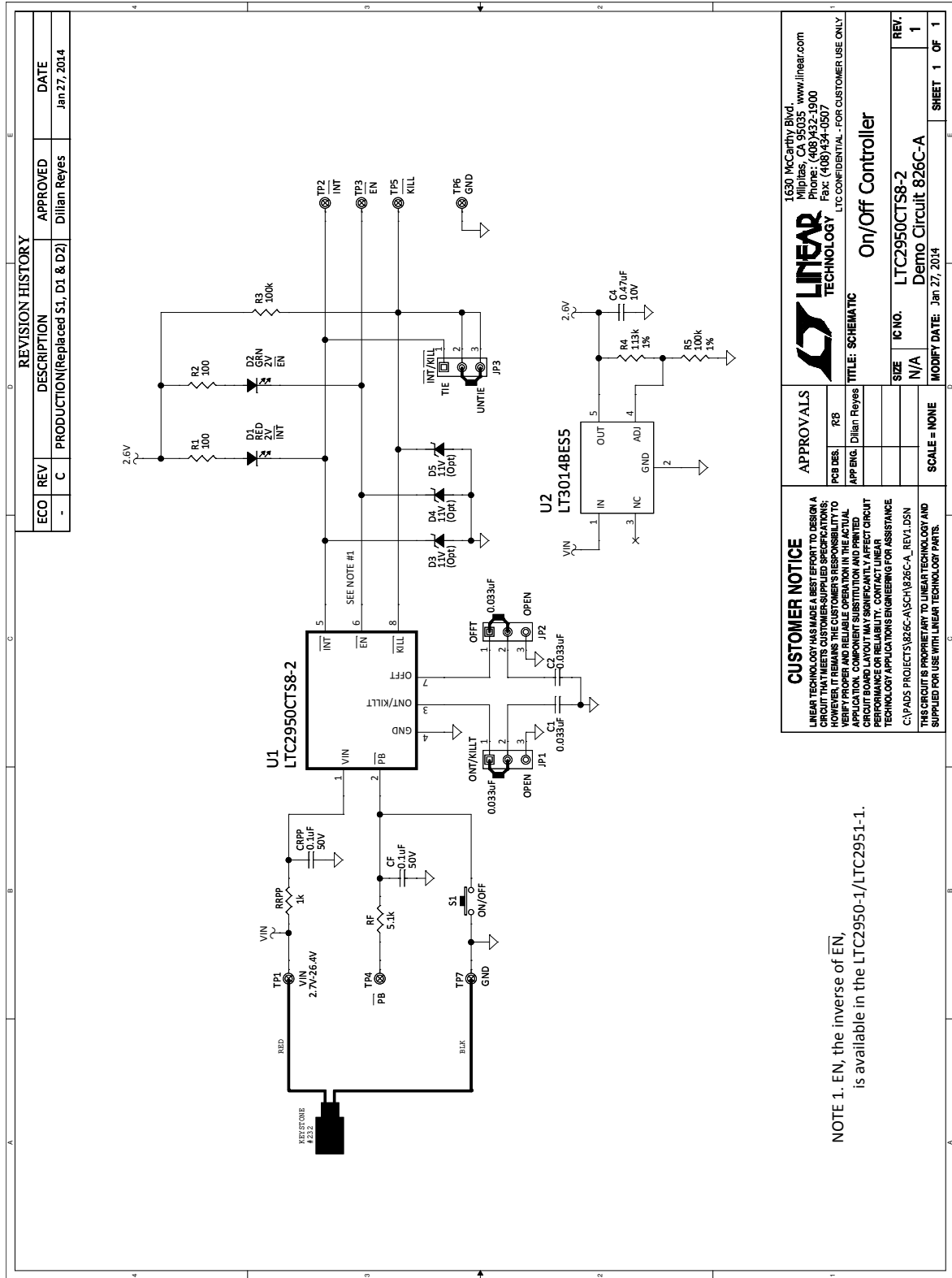

Figure 1. DC826C-A/DC826C-B Example Setup

DEMO MANUAL

DC826C-A/DC826C-B

SCHEMATIC DIAGRAM



NOTE 1. EN, the inverse of EN, is available in the LTC2950-1/LTC2951-1.

SCHEMATIC DIAGRAM

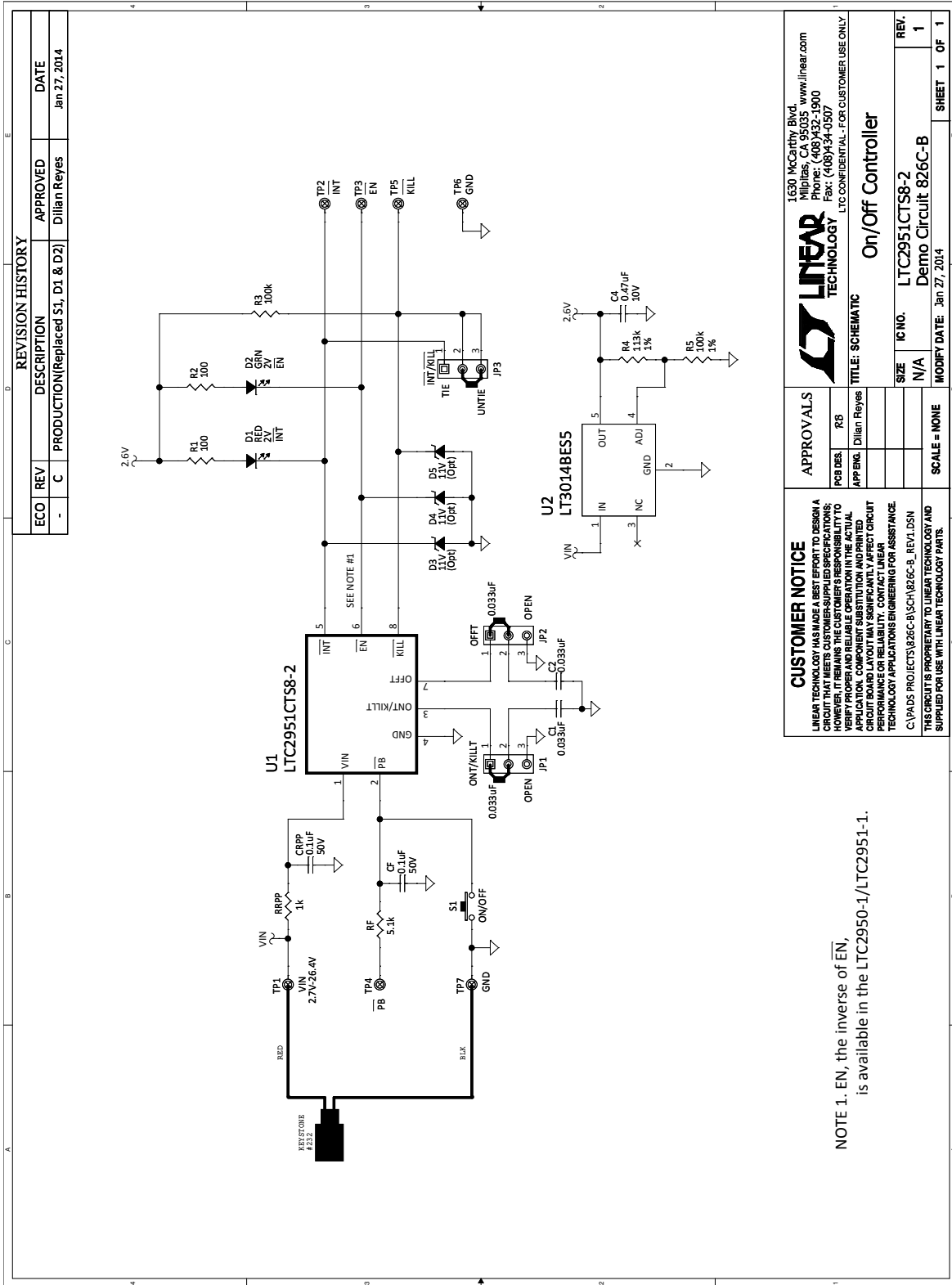

DEMO MANUAL

DC826C-A/DC826C-B

DEMONSTRATION BOARD IMPORTANT NOTICE

Linear Technology Corporation (LTC) provides the enclosed product(s) under the following **AS IS** conditions:

This demonstration board (DEMO BOARD) kit being sold or provided by Linear Technology is intended for use for **ENGINEERING DEVELOPMENT OR EVALUATION PURPOSES ONLY** and is not provided by LTC for commercial use. As such, the DEMO BOARD herein may not be complete in terms of required design-, marketing-, and/or manufacturing-related protective considerations, including but not limited to product safety measures typically found in finished commercial goods. As a prototype, this product does not fall within the scope of the European Union directive on electromagnetic compatibility and therefore may or may not meet the technical requirements of the directive, or other regulations.

If this evaluation kit does not meet the specifications recited in the DEMO BOARD manual the kit may be returned within 30 days from the date of delivery for a full refund. **THE FOREGOING WARRANTY IS THE EXCLUSIVE WARRANTY MADE BY THE SELLER TO BUYER AND IS IN LIEU OF ALL OTHER WARRANTIES, EXPRESSED, IMPLIED, OR STATUTORY, INCLUDING ANY WARRANTY OF MERCHANTABILITY OR FITNESS FOR ANY PARTICULAR PURPOSE. EXCEPT TO THE EXTENT OF THIS INDEMNITY, NEITHER PARTY SHALL BE LIABLE TO THE OTHER FOR ANY INDIRECT, SPECIAL, INCIDENTAL, OR CONSEQUENTIAL DAMAGES.**

The user assumes all responsibility and liability for proper and safe handling of the goods. Further, the user releases LTC from all claims arising from the handling or use of the goods. Due to the open construction of the product, it is the user's responsibility to take any and all appropriate precautions with regard to electrostatic discharge. Also be aware that the products herein may not be regulatory compliant or agency certified (FCC, UL, CE, etc.).

No License is granted under any patent right or other intellectual property whatsoever. **LTC assumes no liability for applications assistance, customer product design, software performance, or infringement of patents or any other intellectual property rights of any kind.**

LTC currently services a variety of customers for products around the world, and therefore this transaction **is not exclusive**.

Please read the DEMO BOARD manual prior to handling the product. Persons handling this product must have electronics training and observe good laboratory practice standards. **Common sense is encouraged.**

This notice contains important safety information about temperatures and voltages. For further safety concerns, please contact a LTC application engineer.

Mailing Address:

Linear Technology
1630 McCarthy Blvd.
Milpitas, CA 95035

Copyright © 2004, Linear Technology Corporation

X-ON Electronics

Largest Supplier of Electrical and Electronic Components

Click to view similar products for [Power Management IC Development Tools](#) category:

Click to view products by [Analog Devices](#) manufacturer:

Other Similar products are found below :

[EVAL-ADM1168LQEBZ](#) [EVB-EP5348UI](#) [MIC23451-AAAYFL EV](#) [MIC5281YMME EV](#) [DA9063-EVAL](#) [ADP122-3.3-EVALZ](#) [ADP130-0.8-EVALZ](#) [ADP130-1.2-EVALZ](#) [ADP130-1.5-EVALZ](#) [ADP130-1.8-EVALZ](#) [ADP1714-3.3-EVALZ](#) [ADP1716-2.5-EVALZ](#) [ADP1740-1.5-EVALZ](#) [ADP1752-1.5-EVALZ](#) [ADP1828LC-EVALZ](#) [ADP1870-0.3-EVALZ](#) [ADP1871-0.6-EVALZ](#) [ADP1873-0.6-EVALZ](#) [ADP1874-0.3-EVALZ](#) [ADP1882-1.0-EVALZ](#) [ADP199CB-EVALZ](#) [ADP2102-1.25-EVALZ](#) [ADP2102-1.875EVALZ](#) [ADP2102-1.8-EVALZ](#) [ADP2102-2-EVALZ](#) [ADP2102-3-EVALZ](#) [ADP2102-4-EVALZ](#) [ADP2106-1.8-EVALZ](#) [ADP2147CB-110EVALZ](#) [AS3606-DB](#) [BQ24010EVM](#) [BQ24075TEVM](#) [BQ24155EVM](#) [BQ24157EVM-697](#) [BQ24160EVM-742](#) [BQ24296MEVM-655](#) [BQ25010EVM](#) [BQ3055EVM](#) [NCV891330PD50GEVB](#) [ISLUSBI2CKIT1Z](#) [LM2744EVAL](#) [LM2854EVAL](#) [LM3658SD-AEV/NOPB](#) [LM3658SDEV/NOPB](#) [LM3691TL-1.8EV/NOPB](#) [LM4510SDEV/NOPB](#) [LM5033SD-EVAL](#) [LP38512TS-1.8EV](#) [EVAL-ADM1186-1MBZ](#) [EVAL-ADM1186-2MBZ](#)