

DESCRIPTION

Demonstration circuit 849 is a 750mA, 1.2MHz Synchronous Boost Converter with Reverse Battery Protection featuring the LTC[®]3499EDD. The demo board demonstrates a DC/DC boost converter, with a 750mA switch current limit, providing a 3.3V output at 250mA from a two cell input voltage, or a 5V output at 170mA from either a two cell or a Li-ion battery. **The LTC3499EDD offers integrated reverse battery protection up to -6V for both the part and the load, drawing typically less than 1uA of current.** The input voltage of this supply can also be increased higher than the output, but thermal limitations reduce the output current that can be delivered. See **Vin>Vout Operation** section on the datasheet. The

circuit also demonstrates the advantages of output disconnect and inrush current limiting. Small circuit size and low component count make the LTC3499EDD suitable for use in many space-conscious applications such as Medical Equipment, Digital Cameras, MP3 Players, and other Portable Devices. Other integrated features include peak current limit, soft-start, antiringing control and thermal shut-down.

Design files for this circuit board are available. Call the LTC factory.

LTC is a trademark of Linear Technology Corporation

Table 1. Performance Summary (T_A = 25°C) 3.3V Output

PARAMETERS	CONDITION	VALUE
Minimum Input Voltage		1.8V
Maximum Input Voltage		3V
Output Voltage V _{OUT}	V _{IN} = 1.8V, I _{OUT} = 0mA to 250mA	3.3V ±3%
Output Voltage V _{OUT}	V _{IN} = 3.0V, I _{OUT} = 0mA to 500mA	3.3V ±3%
Typical Output Ripple V _{OUT}	V _{IN} = 1.8V, I _{OUT} = 250mA	20mV _{P-P}
Typical efficiency	V _{IN} = 2.4V, I _{OUT} = 160mA	90%

Table 2. Performance Summary (T_A = 25°C) 5V Output

PARAMETERS	CONDITION	VALUE
Minimum Input Voltage		1.8V
Maximum Input Voltage		4.2V
Output Voltage V _{OUT}	V _{IN} = 1.8V, I _{OUT} = 0mA to 170mA	5V ±3%
Output Voltage V _{OUT}	V _{IN} = 2.7V, I _{OUT} = 0mA to 270mA	5V ±3%
Output Voltage V _{OUT}	V _{IN} = 4.2V, I _{OUT} = 0mA to 480mA	5V ±3%
Typical Output Ripple V _{OUT}	V _{IN} = 2.7V, I _{OUT} = 270mA	22mV _{P-P}
Typical efficiency	V _{IN} = 2.7V, I _{OUT} = 160mA	88%

QUICK START PROCEDURE

Demonstration circuit 849 is easy to set up to evaluate the performance of the LTC3499EDD. Refer to Figure 1 for proper measurement equipment setup and follow the procedure below:

NOTE: When measuring the input or output voltage ripple, care must be taken to avoid a long ground lead on the oscilloscope probe. Measure the input or output voltage ripple by touching the probe tip directly across the VIN or VOUT and GND terminals. See Figure 2 for proper scope probe technique.

1. Place jumpers in the following positions:

JP1 Run.

JP2 3.3V or 5V (depending on output desired)

2. With power off, connect the input power supply to VIN and GND.
3. Turn on the power at the input.
4. Check for the proper output voltages.

NOTE: If there is no output, temporarily disconnect the load to make sure that the load is not set too high.

NOTE: Once the proper output voltages are established, adjust the loads within the operating range and observe the output voltage regulation, ripple voltage, efficiency and other parameters.

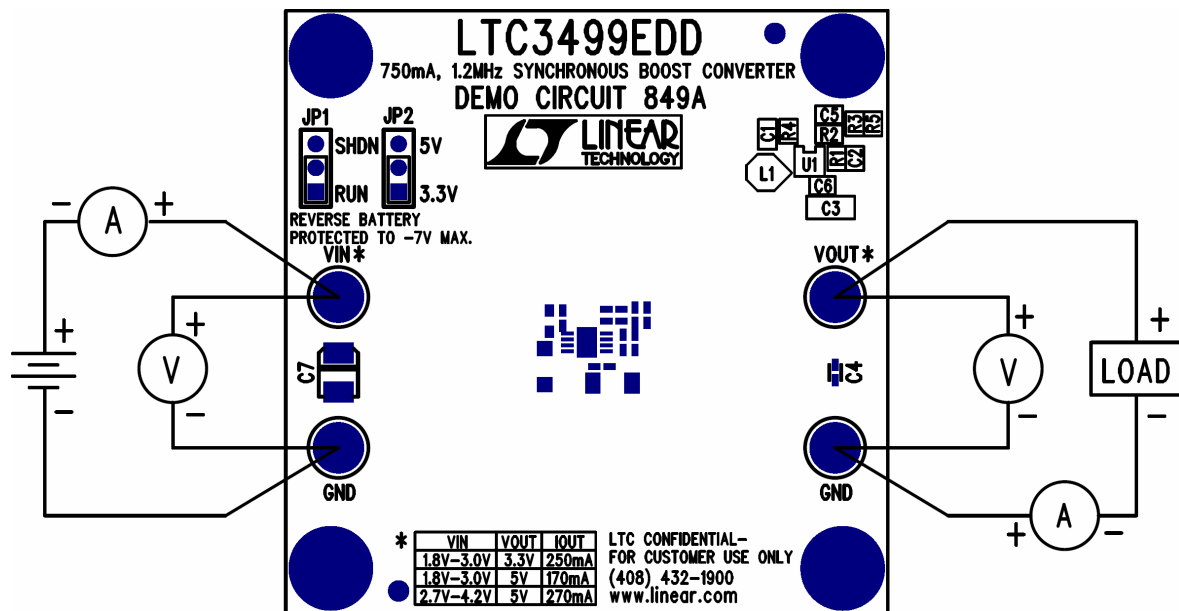

Figure 1. Proper Measurement Equipment Setup

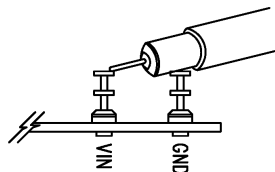
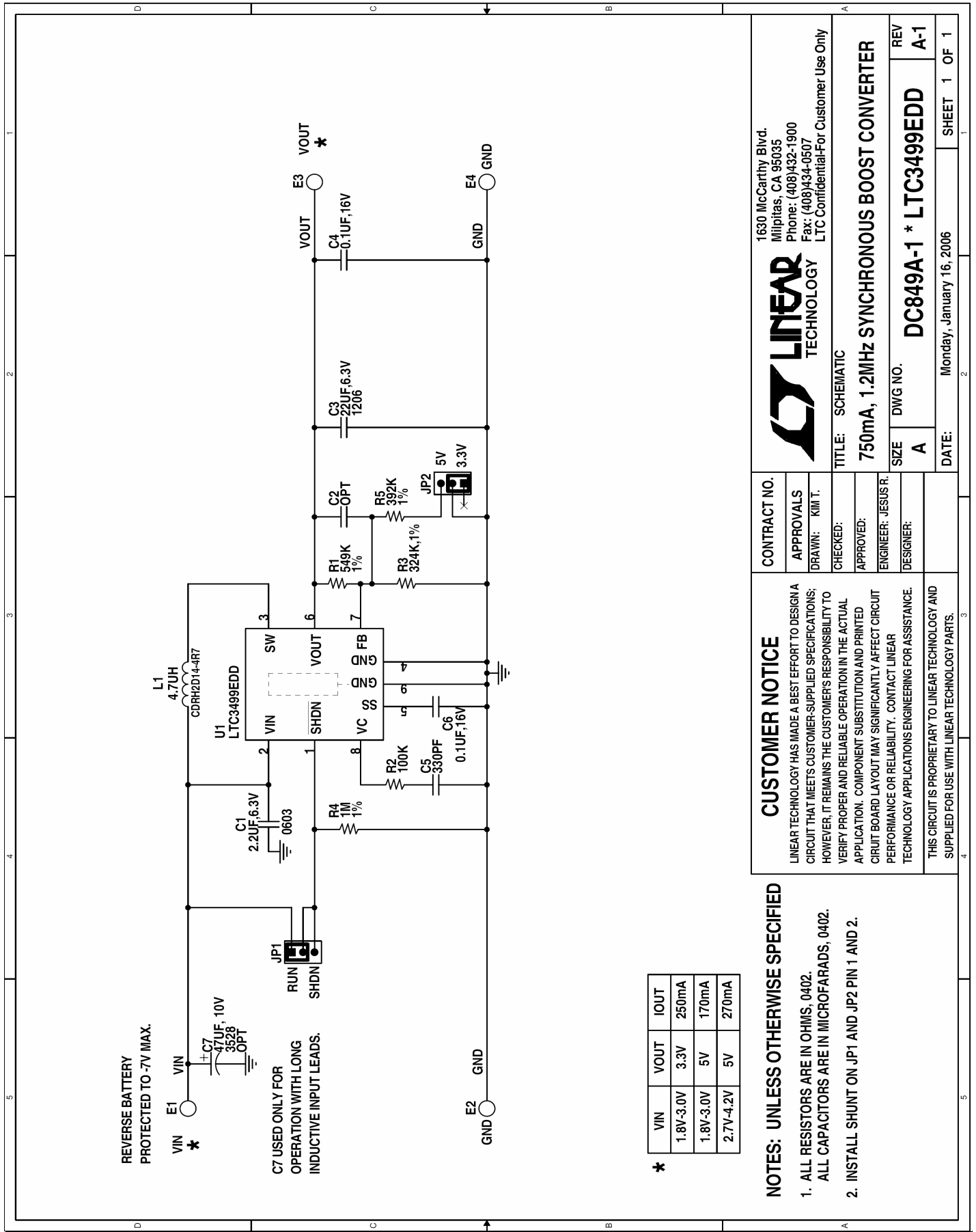

Figure 2. Measuring Input or Output Ripple

QUICK START GUIDE FOR DEMONSTRATION CIRCUIT 849

750mA, 1.2MHz SYNCHRONOUS BOOST CONVERTER



VIN	VOUT	IOUT
1.8V-3.0V	3.3V	250mA
1.8V-3.0V	5V	170mA
2.7V-4.2V	5V	270mA

NOTES: UNLESS OTHERWISE SPECIFIED

1. ALL RESISTORS ARE IN OHMS, 0402.
2. INSTALL SHUNT ON JP1 AND JP2 PIN 1 AND 2.

CUSTOMER NOTICE

LINEAR TECHNOLOGY HAS MADE A BEST EFFORT TO DESIGN A CIRCUIT THAT MEETS CUSTOMER-SUPPLIED SPECIFICATIONS; HOWEVER, IT REMAINS THE CUSTOMER'S RESPONSIBILITY TO VERIFY PROPER AND RELIABLE OPERATION IN THE ACTUAL APPLICATION. COMPONENT SUBSTITUTION AND PRINTED CIRCUIT BOARD LAYOUT MAY SIGNIFICANTLY AFFECT CIRCUIT PERFORMANCE OR RELIABILITY. CONTACT LINEAR TECHNOLOGY APPLICATIONS ENGINEERING FOR ASSISTANCE.

THIS CIRCUIT IS PROPRIETARY TO LINEAR TECHNOLOGY AND SUPPLIED FOR USE WITH LINEAR TECHNOLOGY PARTS.

CONTRACT NO.

APPROVALS
DRAWN: KIM T.
CHECKED:
APPROVED:
ENGINEER: JESUS R.
DESIGNER:

LINEAR TECHNOLOGY
1630 McCarthy Blvd.
Milpitas, CA 95035
Phone: (408)432-1900
Fax: (408)434-0507
LTC Confidential-For Customer Use Only

TITLE: SCHEMATIC

750mA, 1.2MHz SYNCHRONOUS BOOST CONVERTER

SIZE	DWG NO.	REV
A	DC849A-1 * LTC3499EDD	A-1
DATE:	Monday, January 16, 2006	SHEET 1 OF 1

X-ON Electronics

Largest Supplier of Electrical and Electronic Components

Click to view similar products for [Power Management IC Development Tools](#) category:

Click to view products by [Analog Devices](#) manufacturer:

Other Similar products are found below :

[EVAL-ADM1168LQEBZ](#) [EVB-EP5348UI](#) [MIC23451-AAAYFL EV](#) [MIC5281YMME EV](#) [DA9063-EVAL](#) [ADP122-3.3-EVALZ](#) [ADP130-0.8-EVALZ](#) [ADP130-1.2-EVALZ](#) [ADP130-1.5-EVALZ](#) [ADP130-1.8-EVALZ](#) [ADP1714-3.3-EVALZ](#) [ADP1716-2.5-EVALZ](#) [ADP1740-1.5-EVALZ](#) [ADP1752-1.5-EVALZ](#) [ADP1828LC-EVALZ](#) [ADP1870-0.3-EVALZ](#) [ADP1871-0.6-EVALZ](#) [ADP1873-0.6-EVALZ](#) [ADP1874-0.3-EVALZ](#) [ADP1882-1.0-EVALZ](#) [ADP199CB-EVALZ](#) [ADP2102-1.25-EVALZ](#) [ADP2102-1.875EVALZ](#) [ADP2102-1.8-EVALZ](#) [ADP2102-2-EVALZ](#) [ADP2102-3-EVALZ](#) [ADP2102-4-EVALZ](#) [ADP2106-1.8-EVALZ](#) [ADP2147CB-110EVALZ](#) [AS3606-DB](#) [BQ24010EVM](#) [BQ24075TEVM](#) [BQ24155EVM](#) [BQ24157EVM-697](#) [BQ24160EVM-742](#) [BQ24296MEVM-655](#) [BQ25010EVM](#) [BQ3055EVM](#) [NCV891330PD50GEVB](#) [ISLUSBI2CKIT1Z](#) [LM2744EVAL](#) [LM2854EVAL](#) [LM3658SD-AEV/NOPB](#) [LM3658SDEV/NOPB](#) [LM3691TL-1.8EV/NOPB](#) [LM4510SDEV/NOPB](#) [LM5033SD-EVAL](#) [LP38512TS-1.8EV](#) [EVAL-ADM1186-1MBZ](#) [EVAL-ADM1186-2MBZ](#)