

QUICK START GUIDE FOR DEMONSTRATION CIRCUIT 889

900MHZ DIRECT CONVERSION QUADRATURE DEMODULATOR

LT5516

DESCRIPTION

Demonstration circuit 889 is a 900MHz Direct Conversion Quadrature Demodulator featuring the LT5516. The LT[®]5516 is an 800MHz to 1.5GHz direct conversion quadrature demodulator optimized for high linearity receiver applications including PA linearization. It is suitable for communications receivers where an RF signal is directly converted into I and Q baseband signals with bandwidth up to 260MHz. The LT5516 incorporates balanced I and Q mixers, LO buffer amplifiers and a precision, high frequency quadrature generator.

In an RF receiver, the high linearity of the LT5516 provides excellent spur-free dynamic range. This

direct conversion receiver can eliminate the need for intermediate frequency (IF) signal processing, as well as the corresponding requirements for image filtering and IF filtering. Channel filtering can be performed directly at the outputs of the I and Q channels. These outputs can interface directly to channel-select filters (LPFs) or to a baseband amplifier.

Demonstration circuit 889 is designed for operations in the frequency range between 800MHz and 1.5GHz.

Design files for this circuit board are available. Call the LTC factory.

 , LTC and LT are registered trademarks of Linear Technology Corporation

Table 1. Typical Performance Summary (T_A = 25°C)

PARAMETER	CONDITION (f _{RF} = 900MHz, f _{LO} = 901MHz)	VALUE
Supply Voltage		4V to 5.25V
Supply Current	V _{CC} = 5V, EN = High	117mA
Maximum Shutdown Current	V _{CC} = 5V, EN = Low	20μA
Frequency Range		800MHz to 1.5GHz
LO Input Power		-13dBm to -2dBm
Conversion Gain	Voltage Gain, Load Impedance = 1kΩ, P _{RF} = -10dBm, P _{LO} = -5dBm	4.3dB
Noise Figure	P _{LO} = -5dBm, R ₁ = 8.2Ω	11.4dB
Input 3 rd Order Intercept	2-Tone, -10dBm/Tone, Δf = 200kHz, P _{LO} = -5dBm, R ₁ = 3.3Ω	21.5dBm
Input 2 nd Order Intercept	2-Tone, -10dBm/Tone, Δf = 200kHz, P _{LO} = -5dBm, R ₁ = 3.3Ω	51dBm
Input 1dB Compression	P _{LO} = -5dBm, R ₁ = 3.3Ω	9dBm
Baseband Bandwidth		260MHz
I/Q Gain Mismatch	P _{RF} = -5dBm, P _{LO} = -5dBm, output frequency = 1MHz	0.3dB
I/Q Phase Mismatch	P _{RF} = -5dBm, P _{LO} = -5dBm, output frequency = 1MHz	1°
Output Impedance	Differential	120Ω
LO to RF leakage	P _{LO} = -5dBm	-65dBm
RF to LO Isolation	P _{RF} = -10dBm	57dB

APPLICATION NOTE

FREQUENCY RANGE

Demonstration circuit 889 is optimized for the frequency range from 800MHz to 1.5GHz, particularly for the 900MHz Cellular band. This frequency range is limited by the bandwidth of the RF and LO transformers on the PCB. Outside this range, appropriate external RF and LO matching transformers designed for the intended frequency are required to maintain best performance.

CURRENT CONSUMPTION

If lower power consumption is required, the LT5516's supply current can be reduced by increasing the DC

return resistor, R1. However, lowering supply current will degrade linearity.

OUTPUT FILTERING

Proper filtering of unwanted high frequency mixing products at the I- and Q- outputs is important to maintain superior linearity. The most convenient method is to terminate each output with a shunt capacitor to ground. The capacitor value should be optimized depending upon the operating frequency. However, the capacitors may reduce baseband output bandwidth.

QUICK START PROCEDURE

Demonstration circuit 889 is easy to set up to evaluate the performance of the LT5516. Refer to Figure 1 for proper measurement equipment setup and follow the procedure below:

NOTE:

- a. Use high performance signal generators with low harmonic output for 2-tone measurements. Otherwise, low-pass filters at the signal generator outputs should be used to suppress higher-order harmonics.
 - b. High quality combiners that provide 50-ohm termination on all ports and have good port-to-port isolation should be used. Attenuators on the outputs of the signal generators are recommended to further improve source isolation and to reduce reflection into the sources.
1. Connect all test equipment as shown in Figure 1.
 2. Set the DC power supply's current limit to 170mA, and adjust output voltage to 5V.
 3. Connect Vcc to the 5V DC supply, and then connect EN to 5V; the demodulator is enabled (on).
 4. Set Signal Generator #1 to provide a 901MHz, -5dBm, CW signal to the demo board LO input port.
 5. Set the Signal Generators #2 and #3 to provide two -10dBm CW signals to the demo board RF input port—one at 899.9MHz, and the other at 900.1MHz.
 6. Set the Spectrum Analyzer's start frequency to 100kHz and stop frequency to 1400kHz. Perform input 2nd order and 3rd order distortion measurement. Sufficient spectrum analyzer input attenuation should be used to avoid saturating the instrument.
 7. $IIP2 = P1 - P2 + Pin$, $IIP3 = (P1 - P3) / 2 + Pin$. Where P1 is the lowest power level of the two fundamental output tones at either 900kHz or 1100kHz, P2 is the 2nd order product at 200kHz, P3 is the largest 3rd order product at either 700kHz or 1300kHz, and Pin is the input power (in this case, -10dBm). All units are in dBm.
 8. Voltage conversion gain can also be measured. But beware that the gain is reduced by combiner loss plus 6.85dB, because the load impedance to each output pin is 50Ω in this setup. Please refer to the LT5516 data sheet for more detailed explanation

QUICK START GUIDE FOR DEMONSTRATION CIRCUIT 889

900MHZ DIRECT CONVERSION QUADRATURE DEMODULATOR

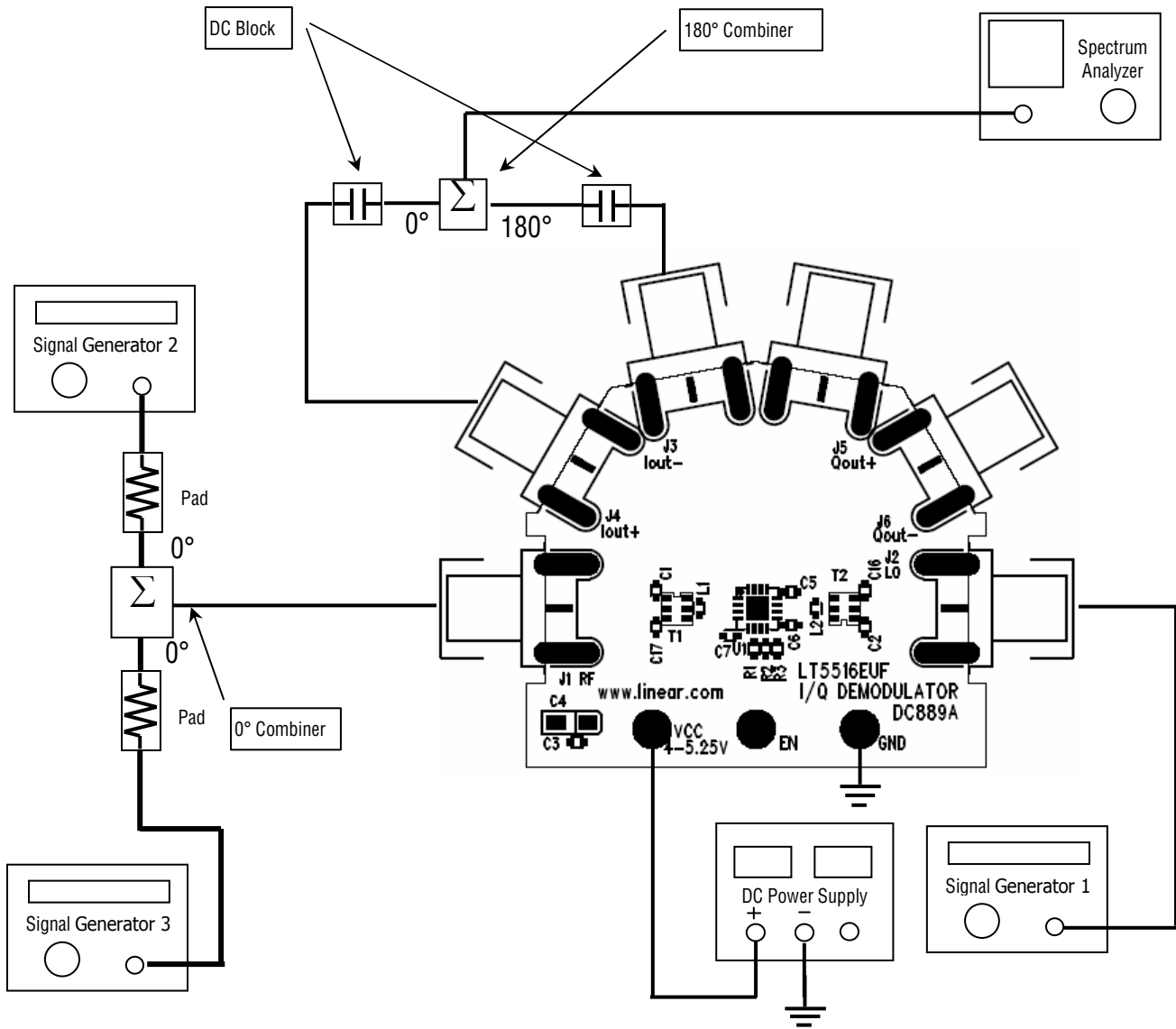
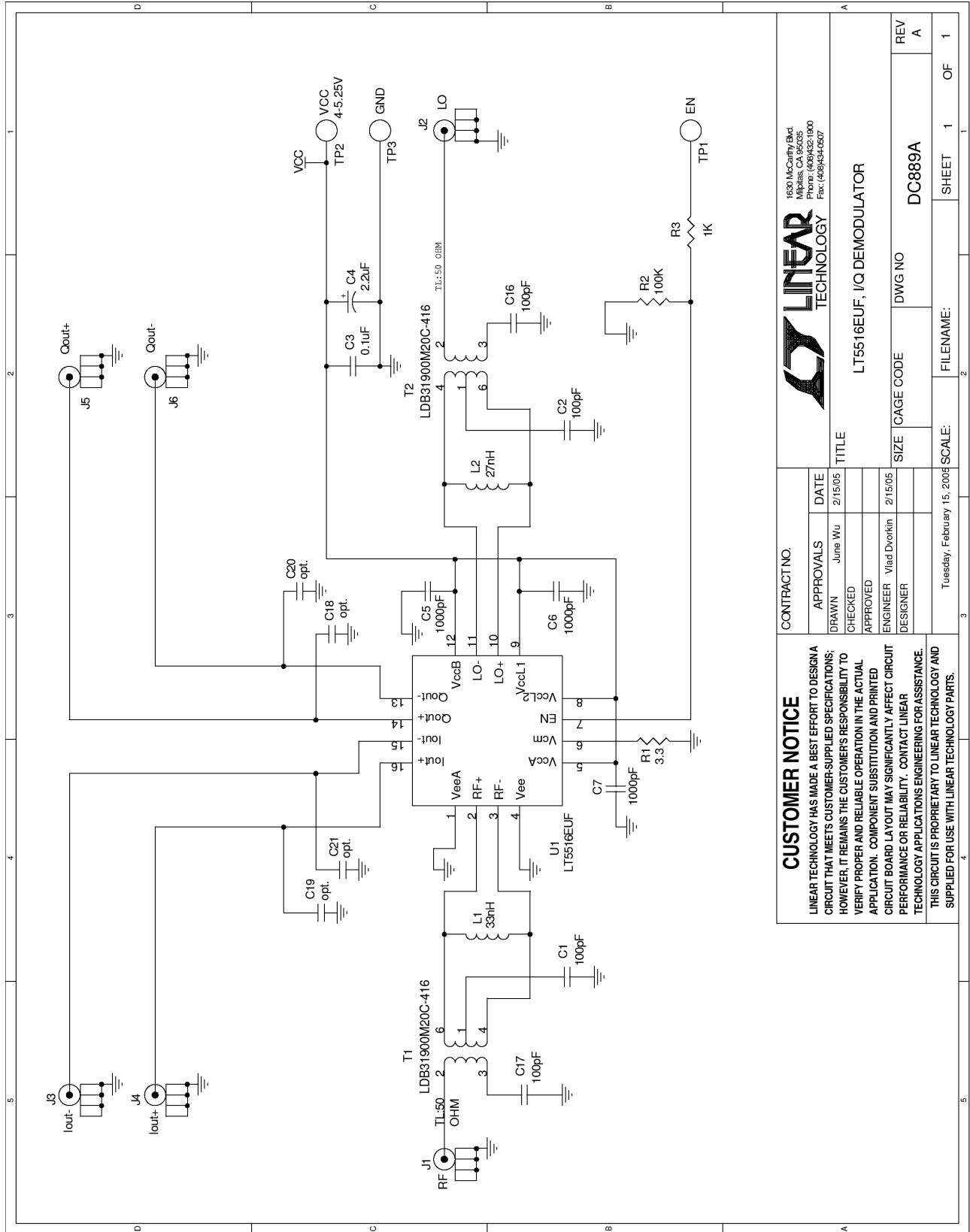

Figure 1. Proper Measurement Equipment Setup

QUICK START GUIDE FOR DEMONSTRATION CIRCUIT 889

900MHZ DIRECT CONVERSION QUADRATURE DEMODULATOR



		1630 McCarthy Blvd. Milpitas, CA 95035 Phone: (408)432-1900 Fax: (408)432-0607	
		CONTRACT NO.	
CUSTOMER NOTICE LINEAR TECHNOLOGY HAS MADE A BEST EFFORT TO DESIGN A CIRCUIT THAT MEETS CUSTOMER-SUPPLIED SPECIFICATIONS; HOWEVER, IT REMAINS THE CUSTOMER'S RESPONSIBILITY TO VERIFY PROPER AND RELIABLE OPERATION IN THE ACTUAL APPLICATION. COMPONENT SUBSTITUTION AND PRINTED CIRCUIT BOARD LAYOUT MAY SIGNIFICANTLY AFFECT CIRCUIT PERFORMANCE OR RELIABILITY. CONTACT LINEAR TECHNOLOGY APPLICATIONS ENGINEERING FOR ASSISTANCE. THIS CIRCUIT IS PROPRIETARY TO LINEAR TECHNOLOGY AND SUPPLIED FOR USE WITH LINEAR TECHNOLOGY PARTS.		TITLE LT5516EUF, I/Q DEMODULATOR	
APPROVALS DRAWN June Wu CHECKED APPROVED ENGINEER Vlado Dvorzkin DESIGNER	DATE 2/15/05	SIZE CAGE CODE DWG NO DC889A	REV A
FILENAME:		SCALE:	SHEET 1 OF 1

X-ON Electronics

Largest Supplier of Electrical and Electronic Components

Click to view similar products for [Sub-GHz Development Tools](#) category:

Click to view products by [Analog Devices](#) manufacturer:

Other Similar products are found below :

[EVAL-ADF7021DBJZ](#) [EVAL-ADF7021-NDBZ2](#) [EVAL-ADF7021-VDB3Z](#) [EVAL-ADF7023DB3Z](#) [MICRF219A-433 EV](#) [MICRF220-433 EV](#) [AD6679-500EBZ](#) [EVAL-ADF7901EBZ](#) [EVAL-ADF790XEBZ](#) [110976-HMC453QS16G](#) [STEVAL-IKR002V7D](#) [MAX2602EVKIT+](#) [MAX1472EVKIT-315](#) [MAX1479EVKIT-315](#) [STEVAL-IKR002V3D](#) [MAX7042EVKIT-315+](#) [MAX2902EVKIT#](#) [MAX9947EVKIT+](#) [MAX1470EVKIT-315](#) [SKY66188-11-EK1](#) [SKY66013-11-EVB](#) [EVAL-ADF7023DB5Z](#) [DRF1200/CLASS-E](#) [1096](#) [1097](#) [1098](#) [MDEV-900-PRO](#) [DVK-SFUS-1-GEVK](#) [DVK-SFUS-API-1-GEVK](#) [US-SIGFOX-GEVB](#) [STEVAL-IKR002V2D](#) [107755-HMC454ST89](#) [DM182017-2](#) [110961-HMC453ST89](#) [DM182017-1](#) [3179](#) [DC689A](#) [DC1513B-AB](#) [3229](#) [3230](#) [3231](#) [3232](#) [DC1250A-AA](#) [DC1513B-AC](#) [DC1513B-AD](#) [DC1513B-AA](#) [TEL0075](#) [RFX1010-EK1](#) [131903-HMC921LP4E](#) [EU-SIGFOX-GEVB](#)