

DESCRIPTION

Demonstration circuit 894A-A is a 36V-72Vin, synchronous flyback converter featuring the LT3825. This circuit was designed specifically to attain a high current, low ripple, synchronously rectified flyback to efficiently power 3.3V loads at up to 12A from a typical telecom input voltage range. This circuit features synchronous rectifier drive outputs, output voltage

regulation without the need of an optocoupler, self-starting architecture and input undervoltage lockout.

Design files for this circuit board are available. Call the LTC factory.

 , LTC and LT are registered trademarks of Linear Technology Corporation.

Table 1. Performance Summary (T_A = 25°C)

PARAMETER	CONDITION	VALUE
Minimum Input Voltage		36V
Maximum Input Voltage		72V
Output Voltage V _{OUT}	V _{IN} = 36V to 72V, I _{OUT} = 0A to 12A	3.3V
Maximum Output Current		12A
Typical Output Ripple V _{OUT}	V _{IN} = 48V, I _{OUT} = 12A	< 20mV _{P-P}
Output Regulation	Over All Input Voltages and Output Currents	±1.25%
Load Transient Response	Peak Deviation with Load Step of 9A to 12A (10A/us)	±140mV (< ±4.5%)
	Settling Time	100us
Nominal Switching Frequency		200kHz
Efficiency	V _{IN} = 48V, I _{OUT} = 12A	89% Typical

OPERATING PRINCIPLES

The LT3825 controller exhibits a self-starting capability. When an input voltage is applied, a trickle charge resistor, R8, charges C10 (See Figure 12) to power V_{CC}. Then, the IC begins a controlled soft-start of the output voltage. As this voltage begins to rise, V_{CC} power is quickly taken over by T1, D2, and R7. When the soft-start period is over, the LT3825 then regulates output voltage by observing the pulses across the auxiliary winding of T1 during the flyback time. The Primary Gate drive (PG) and Synchronous Gate drive (SG) is then Pulse Width Modulated (PWM) in

order to keep the output voltage constant. The synchronous gate drive signal is transmitted to the secondary via the small signal transformer, T2. The output of T2 then drives a discreet gate drive buffer, R26, Q12, and Q13 in order to achieve fast gate transition times, hence a higher efficiency.

The two-stage input filter, C25, L1, and C30 and output filter, C1, C2, C5, L2, and C29 are the reasons that this flyback has exceptionally low conducted emissions.

QUICK START PROCEDURE

Demonstration circuit 894A-A is easy to set up to evaluate the performance of the LT3825. Refer to Figure 1 for proper measurement equipment setup and follow the procedure below:

NOTE: When measuring the input or output voltage ripple, care must be taken to avoid a long ground lead on the oscilloscope probe. Measure the output (or input) voltage ripple by touching the probe tip and probe ground directly across the +Vout and -Vout (or +VIN and -VIN) terminals. See Figure 2 for proper scope probe technique.

1. Set an input power supply that is capable of 36V to 72V at a current of at least 2A to a voltage of 36V. Then, turn off the supply.
2. With power off, connect the supply to the input terminals +VIN and -VIN.
 - a. Input voltages lower than 36V can keep the converter from turning on due to the undervoltage lockout feature of the LT3825.
 - b. If efficiency measurements are desired, an ammeter capable of measuring 2A_{dc} can be put in series with the input supply in order to measure the DC894A-A's input current.
 - c. A voltmeter with a capability of measuring at least 72V can be placed across the input terminals in order to get an accurate input voltage measurement.
3. Turn on the power at the input.

NOTE: Make sure that the input voltage never exceeds 72V.
4. Check for the proper output voltage of 3.3V. Turn off the power at the input.
5. Once the proper output voltages are established, connect a variable load capable of sinking 12A at 3.3V to the output terminals +Vout and -Vout. Set the current for 0A.
 - a. If efficiency measurements are desired, an ammeter or a resistor current shunt that is capable of handling at least 12A_{dc} can be put in series with the output load in order to measure the DC894A-A's output current.
 - b. A voltmeter with a capability of measuring at least 3.3V can be placed across the output terminals in order to get an accurate output voltage measurement.
6. Turn on the power at the input.

NOTE: If there is no output, temporarily disconnect the load to make sure that the load is not set too high.
7. Once the proper output voltage is established, adjust the load within the operating range and observe the output voltage regulation, ripple voltage, efficiency and other desired parameters.

QUICK START GUIDE FOR DEMONSTRATION CIRCUIT 894A-A

36V-72VIN, FORWARD CONVERTER

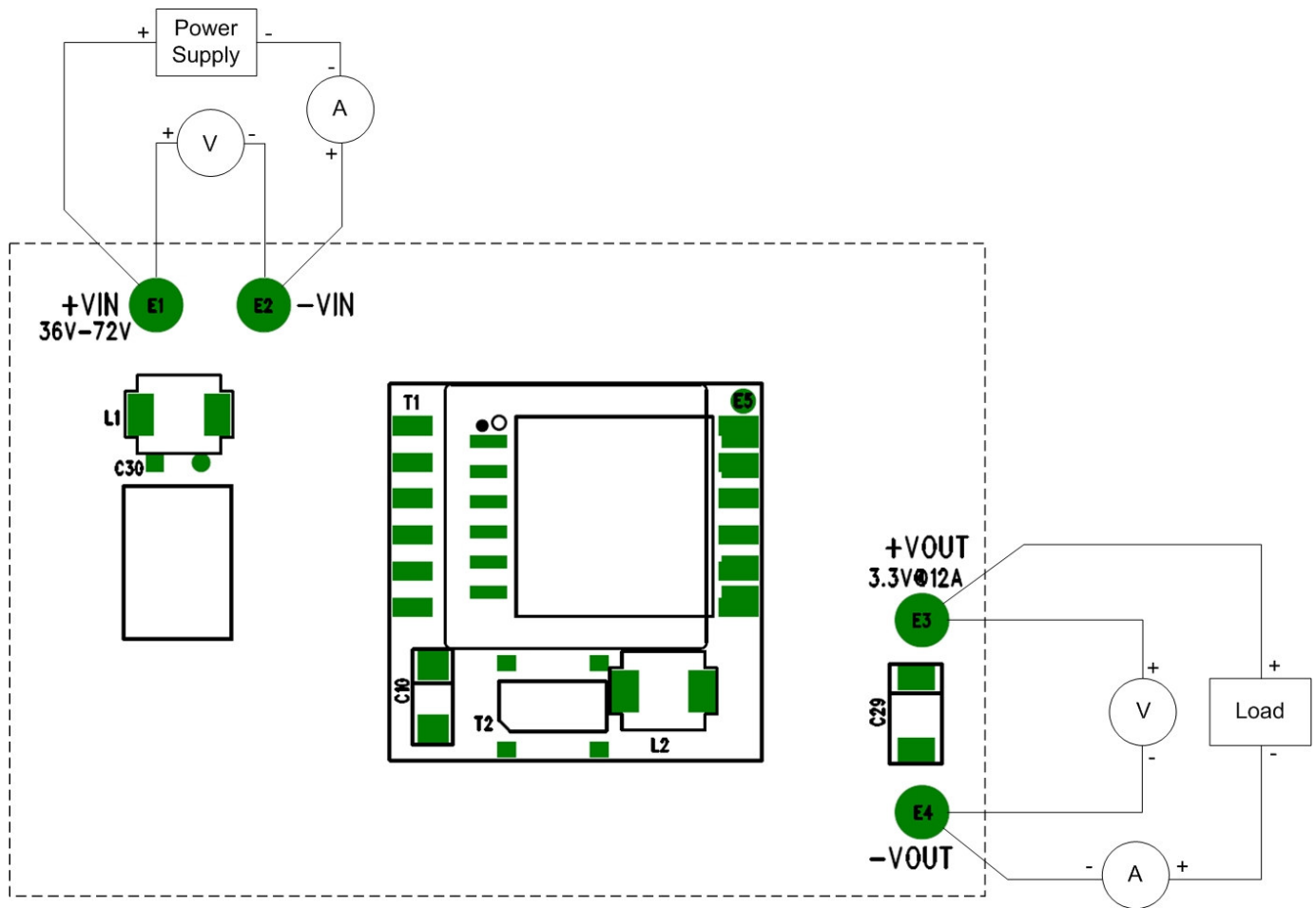

Figure 1. Proper Measurement Equipment Setup

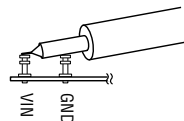

Figure 2. Measuring Input or Output Ripple

MEASURED DATA

Figures 3 through 10 are measured data for a typical DC894A-A. Figures 11 through 13 are schematics and bill of materials.

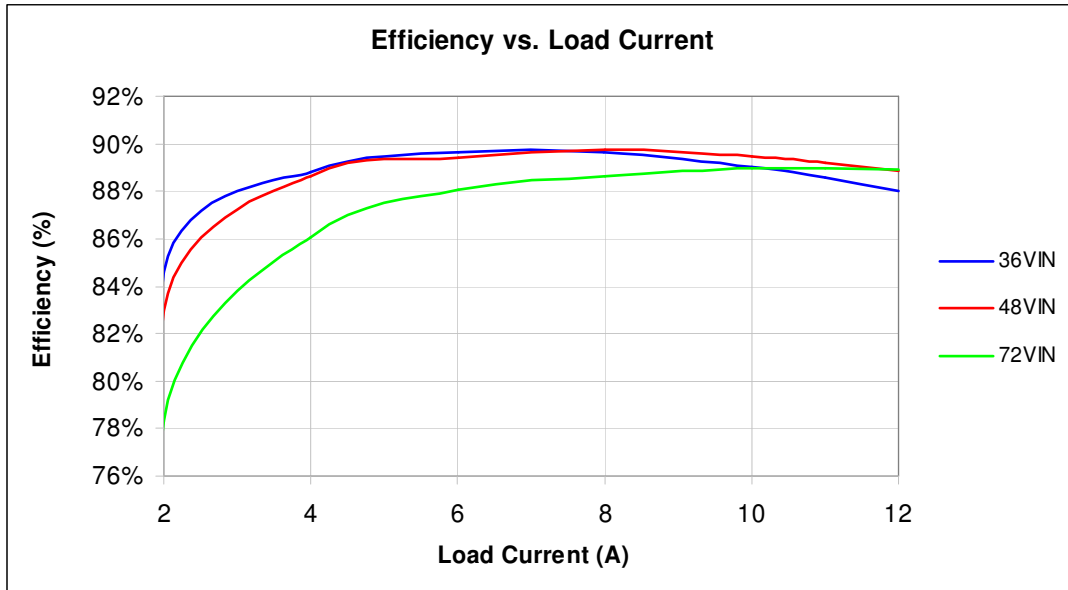

Figure 3. Efficiency (no airflow)

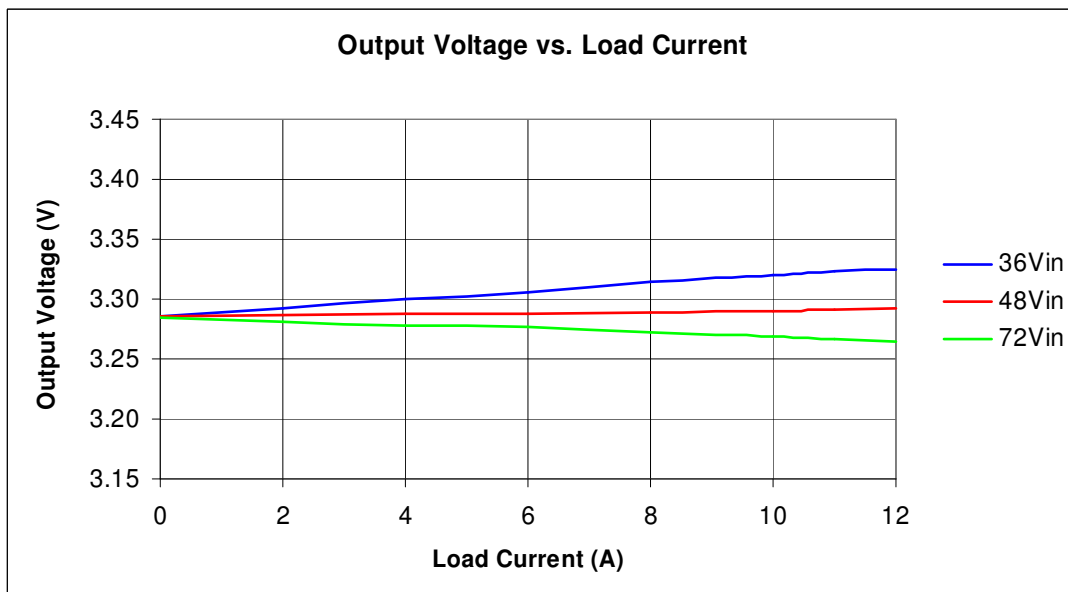

Figure 4. Regulation (400LFM)

QUICK START GUIDE FOR DEMONSTRATION CIRCUIT 894A-A

36V-72VIN, FORWARD CONVERTER

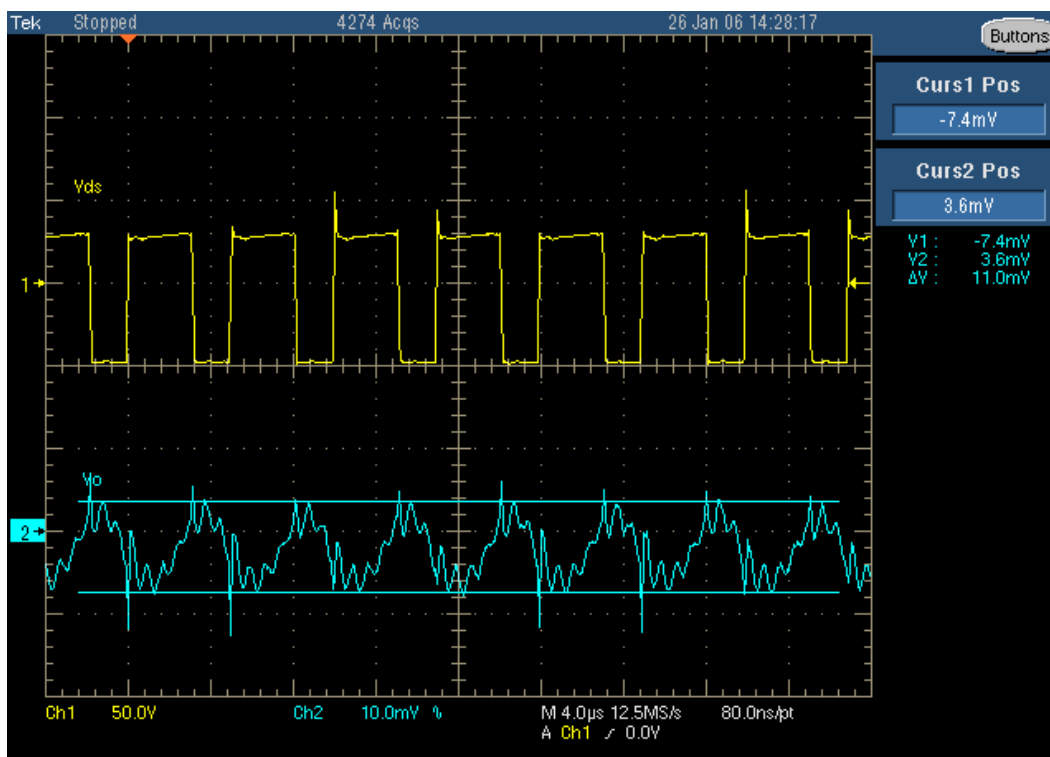

Figure 5. Output Voltage Ripple (48Vin 12A)

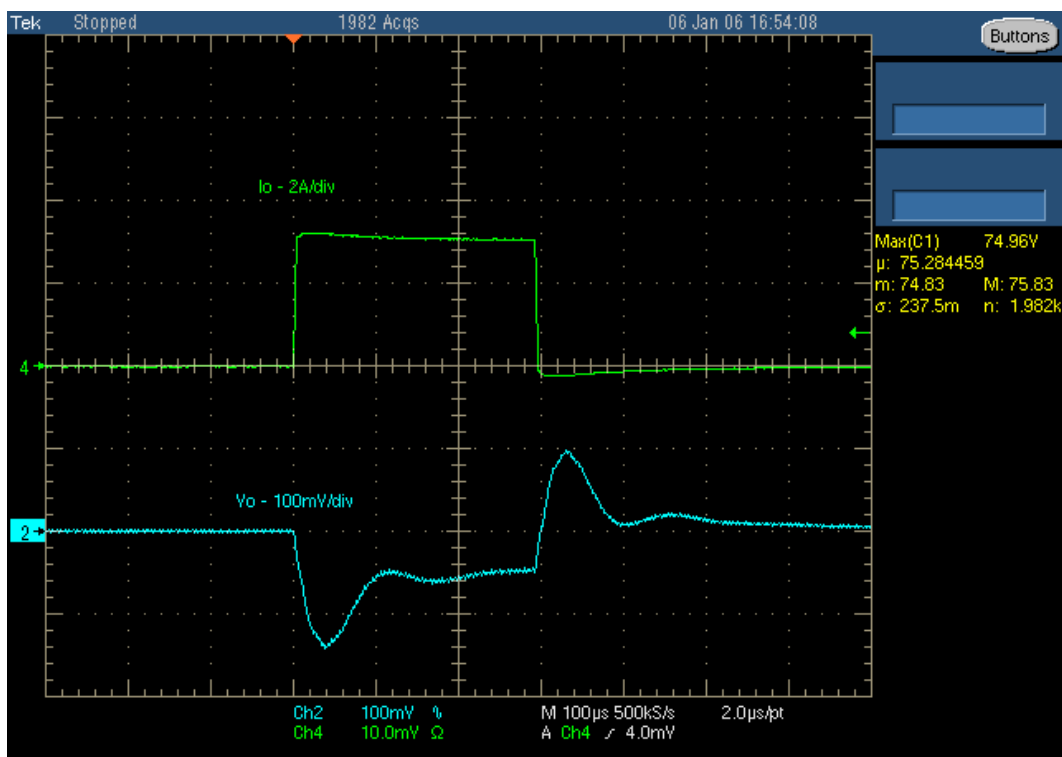

Figure 6. Load Transient Response (10A/us)

QUICK START GUIDE FOR DEMONSTRATION CIRCUIT 894A-A 36V-72VIN, FORWARD CONVERTER

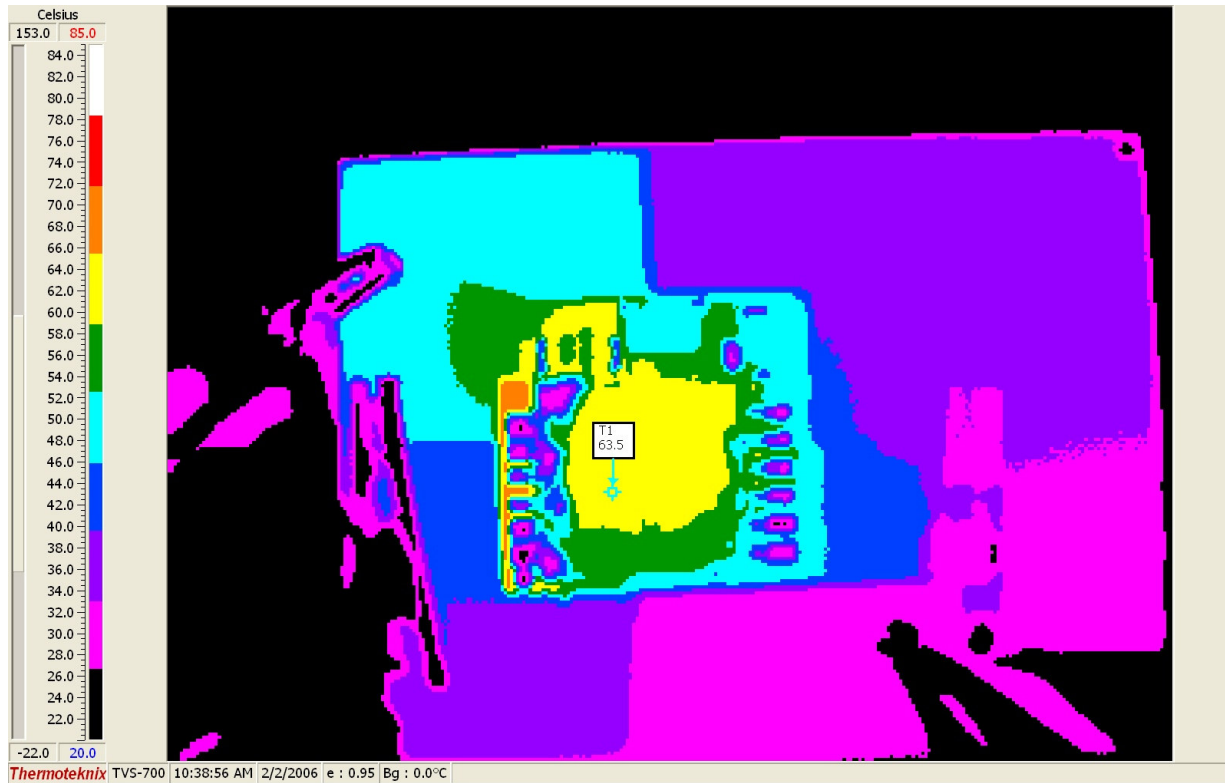

Figure 7. Temp Data (48Vin, 12A, 100LFM airflow – front)



Figure 8. Temp Data (48Vin, 12A, 100LFM airflow – back)

QUICK START GUIDE FOR DEMONSTRATION CIRCUIT 894A-A 36V-72VIN, FORWARD CONVERTER

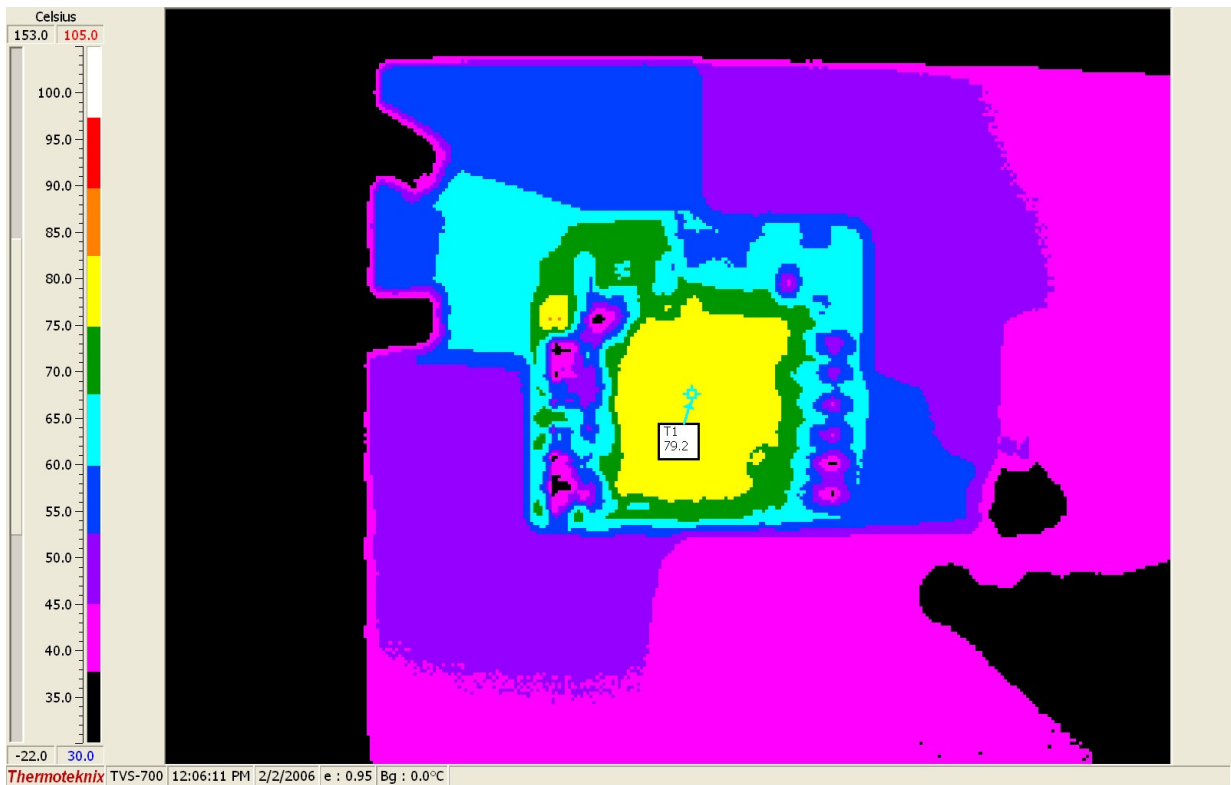

Figure 9. Temp Data (48Vin, 12A, no airflow – front)

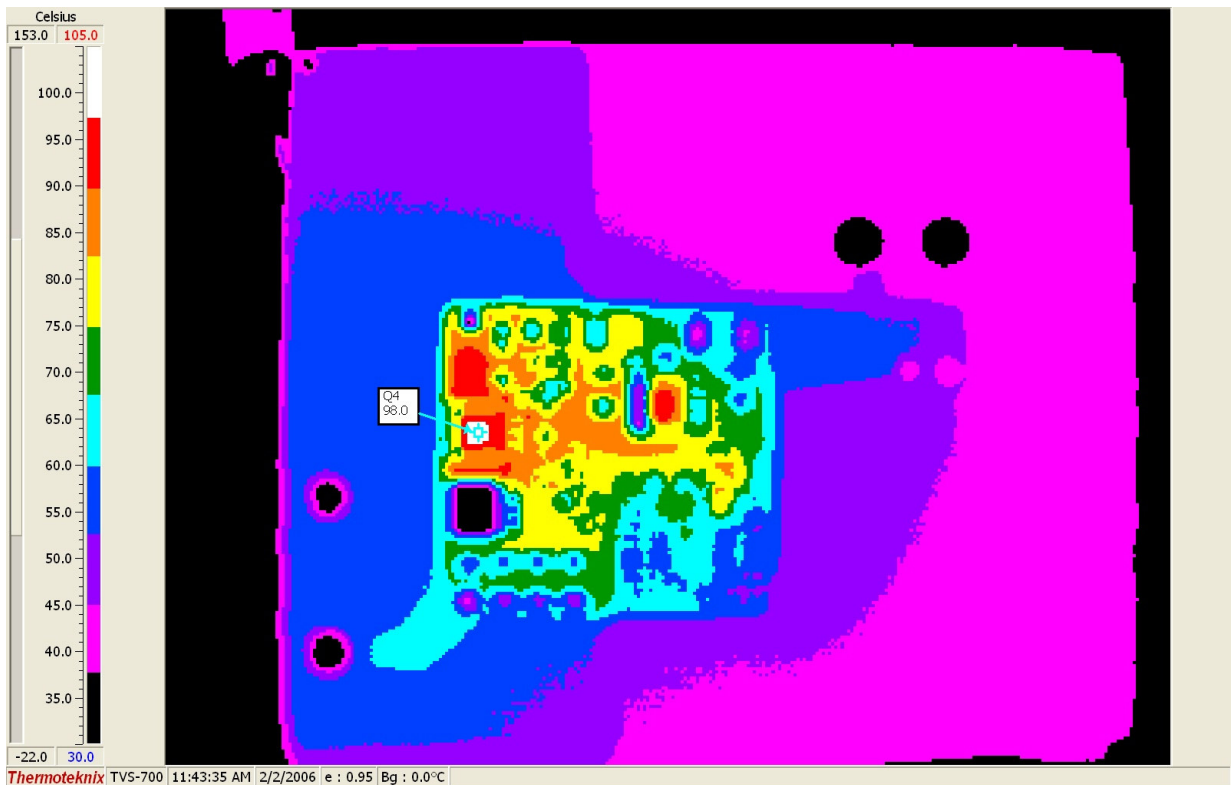

Figure 10. Temp Data (48Vin, 12A, no airflow – back)

QUICK START GUIDE FOR DEMONSTRATION CIRCUIT 894A-A

36V-72VIN, FORWARD CONVERTER

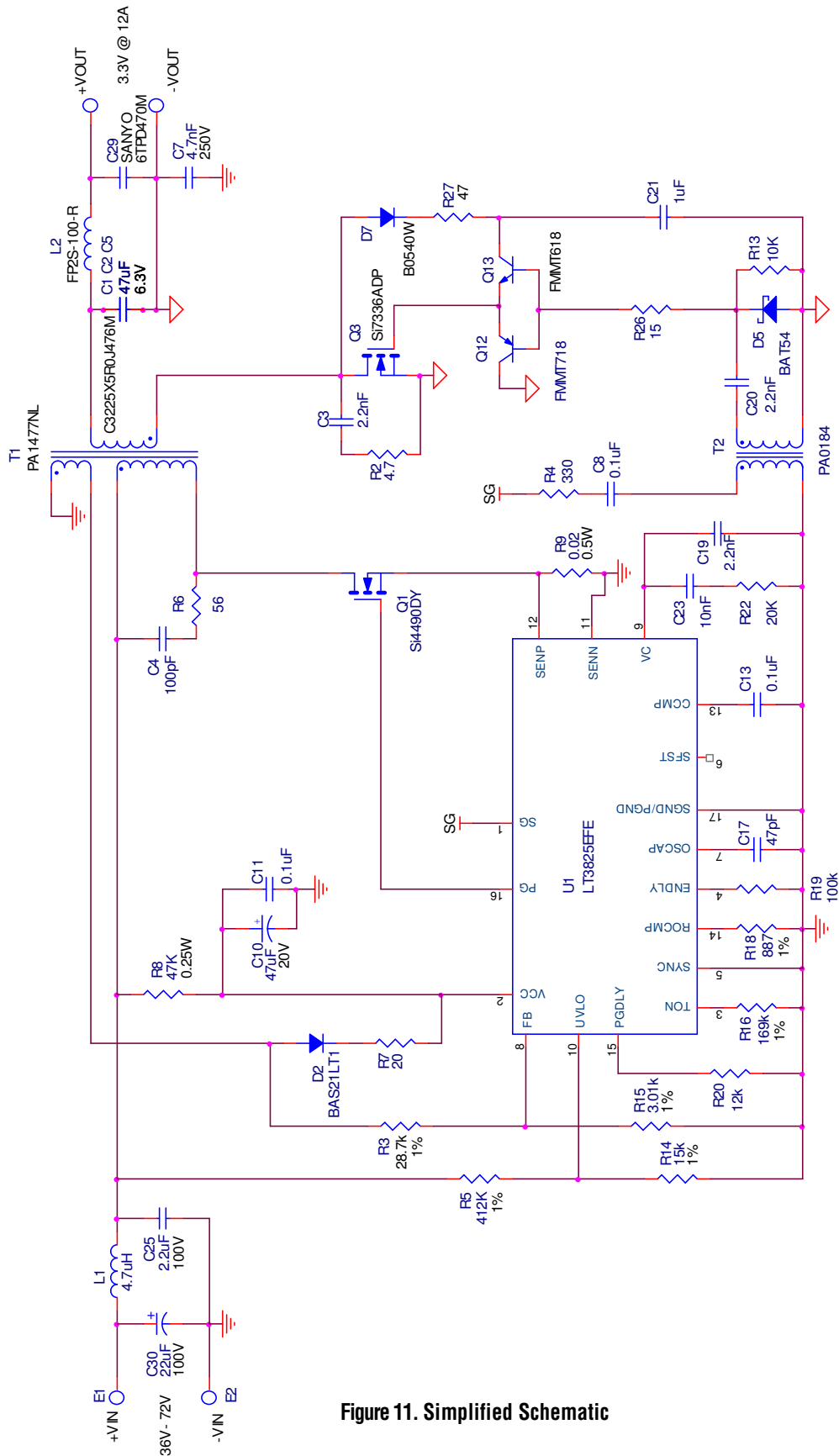

Figure 11. Simplified Schematic

QUICK START GUIDE FOR DEMONSTRATION CIRCUIT 894A-A

36V-72VIN, FORWARD CONVERTER

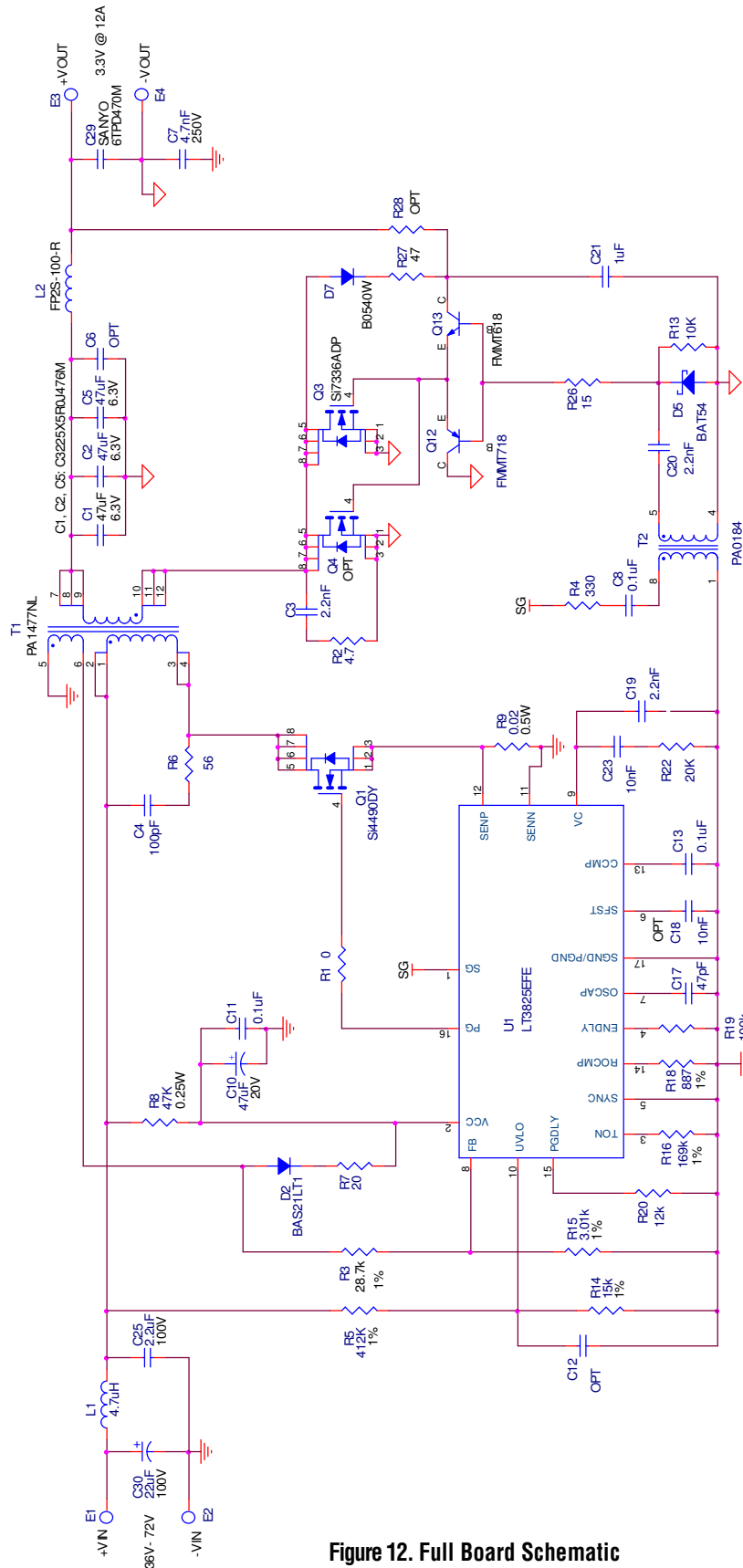

Figure 12. Full Board Schematic

QUICK START GUIDE FOR DEMONSTRATION CIRCUIT 894A-A

36V-72VIN, FORWARD CONVERTER

<i>Item</i>	<i>Qty</i>	<i>Ref-Des</i>	<i>Description</i>	<i>Manufacturer's Part Number</i>
REQUIRED CIRCUIT COMPONENTS¹				
1	1	C3	CAP, 1206 2.2nF 20% 100V X7R	AVX 12061C222MAT
2	1	C4	CAP, 1206 100pF 10% 630V COG	TDK C3216COG2J101K
3	3	C5,C2,C1	CAP, 1210 47uF 20% 6.3V X5R	TDK C3225X5R0J476MT
5	1	C7	CAP, 4.7nF 10% 250V X7R	MURATA GA343DR7GD472KW01L
6	3	C8,C11,C13	CAP, 0603 0.1uF 10% 50V X7R	TDK C1608X7R1H104K
7	1	C10	CAP, 6032 47uF 20% 20V TANT	AVX TAJC476M020R
9	1	C17	CAP, 0603 47pF 10% 25V NPO	AVX 06033A470KAT2A
11	2	C19,C20	CAP, 0603 2.2nF 5% 50V X7R	AVX 06035C222JAT
12	1	C21	CAP, 1206 1uF 20% 25V X7R	AVX 12063C105MAT2A
13	1	C23	CAP, 0603 10nF 10% 25V X7R	AVX 06033C103KAT
14	1	C25	CAP, 1812 2.2uF 10% 100V X7R	TDK C4532X7R2A225K
15	1	C29	CAP, 7343 470uF 20% 6.3V POSCAP	SANYO 6TPD470M
17	1	D2	DIODE, BAS21-7	DIODES INC. BAS21-7-F
18	1	D5	DIODE, SCHOTTKY	DIODES INC. BAT54-7
19	1	D7	DIODE, SCHOTTKY	DIODES INC. B0540W-7-F
22	1	L2	IND, 0.1uH	COILTRONICS FP2S-100-R
23	1	Q1	XSTR, MOSFET N-CHANNEL	VISHAY SILICONIX Si4490DY
24	1	Q3	XSTR, MOSFET N-CHANNEL	VISHAY SILICONIX Si7336ADP
26	1	Q12	XSTR, PNP	ZETEX FMMT718TA
27	1	Q13	XSTR, NPN	ZETEX FMMT618TA
29	1	R2	RES, 1206 4.7 OHMS 5% 1/4W	AAC CR18-4R7JM
30	1	R3	RES, 0603 28.7K OHMS 1% 1/10W	VISHAY CRCW06032872FRT6
31	1	R4	RES, 0603 330 OHMS 5% 1/10W	AAC CR16-331JM
32	1	R5	RES, 0603 412K OHMS 1% 1/8W	AAC CR16-4123FM
33	1	R6	RES, 1206 56 OHMS 5% 1/4W	AAC CR18-560JM
34	1	R7	RES, 0805 20 OHMS 5% 1/8W	AAC CR10-200JM
35	1	R8	RES, 1206 47K OHMS 5% 1/4W	AAC CR18-473JM
36	1	R9	RES, 1206 0.02 OHMS 1% 0.5W	IRC LRC-LRF1206-01-R020-F
37	1	R13	RES, 0603 10K OHMS 5% 1/10W	AAC CR16-103JM
38	1	R22	RES, 0603 20K OHMS 5% 1/10W	AAC CR16-203JM
39	1	R14	RES, 0603 15K OHMS 1% 1/10W	AAC CR16-1502FM
40	1	R15	RES, 0603 3.01K OHMS 1% 1/10W	AAC CR16-3011FM
41	1	R16	RES, 0603 169K OHMS 1% 1/10W	AAC CR16-1693FM
42	1	R18	RES, 0603 909 OHMS 1% 1/10W	AAC CR16-9090FM
43	1	R19	RES, 0603 100K OHMS 5% 1/10W	AAC CR16-104JM
44	1	R20	RES, 0603 12K OHMS 5% 1/10W	AAC CR16-123JM
45	1	R26	RES, 0603 15 OHMS 5% 1/10W	AAC CR16-150JM
46	1	R27	RES, 0805 47 OHMS 5% 1/8W	VISHAY CRCW0805470JRT6
48	1	T1	XFMR, PA1477NL	PULSE PA1477NL
49	1	T2	XFMR, 1.4mH MIN, 50KHz	PULSE PA0184
50	1	U1	IC, LT3825EFE	LINEAR TECH LT3825EFE
ADDITIONAL DEMO BOARD CIRCUIT COMPONENTS²				
4	0	C6	CAP, 1210 47uF 20% 6.3V X5R OPTION	TDK C3225X5R0J476MT OPTION
8	0	C12	CAP, 0603 470pF 10% 25V NPO OPTION	AVX 06033A471KAT2A OPTION
10	0	C18	CAP, 0603 10nF 10% 25V X7R OPTION	AVX 06033C103KAT OPTION
16	1	C30	CAP, 22uF 100V	SANYO 100ME22AXTS

QUICK START GUIDE FOR DEMONSTRATION CIRCUIT 894A-A

36V-72VIN, FORWARD CONVERTER

20	4	E1,E2,E3,E4	TURRET	MILL-MAX 2501-2
21	1	L1	IND, 4.7uH	VISHAY IHPL2525CZER4R7M01
25	0	Q4	XSTR, MOSFET N-CHANNEL OPTION	VISHAY SILICONIX Si7336ADP OPTION
28	1	R1	RES, 0603 0 OHM JUMPER	VISHAY CRCW0603000ZRT6
47	0	R28	RES, 0805 OPTION	OPTION

Notes:

1. Required Circuit Components are those parts that are required to implement the circuit function
2. Additional Demo Board Circuit Components are those parts that provide added functionality for the demo board but are or may not be required in the actual circuit.

Figure 13. Bill of Materials

X-ON Electronics

Largest Supplier of Electrical and Electronic Components

Click to view similar products for [Power Management IC Development Tools](#) category:

Click to view products by [Analog Devices](#) manufacturer:

Other Similar products are found below :

[EVAL-ADM1168LQEBZ](#) [EVB-EP5348UI](#) [MIC23451-AAAYFL EV](#) [MIC5281YMME EV](#) [DA9063-EVAL](#) [ADP122-3.3-EVALZ](#) [ADP130-0.8-EVALZ](#) [ADP130-1.2-EVALZ](#) [ADP130-1.5-EVALZ](#) [ADP130-1.8-EVALZ](#) [ADP1714-3.3-EVALZ](#) [ADP1716-2.5-EVALZ](#) [ADP1740-1.5-EVALZ](#) [ADP1752-1.5-EVALZ](#) [ADP1828LC-EVALZ](#) [ADP1870-0.3-EVALZ](#) [ADP1871-0.6-EVALZ](#) [ADP1873-0.6-EVALZ](#) [ADP1874-0.3-EVALZ](#) [ADP1882-1.0-EVALZ](#) [ADP199CB-EVALZ](#) [ADP2102-1.25-EVALZ](#) [ADP2102-1.875EVALZ](#) [ADP2102-1.8-EVALZ](#) [ADP2102-2-EVALZ](#) [ADP2102-3-EVALZ](#) [ADP2102-4-EVALZ](#) [ADP2106-1.8-EVALZ](#) [ADP2147CB-110EVALZ](#) [AS3606-DB](#) [BQ24010EVM](#) [BQ24075TEVM](#) [BQ24155EVM](#) [BQ24157EVM-697](#) [BQ24160EVM-742](#) [BQ24296MEVM-655](#) [BQ25010EVM](#) [BQ3055EVM](#) [NCV891330PD50GEVB](#) [ISLUSBI2CKIT1Z](#) [LM2744EVAL](#) [LM2854EVAL](#) [LM3658SD-AEV/NOPB](#) [LM3658SDEV/NOPB](#) [LM3691TL-1.8EV/NOPB](#) [LM4510SDEV/NOPB](#) [LM5033SD-EVAL](#) [LP38512TS-1.8EV](#) [EVAL-ADM1186-1MBZ](#) [EVAL-ADM1186-2MBZ](#)