

DESCRIPTION

Demonstration circuit 894C-B is a 36V-72Vin, synchronous flyback converter featuring the LT3825. This circuit was designed specifically to attain a high current, low ripple, synchronously rectified flyback to efficiently power 5.0V loads at up to 8A from a typical telecom input voltage range. This circuit features synchronous rectifier drive outputs, output voltage reg-

ulation without the need of an optocoupler, self-starting architecture and input undervoltage lockout.

Design files for this circuit board are available. Call the LTC factory.

LT, LTC and LT are registered trademarks of Linear Technology Corporation.

Table 1. Performance Summary (T_A = 25°C)

PARAMETER	CONDITION	VALUE
Minimum Input Voltage		36V
Maximum Input Voltage		72V
Output Voltage V _{OUT}	V _{IN} = 36V to 72V, I _{OUT} = 0A to 8A	5.0V
Maximum Output Current		8A
Output Ripple V _{OUT}	V _{IN} = 48V, I _{OUT} = 8A	< 20mV _{P-P} (typical)
Output Regulation	Over All Input Voltages and Output Currents	±1.0% (typical)
Load Transient Response	Peak Deviation with Load Step of 6A to 8A (10A/us)	±100mV (< ± 2%)
	Settling Time	100us
Nominal Switching Frequency		200kHz
Efficiency	V _{IN} = 48V, I _{OUT} = 8A	92% (typical)

OPERATING PRINCIPLES

The LT3825 controller exhibits a self-starting capability. When an input voltage is applied, a trickle charge resistor, R8, charges C10 (See Figure 9) to power V_{CC}. Then, the IC begins a controlled soft-start of the output voltage. As this voltage begins to rise, V_{CC} power is quickly taken over by T1, D2, and R7. When the soft-start period is over, the LT3825 then regulates output voltage by observing the pulses across the auxiliary winding of T1 during the flyback time. The Primary Gate drive (PG) and Synchronous Gate (SG) drive is then Pulse Width

Modulated (PWM) in order to keep the output voltage constant. The synchronous gate drive signal is transmitted to the secondary via the small signal transformer, T2. The output of T2 then drives a discreet gate drive buffer, R26, Q12, and Q13 in order to achieve fast gate transition times, hence a higher efficiency.

The two-stage input filter, C25, L1, and C30 and output filter, C1, C2, C5, L2, and C29 are the reasons that this flyback has exceptionally low conducted emissions.

QUICK START PROCEDURE

Demonstration circuit 894C-B is easy to set up to evaluate the performance of the LT3825. Refer to Figure 1 for proper measurement equipment setup and follow the procedure below:

NOTE: When measuring the input or output voltage ripple, care must be taken to avoid a long ground lead on the oscilloscope probe. Measure the output (or input) voltage ripple by touching the probe tip and probe ground directly across the +Vout and –Vout (or +Vin and –Vin) terminals. See Figure 2 for proper scope probe technique.

1. Set an input power supply that is capable of 36V to 72V at a current of at least 2A to a voltage of 36V. Then, turn off the supply.
2. With power off, connect the supply to the input terminals +Vin and –Vin.
 - a. Input voltages lower than 36V can keep the converter from turning on due to the undervoltage lockout feature of the LT3825.
 - b. If efficiency measurements are desired, an ammeter capable of measuring 2A_{dc} can be put in series with the input supply in order to measure the DC894C-B's input current.
 - c. A voltmeter with a capability of measuring at least 72V can be placed across the input terminals in order to get an accurate input voltage measurement.
3. Turn on the power at the input.

NOTE: Make sure that the input voltage never exceeds 72V.
4. Check for the proper output voltage of 5.0V
5. Turn off the power at the input.
6. Once the proper output voltages are established, connect a variable load capable of sinking 8A at 5.0V to the output terminals +Vout and –Vout. Set the current for 0A.
 - a. If efficiency measurements are desired, an ammeter or a resistor current shunt that is capable of handling at least 8A_{dc} can be put in series with the output load in order to measure the DC894C-B's output current.
 - b. A voltmeter with a capability of measuring at least 5.0V can be placed across the output terminals in order to get an accurate output voltage measurement.
7. Turn on the power at the input.

NOTE: If there is no output, temporarily disconnect the load to make sure that the load is not set too high.
8. Once the proper output voltage is established, adjust the load within the operating range and observe the output voltage regulation, ripple voltage, efficiency and other desired parameters.

QUICK START GUIDE FOR DEMONSTRATION CIRCUIT 894C-B

36V-72VIN, SYNCHRONOUS FLYBACK

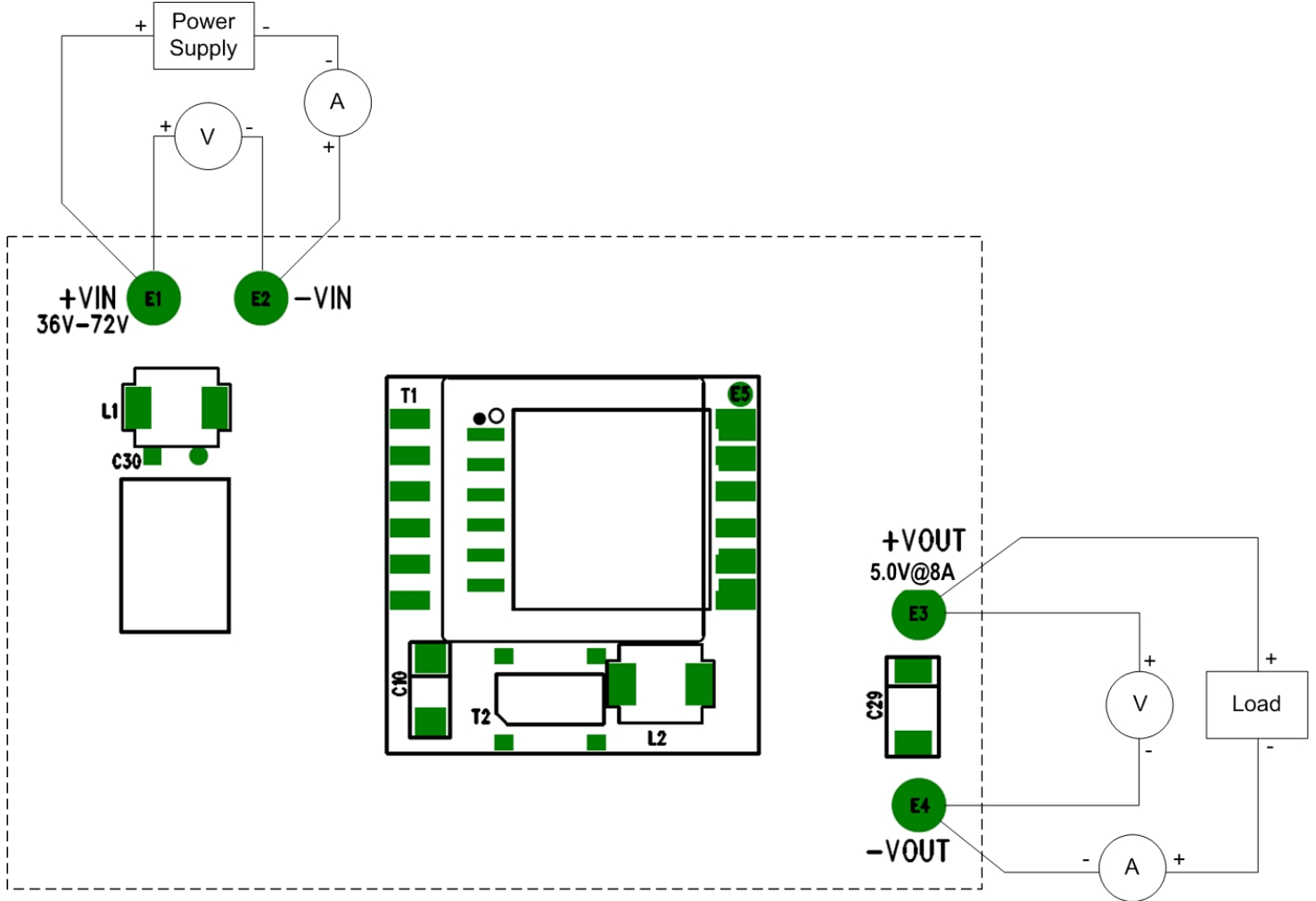

Figure 1. Proper Measurement Equipment Setup

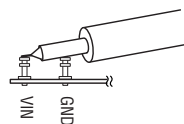

Figure 2. Measuring Input or Output Ripple

MEASURED DATA

Figures 3 through 10 are measured data for a typical DC894C-B. Figures 11 through 13 are schematics and bill of materials.

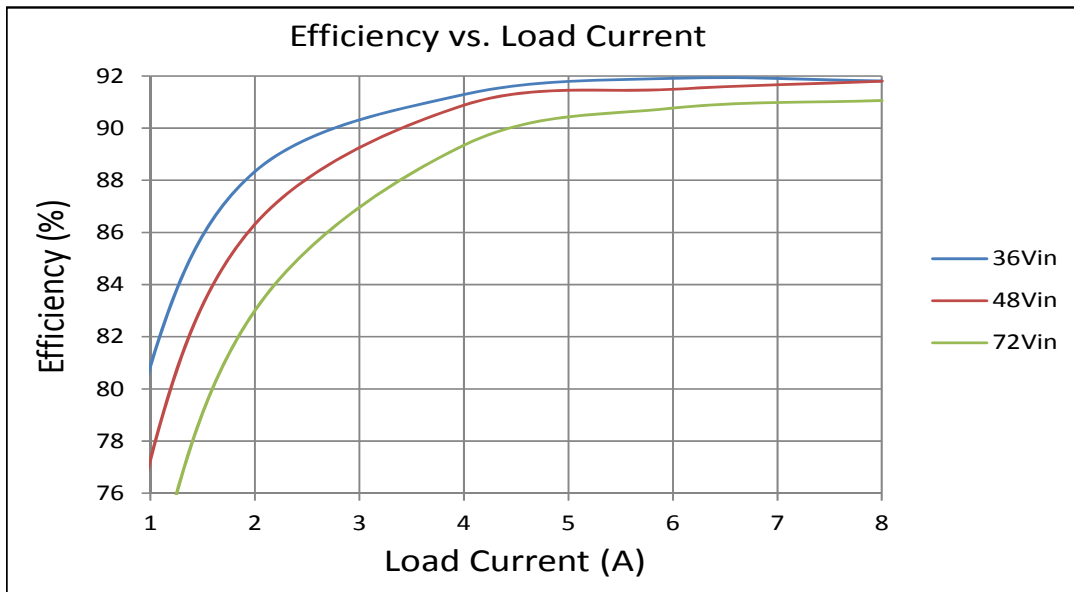

Figure 3. Efficiency (no airflow)

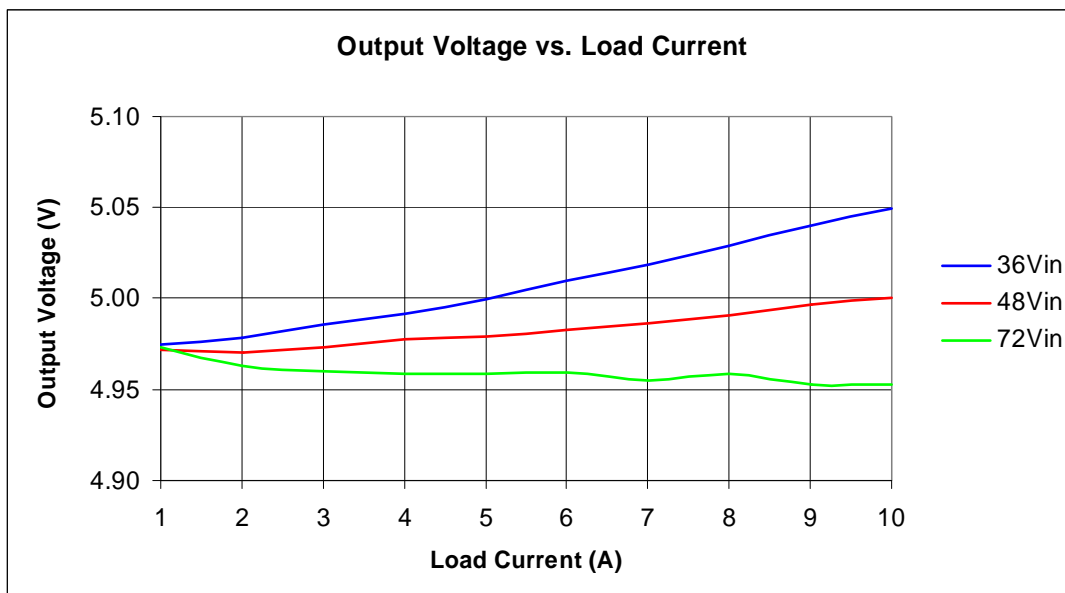

Figure 4. Regulation (no airflow)

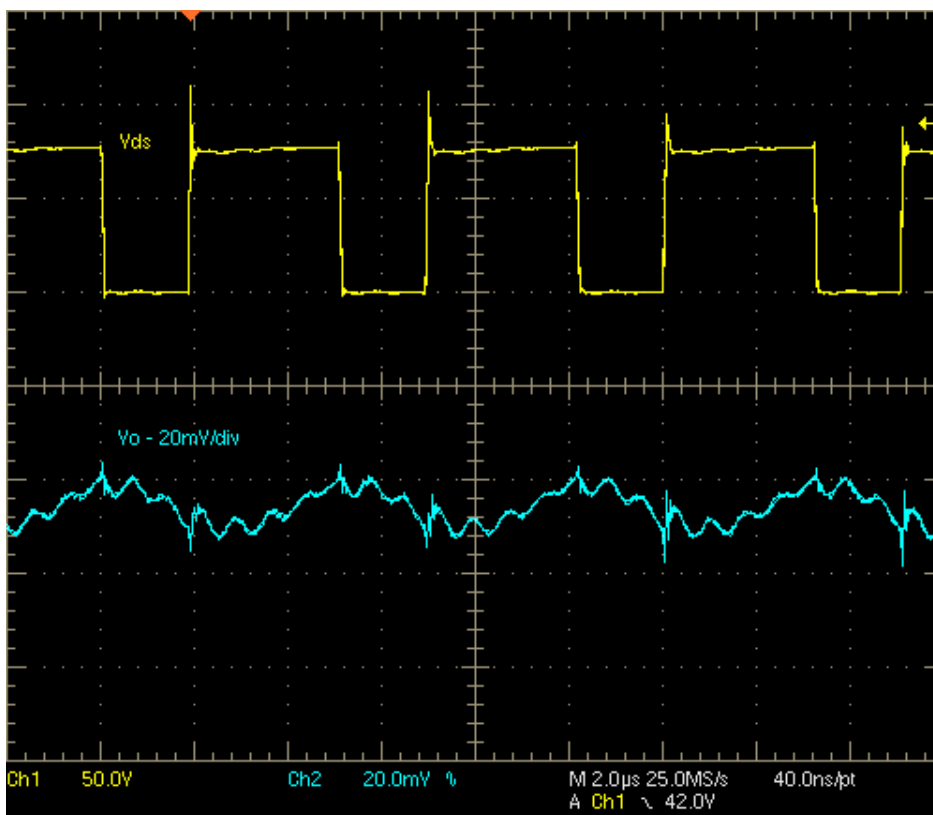

Figure 5. Output Voltage Ripple (48Vin 8A)

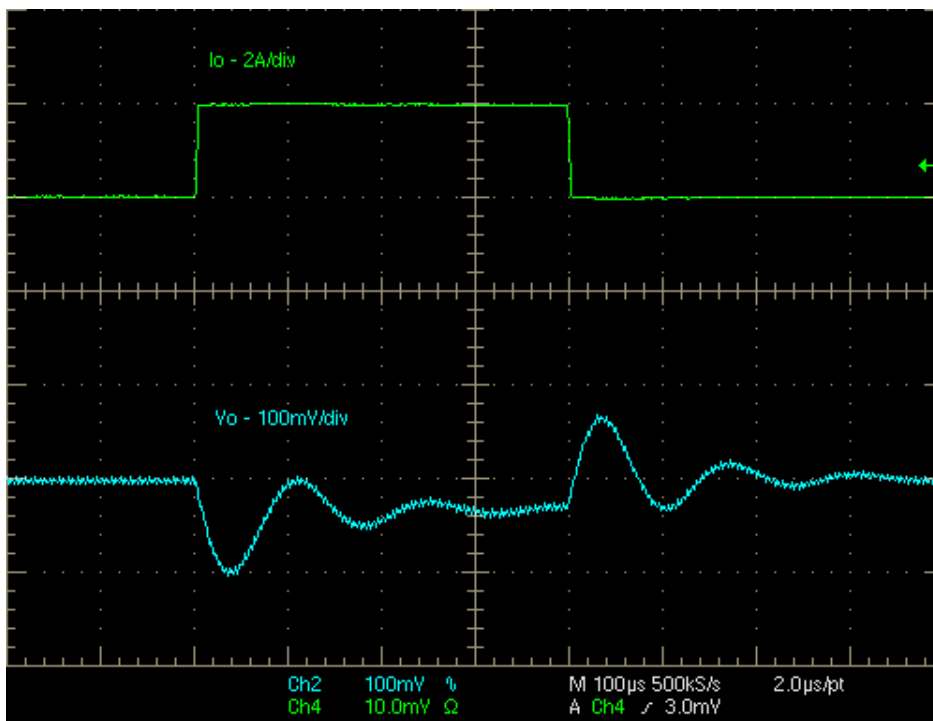

Figure 6. Load Transient Response (10A/us)

QUICK START GUIDE FOR DEMONSTRATION CIRCUIT 894C-B 36V-72VIN, SYNCHRONOUS FLYBACK

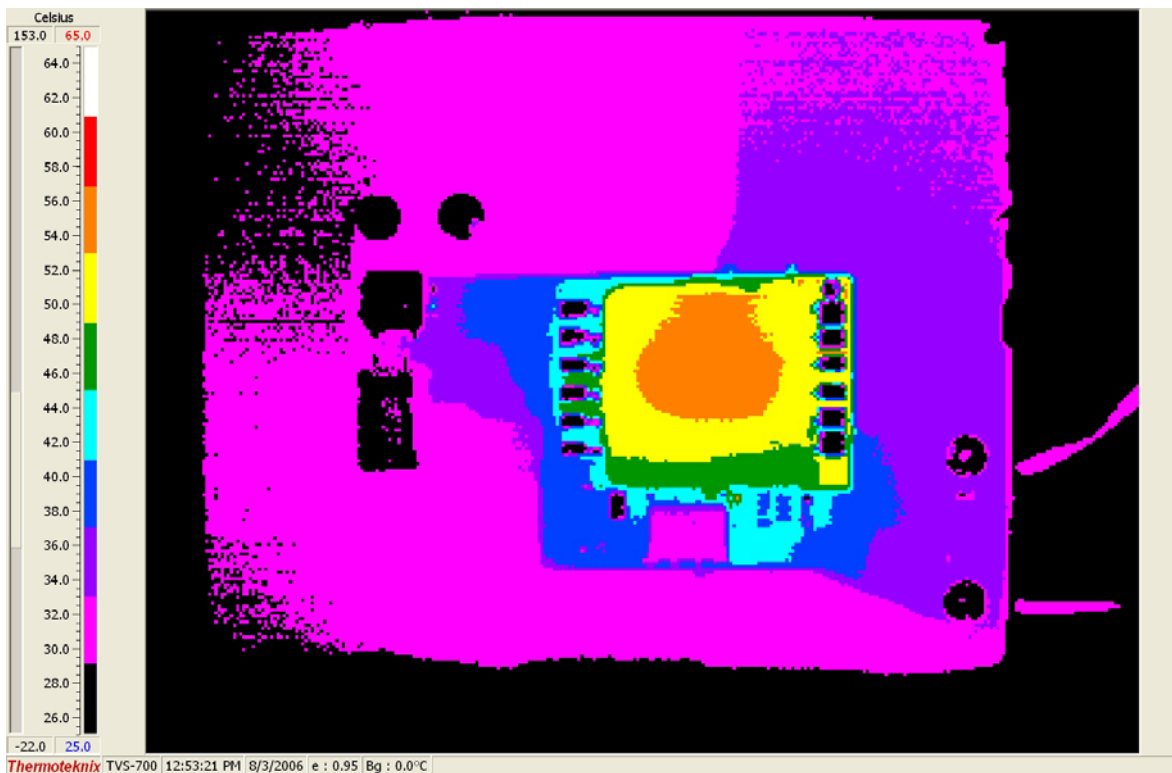

Figure 7. Temp Data (48Vin, 8A, 100LFM airflow – front)

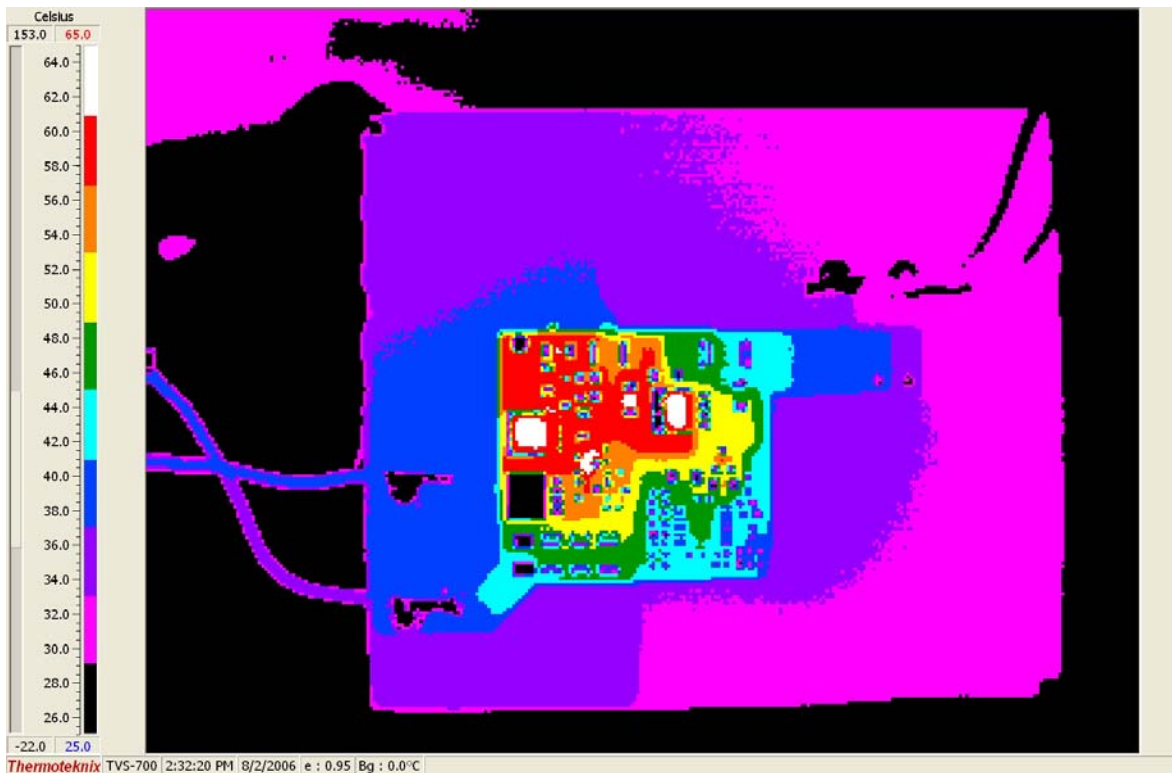

Figure 8. Temp Data (48Vin, 8A, 100LFM airflow – back)

QUICK START GUIDE FOR DEMONSTRATION CIRCUIT 894C-B

36V-72VIN, SYNCHRONOUS FLYBACK

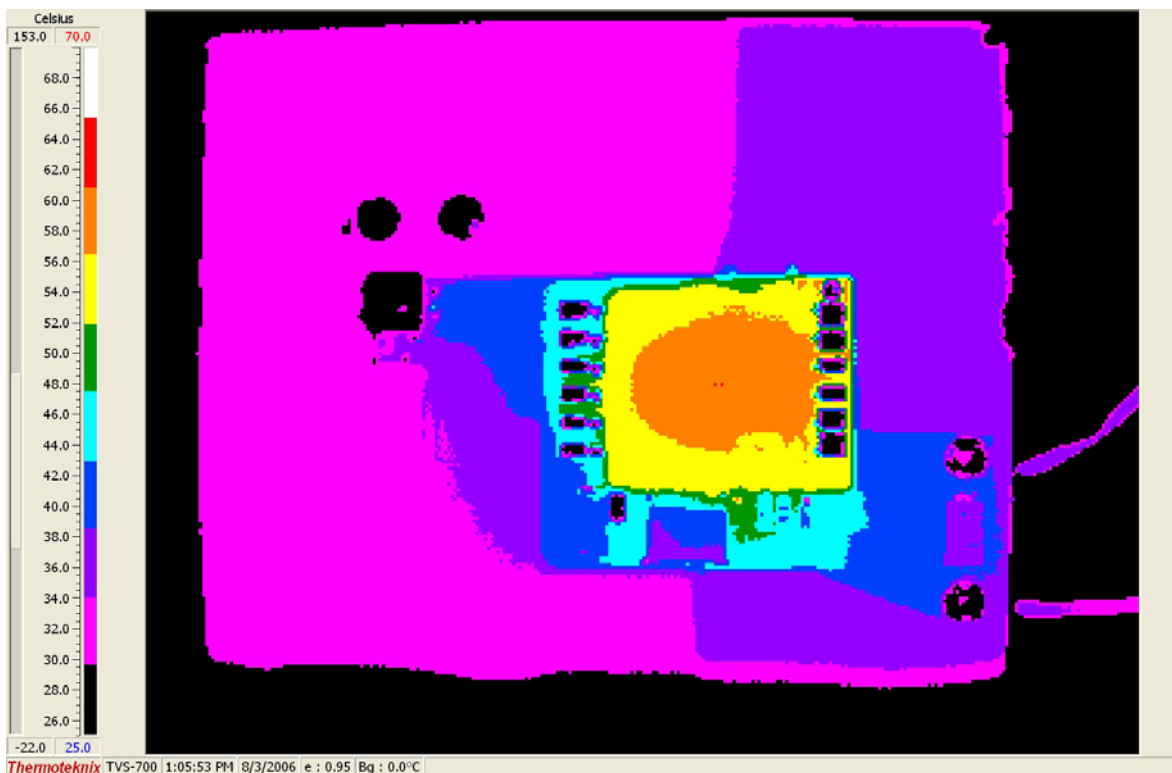

Figure 9. Temp Data (48Vin, 8A, no airflow – front)

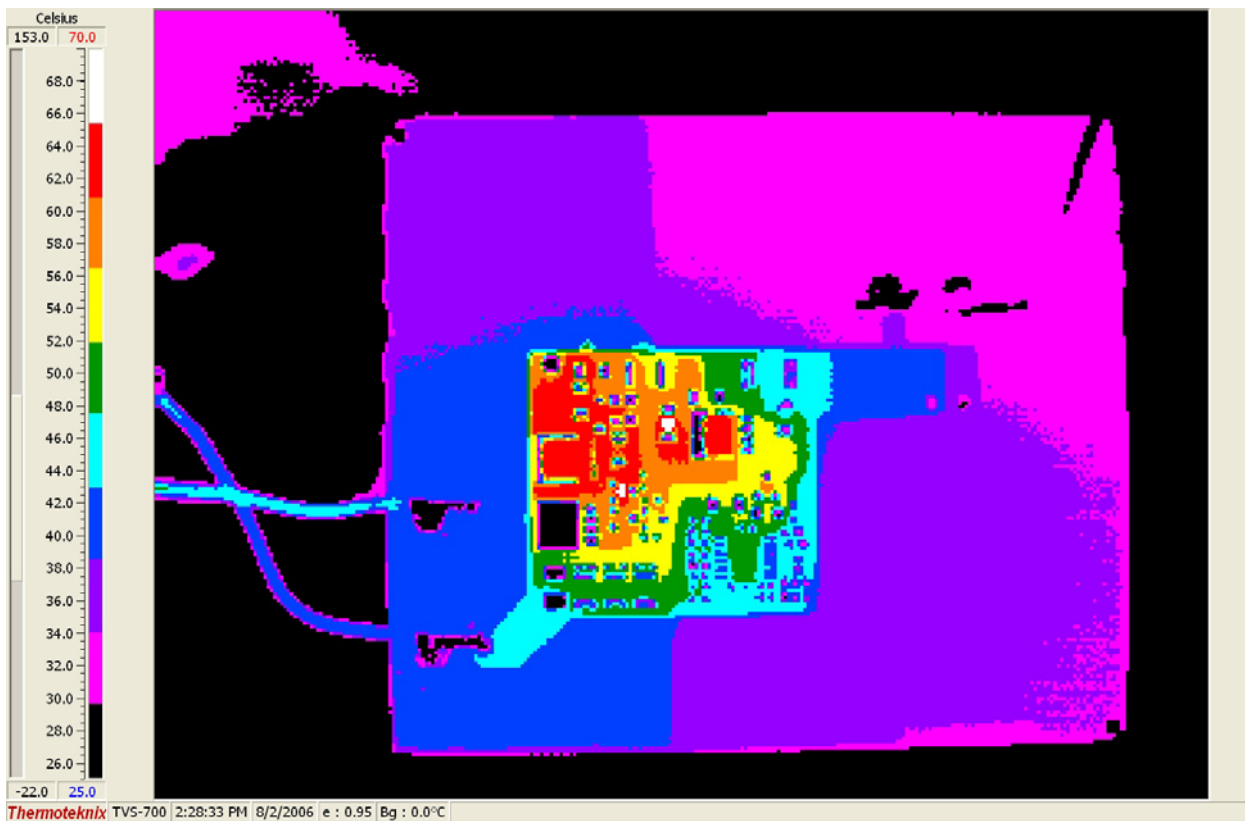

Figure 10. Temp Data (48Vin, 8A, no airflow – back)

QUICK START GUIDE FOR DEMONSTRATION CIRCUIT 894C-B 36V-72VIN, SYNCHRONOUS FLYBACK

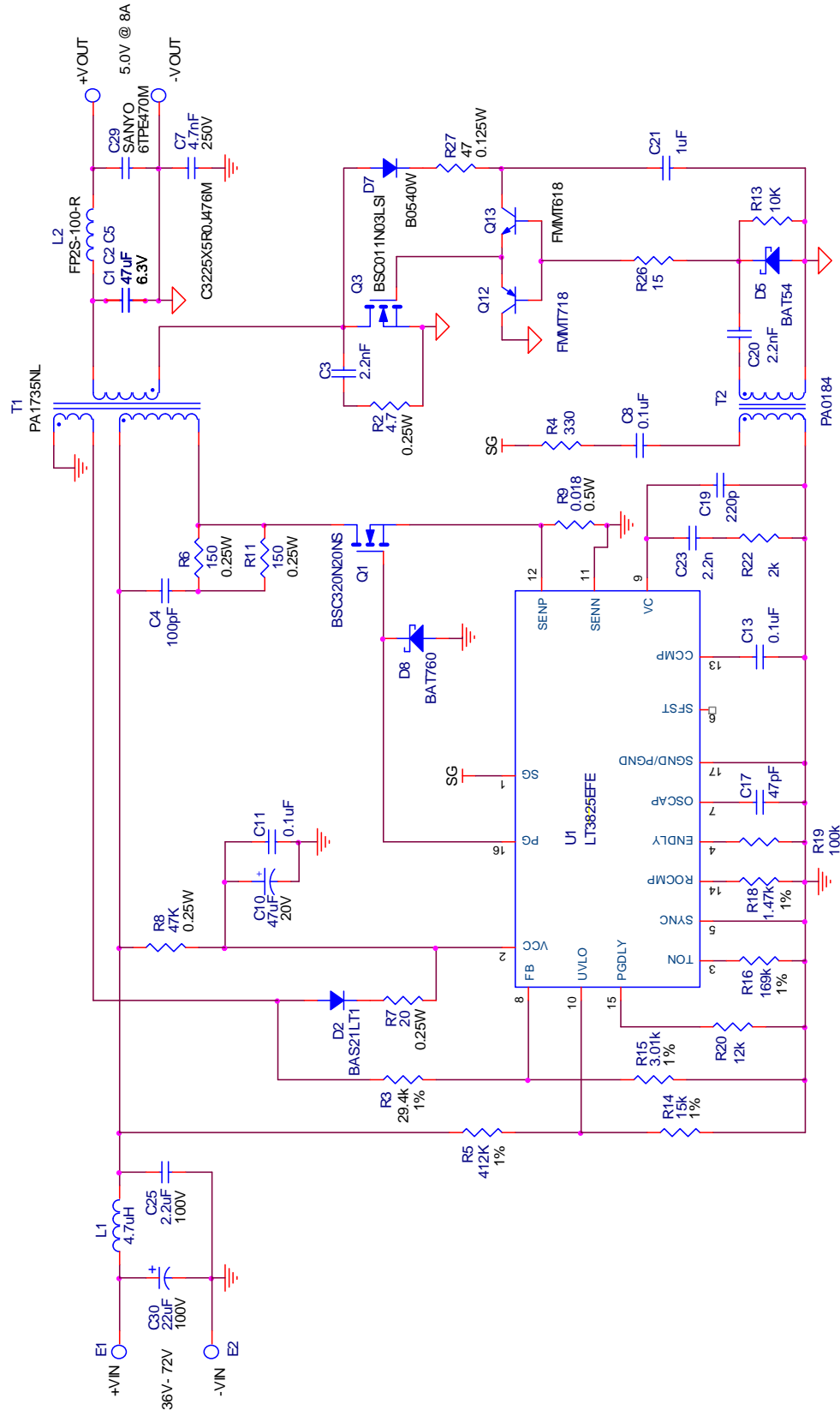

Figure 11. Simplified Schematic

QUICK START GUIDE FOR DEMONSTRATION CIRCUIT 894C-B

36V-72VIN, SYNCHRONOUS FLYBACK

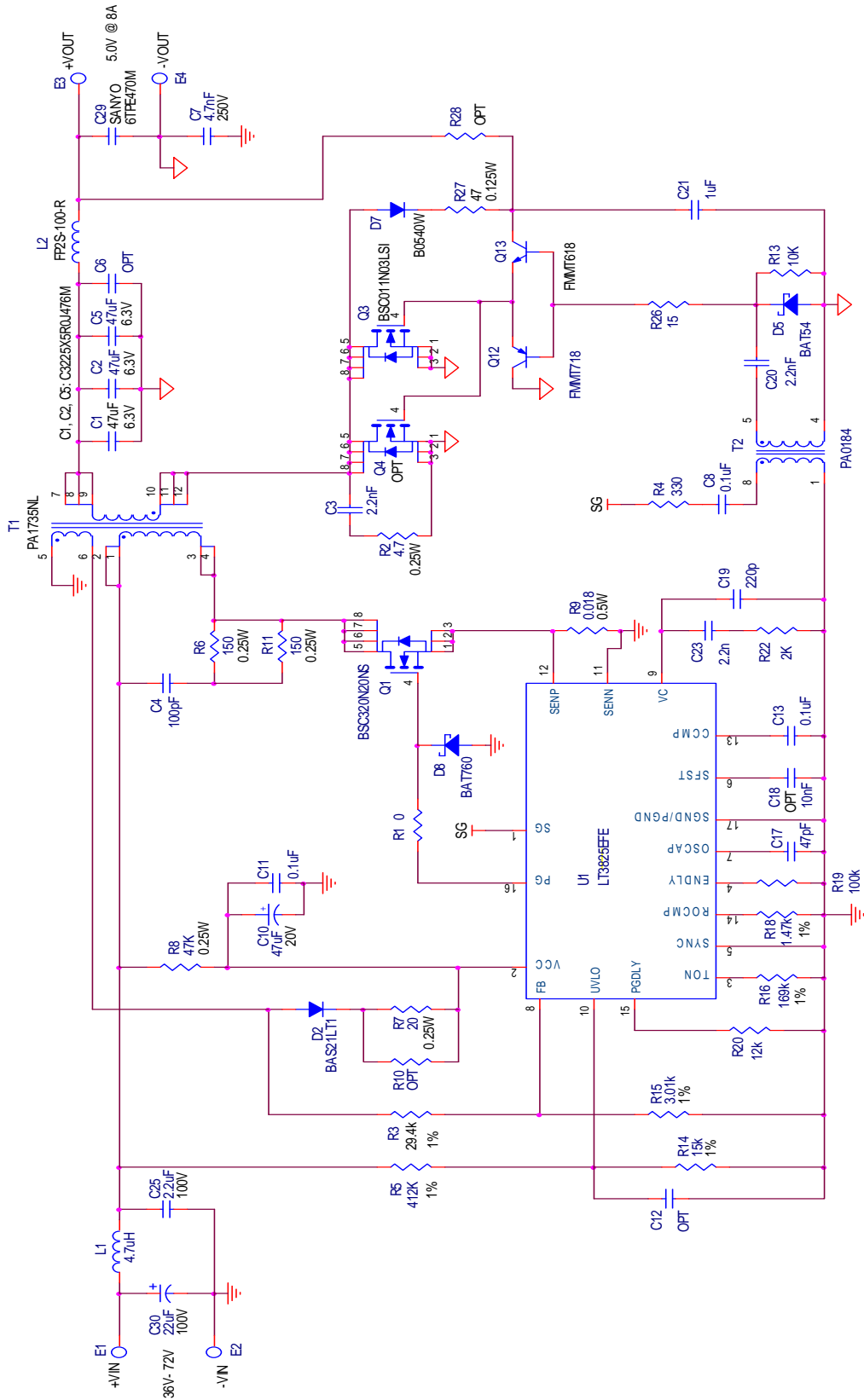

Figure 12. Full Board Schematic

QUICK START GUIDE FOR DEMONSTRATION CIRCUIT 894C-B

36V-72VIN, SYNCHRONOUS FLYBACK

<i>Item</i>	<i>Qty</i>	<i>Ref-Des</i>	<i>Description</i>	<i>Manufacturer's Part Number</i>
REQUIRED CIRCUIT COMPONENTS¹				
1	1	C3	CAP, 1206 2.2nF 20% 100V X7R	AVX 12061C222MAT
2	1	C4	CAP, 1206 100pF 10% 630V COG	TDK C3216COG2J101K
3	3	C5,C2,C1	CAP, 1210 47uF 20% 6.3V X5R	TDK C3225X5R0J476MT
4	1	C7	CAP, 4.7nF 10% 250V X7R	MURATA GA343DR7GD472KW01L
5	3	C8,C11,C13	CAP, 0603 0.1uF 10% 50V X7R	TDK C1608X7R1H104K
6	1	C10	CAP, 6032 47uF 20% 20V TANT	AVX TAJC476M020R
7	0	C12	CAP, 0603 470pF 10% 25V NPO	AVX 06033A471KAT2A OPTION
8	1	C17	CAP, 0603 47pF 10% 25V NPO	AVX 06033A470KAT2A
9	1	C19	CAP, 0603 220pF 5% 50V COG	AVX 06035A221JAT
10	1	C20	CAP, 0603 2.2nF 5% 50V X7R	AVX 06035C222JAT
11	1	C21	CAP, 1206 1uF 20% 25V X7R	AVX 12063C105MAT2A
12	1	C23	CAP, 0603 2.2nF 5% 50V X7R	AVX 06035C222JAT
13	1	C25	CAP, 1812 2.2uF 10% 100V X7R	TDK C4532X7R2A225K
14	1	C29	CAP, 7343 470uF 20% 6.3V POSCAP	SANYO 6TPE470M
15	1	D2	DIODE, BAS21-7	DIODES INC. BAS21-7-F
16	1	D5	DIODE, SCHOTTKY	DIODES INC. BAT54-7
17	1	D7	DIODE, SCHOTTKY	DIODES INC. B0540W-7-F
18	1	D8	DIODE, SCHOTTKY	DIODES INC. BAT760-7
19	1	L2	IND, 0.1uH	COILTRONICS FP2S-100-R
20	1	Q1	MOSFET, N-CH 200V 36A TDSO-8	INFINEON, BSC320N20NS3 G
21	1	Q3	MOSFET, N-CH 30V 37A TDSO-8	INFINEON, BSC011N03LSI
22	1	Q12	XSTR, PNP	ZETEX FMMT718TA
23	1	Q13	XSTR, NPN	ZETEX FMMT618TA
24	1	R2	RES, 1206 4.7 OHMS 5% 1/4W	VISHAY, CRCW12064K70JNEA
25	1	R3	RES, 0603 29.4K OHMS 1% 1/10W	VISHAY, CRCW060329K4FKEA
26	1	R4	RES, 0603 330 OHMS 5% 1/10W	VISHAY, CRCW0603330RJNEA
27	1	R5	RES, 0603 412K OHMS 1% 1/10W	VISHAY, CRCW0603412KFKEA
28	2	R6,R11	RES, 1206 150 OHMS 5% 1/4W	VISHAY, CRCW1206150RJNEA
29	1	R7	RES, 1206 20 OHMS 5% 1/4W	VISHAY, CRCW120620R0JNEA
30	1	R8	RES, 1206 47K OHMS 5% 1/4W	VISHAY, CRCW120647K0JNEA
31	1	R9	RES, 1206 0.018 OHMS 1% 0.5W	SUSUMU, RL1632T-R018-G
32	1	R13	RES, 0603 10K OHMS 5% 1/10W	VISHAY, CRCW060310K0JNEA
33	1	R14	RES, 0603 15K OHMS 1% 1/10W	VISHAY, CRCW060315K0FKEA
34	1	R15	RES, 0603 3.01K OHMS 1% 1/10W	VISHAY, CRCW06033K01FKEA
35	1	R16	RES, 0603 169K OHMS 1% 1/10W	VISHAY, CRCW0603169KFKEA
36	1	R18	RES, 0603 1.47K OHMS 1% 1/10W	VISHAY, CRCW06031K47FKEA
37	1	R19	RES, 0603 100K OHMS 5% 1/10W	VISHAY, CRCW0603100KJNEA
38	1	R20	RES, 0603 12K OHMS 5% 1/10W	VISHAY, CRCW060312K0JNEA
39	1	R22	RES, 0603 2K OHMS 5% 1/10W	VISHAY, CRCW06032K00JNEA
40	1	R26	RES, 0603 15 OHMS 5% 1/10W	VISHAY, CRCW060315R0JNEA
41	1	R27	RES, 0805 47 OHMS 5% 1/8W	VISHAY, CRCW080547R0JNEA
42	1	T1	XFMR, PA1735NL	PULSE PA1735NL
43	1	T2	XFMR, 1.4mH MIN, 50KHz	PULSE PA0184NL
44	1	U1	IC, LT3825EFE	LINEAR TECH LT3825EFE
ADDITIONAL DEMO BOARD CIRCUIT COMPONENTS²				
45	0	C6	CAP, 1210 47uF 20% 6.3V X5R OPTION	TDK C3225X5R0J476MT OPTION

QUICK START GUIDE FOR DEMONSTRATION CIRCUIT 894C-B

36V-72VIN, SYNCHRONOUS FLYBACK

46	0	C18	CAP, 0603 10nF 10% 25V X7R OPTION	AVX 06033C103KAT OPTION
47	1	C30	CAP, 22uF 100V	SUN ELECTRONIC 100ME22AX
48	1	L1	IND, 4.7uH	VISHAY IHPL2525CZER4R7M01
49	0	Q4	MOSFET N-CHANNEL OPTION	INFINEON, BSC011N03LSI OPTION
50	1	R1	RES, 0603 0 OHM JUMPER	VISHAY, CRCW06030000Z0EA
51	0	R10	RES, 1206 OPTIONAL	OPTION
52	0	R28	RES, 0805 OPTION	OPTION

Notes:

1. Required Circuit Components are those parts that are required to implement the circuit function
2. Additional Demo Board Circuit Components are those parts that provide added functionality for the demo board but are or may not be required in the actual circuit.

Figure 13. Bill of Materials

X-ON Electronics

Largest Supplier of Electrical and Electronic Components

Click to view similar products for [Power Management IC Development Tools](#) category:

Click to view products by [Analog Devices](#) manufacturer:

Other Similar products are found below :

[EVAL-ADM1168LQEBZ](#) [EVB-EP5348UI](#) [MIC23451-AAAYFL EV](#) [MIC5281YMME EV](#) [DA9063-EVAL](#) [ADP122-3.3-EVALZ](#) [ADP130-0.8-EVALZ](#) [ADP130-1.2-EVALZ](#) [ADP130-1.5-EVALZ](#) [ADP130-1.8-EVALZ](#) [ADP1714-3.3-EVALZ](#) [ADP1716-2.5-EVALZ](#) [ADP1740-1.5-EVALZ](#) [ADP1752-1.5-EVALZ](#) [ADP1828LC-EVALZ](#) [ADP1870-0.3-EVALZ](#) [ADP1871-0.6-EVALZ](#) [ADP1873-0.6-EVALZ](#) [ADP1874-0.3-EVALZ](#) [ADP1882-1.0-EVALZ](#) [ADP199CB-EVALZ](#) [ADP2102-1.25-EVALZ](#) [ADP2102-1.875EVALZ](#) [ADP2102-1.8-EVALZ](#) [ADP2102-2-EVALZ](#) [ADP2102-3-EVALZ](#) [ADP2102-4-EVALZ](#) [ADP2106-1.8-EVALZ](#) [ADP2147CB-110EVALZ](#) [AS3606-DB](#) [BQ24010EVM](#) [BQ24075TEVM](#) [BQ24155EVM](#) [BQ24157EVM-697](#) [BQ24160EVM-742](#) [BQ24296MEVM-655](#) [BQ25010EVM](#) [BQ3055EVM](#) [NCV891330PD50GEVB](#) [ISLUSBI2CKIT1Z](#) [LM2744EVAL](#) [LM2854EVAL](#) [LM3658SD-AEV/NOPB](#) [LM3658SDEV/NOPB](#) [LM3691TL-1.8EV/NOPB](#) [LM4510SDEV/NOPB](#) [LM5033SD-EVAL](#) [LP38512TS-1.8EV](#) [EVAL-ADM1186-1MBZ](#) [EVAL-ADM1186-2MBZ](#)