

QUICK START GUIDE FOR DEMONSTRATION CIRCUIT 920 STAND ALONE LI-ION CHARGER WITH SYNCHRONOUS BUCK REGULATOR

LTC4080

DESCRIPTION

Demonstration circuit 920 is a complete single cell Lithium-Ion battery charger and adjustable output voltage buck switching regulator. Operating at a frequency of 2.25MHz, the 300mA synchronous regulator is powered from the Li-Ion battery.

This demonstration circuit allows the user to quickly evaluate the LTC4080 performance. Individual jumpers are provided for shutting down the charger and/or the switching regulator, for selecting several regulated output voltages and the mode of operation (fixed frequency or Burst). LEDs indicate charger status (input power and charge) and pins on the board allow

easy hookup to an input supply and battery or battery simulator.

The high switching frequency of the voltage regulator allow tiny LC components to be used and the 10-Pin 3mm x 3mm DFN thermally enhanced package with the metal backside allow the linear charger to provide up to 500mA of charge current in addition to the regulator output current.

Design files for this circuit board are available. Call the LTC factory.

LTC and Burst Mode are trademarks of Linear Technology Corporation

Table 1. Typical Specifications (25 °C)

Input Voltage Range V_{IN}	3.75V to 5.5V
Output Charger Float Voltage V_{BAT} (constant voltage mode)	4.2V \pm 0.5%
Output Current I_{BAT} (constant current mode)	500mA \pm 5%
Current Monitor Output	1V \pm 1.5% @ Full Current
Charge Termination Timer	4.5 Hours \pm 25%
C/10 Output Indication Level (CHRG)	50mA \pm 10%
1.2V Regulator V_{OUT} (100ma)	1.2V \pm 2.5%
1.5V Regulator V_{OUT} (100ma)	1.5V \pm 2.5%
1.8V Regulator V_{OUT} (100ma)	1.8V \pm 2.5%
2.5V Regulator V_{OUT} (100ma)	2.5V \pm 2.5%
Regulator Output Ripple Voltage (fixed frequency)	5mV p-p
Regulator Output Ripple Voltage (burst mode)	50mV p-p
Buck Regulator Maximum Output Current (fixed frequency)	350mA

OPERATION

The battery charger portion of demonstration circuit 920 uses a constant-current/constant voltage charge algorithm with timer charge termination. The battery float voltage is fixed at 4.2V and the charge current is programmed for

500mA, although a lower charge current can be programmed by replacing the program resistor (R5) with a suitable value. Either a leaded resistor, from PROG to GND, or a 0402 surface mount resistor can be used.

QUICK START GUIDE FOR DEMONSTRATION CIRCUIT 920

STAND ALONE LI-ION CHARGER WITH SYNCHRONOUS BUCK REGULATOR

Power and Charge LEDs indicate charger status. The Power LED indicates that the input voltage is greater than the undervoltage lock-out threshold level.

The Charge LED has three states. With a battery connected, the LED is on when either trickle current is flowing ($V_{BAT} < 2.9V$) or when charge current greater than 10% of the programmed value is flowing ($V_{BAT} > 2.9V$). When the battery voltage approaches the float voltage, the charge current will begin to drop. When it drops below 10%, the Charge LED goes out, indicating that the battery is near full charge. Charging continues until the timer ends the charge cycle. During a trickle charge, if the battery voltage does not exceed 2.9V after $\frac{1}{4}$ of the total charge time, the battery is considered defective, charging ends and the Charge LED flashes at a 2Hz rate.

With no battery connected, there is a condition where the Charge LED will be on with very little or no charge current flowing. This occurs with low input voltage. When the input voltage exceeds approximately 3.5V, the Power and Charge LEDs come on. Above 4.3V, the Charge LED goes off.

The charger jumper (JP1) can be used to shut down the charger and reset the timer. The

PROG terminal can be used to program different charge current and also measure the charge current anytime in the charge cycle. The PROG pin voltage is directly proportional to the charge current where one Volt is equal to full programmed current.

After the charge cycle has ended, if the battery voltage drops approximately 100mV, a new 2.25 hour recharge cycle will begin.

The 2.25MHz synchronous buck regulator has jumper selected output voltages of 1.2V, 1.5V, 1.8V and 2.5V with output current up to 300mA. Jumpers are also provided for low quiescent current shutdown and for either fixed frequency or Burst mode operation. Burst mode provides high efficiency at low load current. The input power for the regulator comes from the BAT pin. Normally, a Li-Ion battery would be connected to the BAT pin, although the buck regulator can be operated without a battery. When no battery is present, some additional capacitance on the BAT pin may be needed. Also, when the termination timer ends, the BAT voltage will begin to drop. When it drops below the recharge threshold, the timer is reset and the charger output voltage returns to the float voltage of 4.2V.

QUICK START GUIDE FOR DEMONSTRATION CIRCUIT 920 STAND ALONE LI-ION CHARGER WITH SYNCHRONOUS BUCK REGULATOR

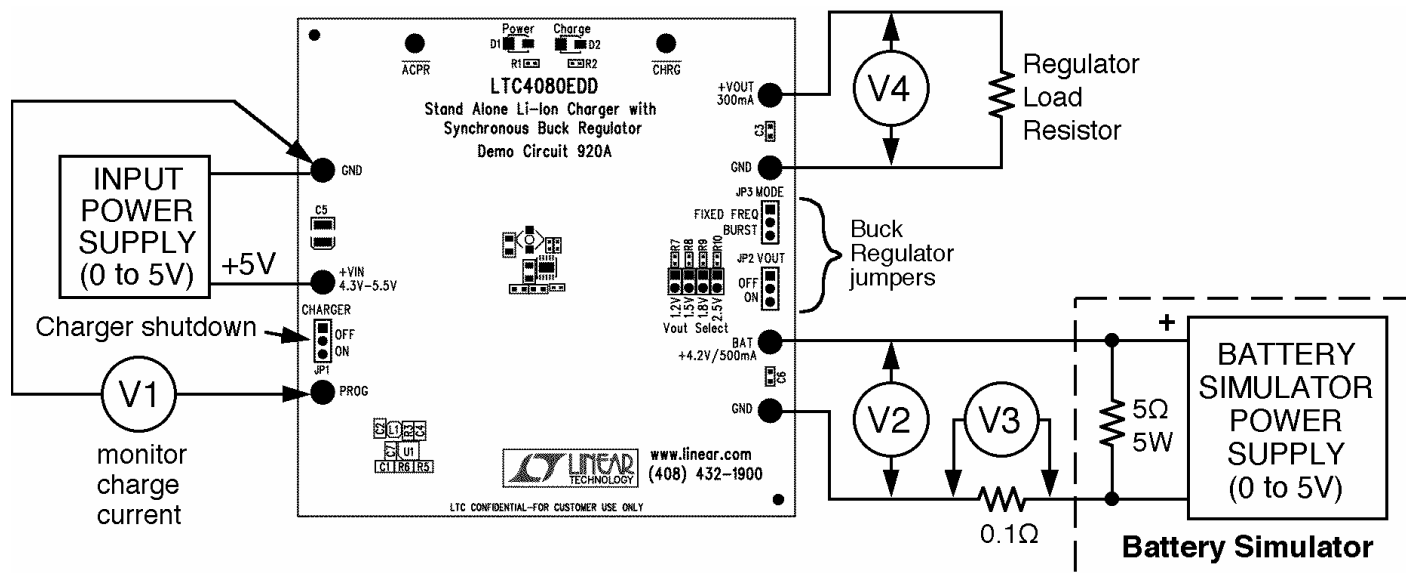

Figure 1. Demonstration Circuit Test Setup

QUICK START PROCEDURE

The charger section can be evaluated using an actual Lithium Ion battery or a battery simulator. The battery simulator is faster because all battery state-of-charge conditions can be quickly simulated.

Battery Simulator

A battery simulator consists of an adjustable power supply with a load resistor across the power supply output. The load resistor allows the battery simulator to source and sink current, similar to an actual battery. Any battery state-of-charge condition can be quickly simulated by simply changing the power supply output voltage. The load resistor value is selected that will sink at least 500mA when the power supply is set for 2.5V and the power supply must provide at least 850mA when adjusted for 4.2V. For this battery simulator, a 5 Ohm, 5 Watt power resistor connected to the output of a 5V, 1A bench supply will work fine.

Battery Charger

Begin circuit evaluation by moving the jumpers to the appropriate positions. With the input power supply and battery simulator power supply adjusted to 0V, connect the demonstration circuit as shown in Figure 1.

Begin increasing the input supply voltage, up to 5V. At approximately 3.6V (the undervoltage lockout threshold), the Power and Charge LEDs will turn ON and the preconditioning trickle charge of 50mA will begin flowing into the battery or battery simulator. The PROG pin voltage (Voltmeter V1) will measure 100mV indicating 10% of the programmed current. Adjust the battery simulator power supply to 3V as measured by V2. At approximately 2.9V, the charge current will abruptly increase to the programmed constant current of 500mA. Voltmeter V1 will measure 1 Volt and V3 will measure 50mV indicating full charge current is

QUICK START GUIDE FOR DEMONSTRATION CIRCUIT 920 STAND ALONE LI-ION CHARGER WITH SYNCHRONOUS BUCK REGULATOR

flowing. Continue slowly increasing the battery simulator power supply, thus simulating the Li-Ion battery accepting charge. As the battery simulator approaches the float voltage of 4.200V, as measured by V2, the charge current will begin to drop as the charger begins the constant voltage portion of the charge cycle. When the charger is in the constant voltage portion of the charge cycle, small changes in the simulator power supply voltage will result in relatively large changes in charge current. The PROG terminal can be used to indicate charge current level at all times during the charge cycle with 1 Volt indicating 100% of the programmed current. When the charge current drops below the End-of-Charge threshold level of 50mA, the Charge, LED will go OFF indicating the battery is near full charge. The charge cycle will continue until the 4.5 hour timer ends.

The one Ohm resistor in series with the ceramic input capacitor on Vcc minimizes the ringing and overshoot that appears at the input when the input voltage is hot switched. Without the series resistor, serious damage to the LTC4080 can occur. See Figure 2. Pads are also included

for an additional input capacitor. Adding a tantalum capacitor at this location will also minimize voltage ringing and overshoot.

Buck Regulator

Select one of the four output voltages using jumpers JP4 through JP7. (With no jumpers installed, the output voltage is set to the reference voltage of 800mV.) With jumpers JP3 in the fixed frequency position, JP1 and JP2 in the ON position, connect a suitable load resistor between VOUT and GND terminals. The maximum load current is approximately 300mA. Verify that the output voltage, as measured by V4 is between the limits as shown in Table 1. A scope can also be used to measure the regulator output ripple voltage. When evaluating output ripple, observe proper scope probe measuring technique as shown in Figure 3. For high efficiency at light load conditions, move jumper J3 to the BURST position. In Burst mode, the output ripple voltage is higher (20 - 40mV) and the maximum output current is approximately 50mA.

See LTC4080 Data Sheet for additional information.

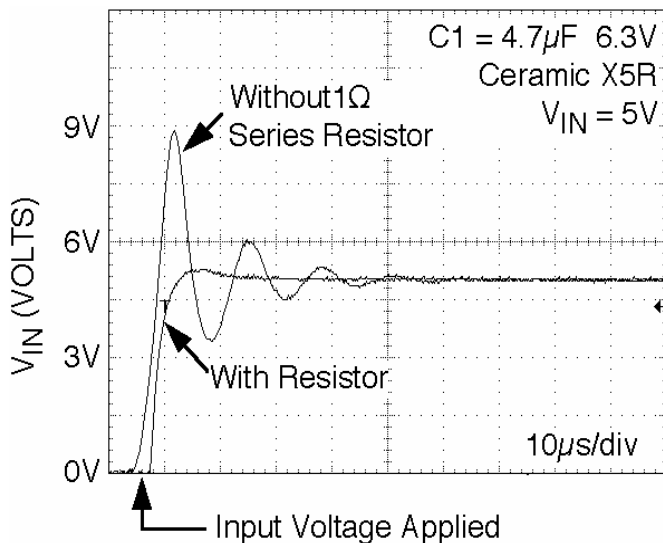

Figure 2. Input Voltage Transient When Input Power is Hot Switched

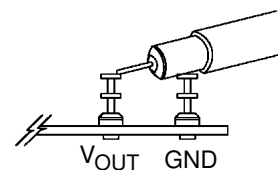
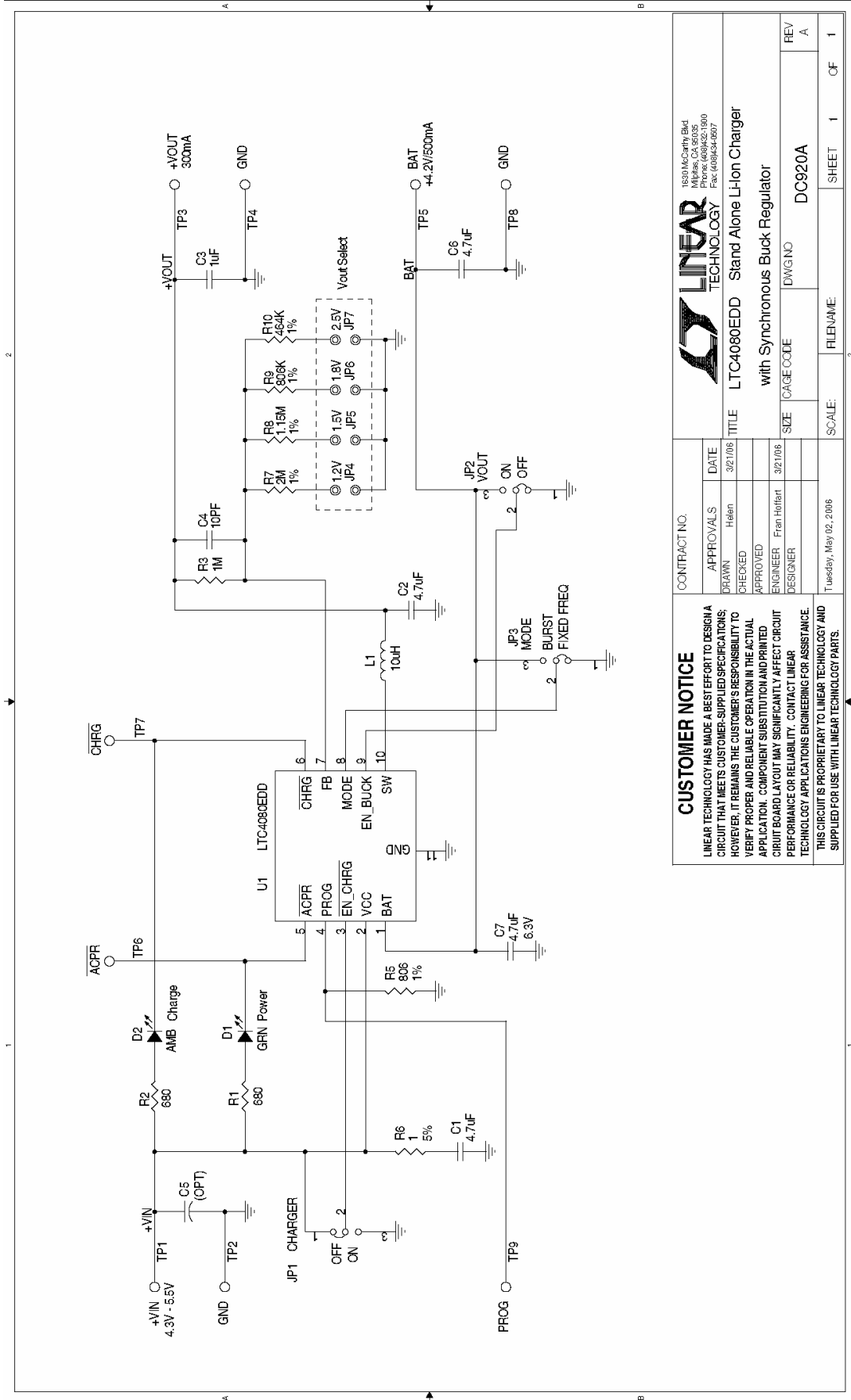

Figure 3. Scope Probe Placement for Measuring Output Ripple Voltage

QUICK START GUIDE FOR DEMONSTRATION CIRCUIT 920 STAND ALONE LI-ION CHARGER WITH SYNCHRONOUS BUCK REGULATOR



CUSTOMER NOTICE		CONTRACT NO.	APPROVALS	DATE
LINEAR TECHNOLOGY HAS MADE A BEST EFFORT TO DESIGN A CIRCUIT THAT MEETS CUSTOMER-SUPPLIED SPECIFICATIONS; HOWEVER, IT REMAINS THE CUSTOMER'S RESPONSIBILITY TO VERIFY PROPER AND RELIABLE OPERATION IN THE ACTUAL APPLICATION. COMPONENT SUBSTITUTION AND PRINTED CIRCUIT BOARD LAYOUT MAY SIGNIFICANTLY AFFECT CIRCUIT PERFORMANCE OR RELIABILITY. CONTACT LINEAR TECHNOLOGY APPLICATIONS ENGINEERING FOR ASSISTANCE.		DRAWN	Helen	3/27/06
THIS CIRCUIT IS PROPRIETARY TO LINEAR TECHNOLOGY AND SUPPLIED FOR USE WITH LINEAR TECHNOLOGY PARTS.		CHECKED		
		APPROVED	Fren Horibart	3/27/06
		ENGINEER	Fren Horibart	
		DESIGNER		
		SIZE	CAGE CODE	DWG NO
				DC920A
		SCALE:	FILENAME:	SHEET 1 OF 1
		Tuesday, May 02, 2006		REV A

X-ON Electronics

Largest Supplier of Electrical and Electronic Components

Click to view similar products for [Power Management IC Development Tools](#) category:

Click to view products by [Analog Devices](#) manufacturer:

Other Similar products are found below :

[EVAL-ADM1168LQEBZ](#) [EVB-EP5348UI](#) [MIC23451-AAAYFL EV](#) [MIC5281YMME EV](#) [DA9063-EVAL](#) [ADP122-3.3-EVALZ](#) [ADP130-0.8-EVALZ](#) [ADP130-1.2-EVALZ](#) [ADP130-1.5-EVALZ](#) [ADP130-1.8-EVALZ](#) [ADP1714-3.3-EVALZ](#) [ADP1716-2.5-EVALZ](#) [ADP1740-1.5-EVALZ](#) [ADP1752-1.5-EVALZ](#) [ADP1828LC-EVALZ](#) [ADP1870-0.3-EVALZ](#) [ADP1871-0.6-EVALZ](#) [ADP1873-0.6-EVALZ](#) [ADP1874-0.3-EVALZ](#) [ADP1882-1.0-EVALZ](#) [ADP199CB-EVALZ](#) [ADP2102-1.25-EVALZ](#) [ADP2102-1.875EVALZ](#) [ADP2102-1.8-EVALZ](#) [ADP2102-2-EVALZ](#) [ADP2102-3-EVALZ](#) [ADP2102-4-EVALZ](#) [ADP2106-1.8-EVALZ](#) [ADP2147CB-110EVALZ](#) [AS3606-DB](#) [BQ24010EVM](#) [BQ24075TEVM](#) [BQ24155EVM](#) [BQ24157EVM-697](#) [BQ24160EVM-742](#) [BQ24296MEVM-655](#) [BQ25010EVM](#) [BQ3055EVM](#) [NCV891330PD50GEVB](#) [ISLUSBI2CKIT1Z](#) [LM2744EVAL](#) [LM2854EVAL](#) [LM3658SD-AEV/NOPB](#) [LM3658SDEV/NOPB](#) [LM3691TL-1.8EV/NOPB](#) [LM4510SDEV/NOPB](#) [LM5033SD-EVAL](#) [LP38512TS-1.8EV](#) [EVAL-ADM1186-1MBZ](#) [EVAL-ADM1186-2MBZ](#)