

DESCRIPTION

Demonstration circuit DC929A-A/B is a monolithic high voltage (6V-36V) switching buck regulator, USB Powerpath controller, and Li-Ion battery charger. It is based on the LTC4089/-5 and provides the following functions: 1.2A monolithic buck regulator with output voltage tracking battery voltage V_{BAT} , a 700mA CC/CV timer terminated temperature qualified charger suitable for Li-Ion cells, a USB power manager that insures compliance with the USB power specification and Powerpath management for the battery. The LTC4089/-5 uses the in-

termediate bus voltage topology that results in faster charging and lower power loss than the charger fed topology. All this functionality consumes less than 2cm² of PCB area with all components on one side of the PCB.

Design files for this circuit board are available. Call the LTC factory.

 , LTC , LT, and Powerpath are registered trademarks of Linear Technology Corporation.

Table 1. Performance Summary

PARAMETER	CONDITION	VALUE
HVIN Input Voltage		6V - 36V
HVOUT/VOUT	$V_{HVIN} = 6V - 36V$	= $V_{BAT} + 0.3V$ (for LTC4089) = 5V (for LTC4089-5)
Battery Charger		
I_{BAT}	$V_{USB} = 5V$, $V_{bat} = 3.6V$	700mA +/- 7%
Float Voltage	$V_{USB} = 5V$, battery disconnected from BATT pin	4.20V +/- 35mV
Trickle Charge Threshold	$V_{USB} = 5V$	2.9V +/- 0.1V
Recharge Threshold	$V_{USB} = 5V$	($V_{float} - 130mV$) to ($V_{float} - 60mV$)
USB Current		
I_{USB} - 500mA Mode	$V_{USB} = 5V$, USB Active 500mA Mode	475mA typical, 500mA max
I_{USB} - 100mA Mode	$V_{USB} = 5V$, USB Active 100mA Mode	93mA typical, 100mA max
I_{USB} - Suspend Mode	$V_{USB} = 5V$, USB Suspend	50uA typical , 100uA max

OPERATING PRINCIPLES

DC929A-A is the demo board for LTC4089, while DC929A-B is for LTC4089-5. The only difference is that the voltage on HVOUT/VOUT of LTC4089 tracks battery voltage (0.3V higher than V_{BAT} , with minimum of 3.46V, maximum 4.6V), while that of LTC4089-5 is fixed at 5V. This chip manages the power supplies that would be typical for a USB powered device and/or a high voltage source, such as fire wire or automotive battery. Power

is input from either the USB cable or a high voltage adapter to an intermediate voltage bus VOUT. The intermediate voltage bus is preferentially powered from the adapter, then USB and finally if required from the battery via an internal ideal diode and an optional external MOSFET (Q2). The battery charger is a CC/CV timer terminated type capable of charge currents of up to 1.2A.

QUICK START PROCEDURE

Demonstration circuit DC929A-A/B is easy to set up to evaluate the performance of the LTC4089/-5. Refer to Figure 1 for proper measurement equipment setup and follow the procedure below:

1. Connect input power supply, meters and output load as shown in Figure 1, with the following initial values:

$$PS1 = 0V$$

$$PS2 = 5V$$

$$PS3 = 2.5V$$

$$I_{USB} = 0mA$$

USB Charging

2. Place the USB ON/OFF jumper (JP3) in the ON position. Place the USB Current jumper (JP2) in the 500mA position. Turn on the power supplies, the charger should activate and the charge LED D4 will illuminate. The battery will be in trickle charge mode, I_{BAT} is around 70mA. Increase the battery voltage to above 2.9V the battery charge current (I_{BAT}) will increase to 470mA. Note that the input current from the USB (I_{USB}) is about 475mA, which does not exceed the USB spec of 500mA.
3. Now increase the load on the SYSTEM LOAD OUTPUT (I_{OUT}). Note that as the output load is increased the charging current is decreased and the USB current remains within the 500mA limit.
4. Place the USB current jumper in the 100mA position and note that USB input current falls to maintain compliance with the USB input current spec. Also note that as the external load is increased the battery will start to discharge into the SYSTEM LOAD OUTPUT, illustrating the ideal diode function of the LTC4089
5. Place the USB ON/OFF jumper (JP1) in the OFF position and note that the USB current falls to under 100uA to comply with the USB suspend mode current.

Adapter Charging

6. Ramp up the wall adapter voltage. When the wall adapter exceeds 5.9 volts the LTC4089 will cease drawing current from the USB and switch over to the wall adapter. Both the AC-present LED (D3, red) and charge LED (D4, green) are on.
7. Note that the V_{OUT} of DC929A-A is about 0.3V above V_{BAT} , indicating the adaptive feature of V_{OUT} to minimize the charging power loss. The V_{OUT} of DC929A-B is fixed at 5V.
8. Note that the charge current to the battery has increased to 700mA.
9. Increase the battery voltage to 4.2V and note that the charge current falls to 0. This illustrates the constant voltage portion of the charging characteristic. In the mean time, the charge LED (D4) turns off.

Battery Powered Operation

10. Set Both USB input voltage and the adapter input voltage to zero. The battery will now power the load on the System Load Output, illustrating the ideal diode function of the LTC4085. Note that the battery is now being discharged.

Other

Frequency at charge timer cap C4 changes with charging current, indicating the adaptive feature to ensure the full charge of battery.

11. Pins are provided to all control functions in order to simplify wiring of the demo circuit into a system board.
12. NTC function; provision has been made for connection of an external 10k NTC, for temperature qualified charging. To use this feature set the NTC jumper in the external position and connect the external NTC to the NTC terminal and ground.

QUICK START GUIDE FOR DEMONSTRATION CIRCUIT DC929A-A/B USB POWER SOLUTION IN DFN 6X3

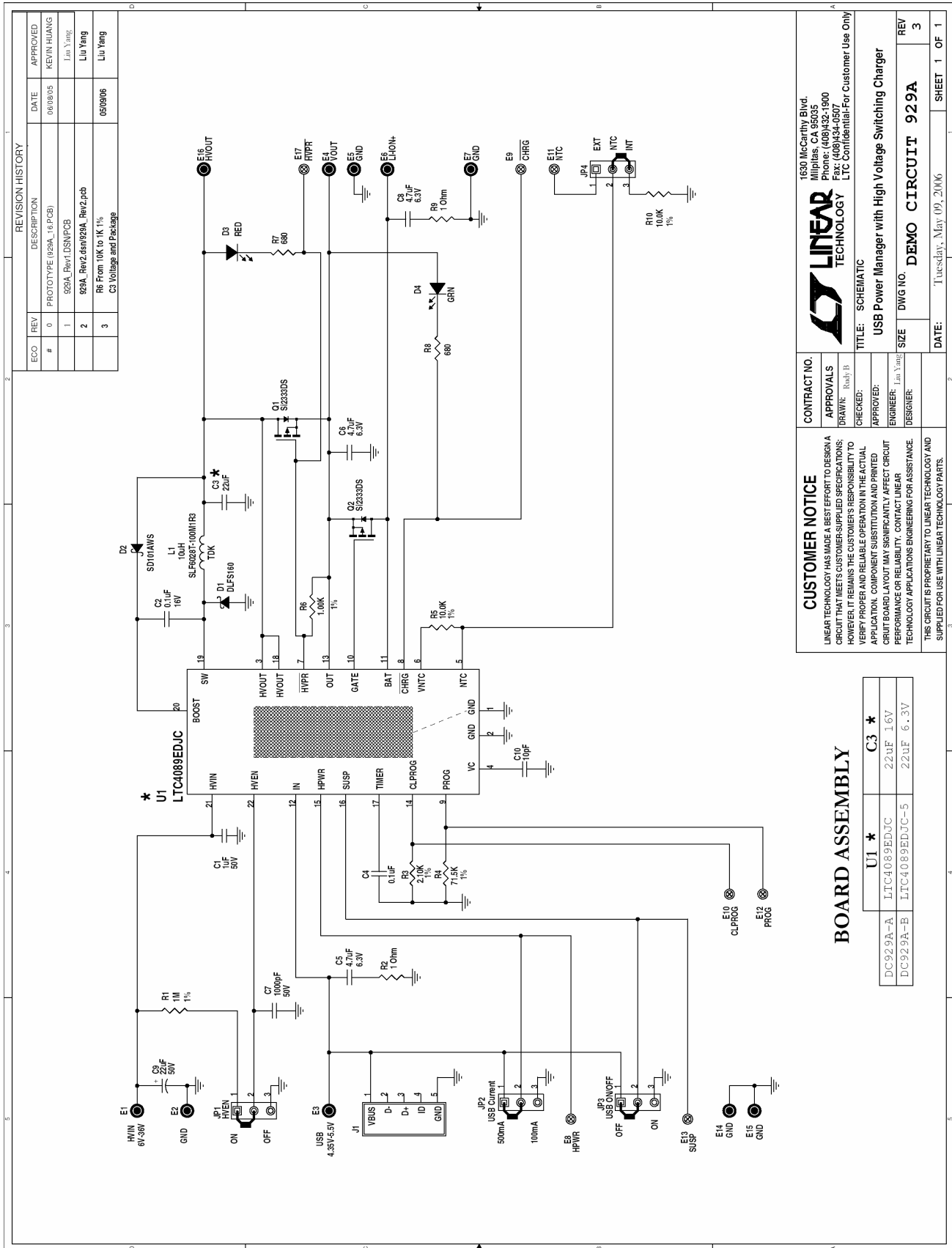

QUICK START GUIDE FOR DEMONSTRATION CIRCUIT DC929A-A/B

USB POWER SOLUTION IN DFN 6X3

DEMO CIRCUIT 929A-A				
REQUIRED CIRCUIT COMPONENTS				
1	1	C1	Cap., X5R 1uF 50V 20%	TDK C3216X5R1H105M
2	2	C2,C4	Cap., X5R 0.1uF 10V 10%	AVX 0402ZD104KAT2A
3	1	C3	Cap., X5R 22uF 16V 20%	Taiyo Yuden EMK316BJ226ML
4	2	C5,C6	Cap., X5R 4.7uF 6.3V 20%	TDK C1608X5R0J475M
5	1	C10	Cap., NPO 10pF 25V 10%	AVX 04023A100KAT2A
6	1	D1	Schottky Rect., 60V/1Amp	DIODES INC. DLFS160-7
7	1	D2	Schottky Diode, 60V/15mA	DIODES Inc. SD101AWS-7
8	1	L1	Inductor, 10uH	TDK SLF6028T-100M1R3
9	1	Q1	Mosfet P-Chan., 12V	Vishay Siliconix Si2333DS
10	1	R2	Res., Chip 1 Ohm 0.06W 5%	AAC CR05-1R0JM
11	1	R3	Res., Chip 2.10K 1/16W 1%	AAC CR05-2101FM
12	1	R4	Res., Chip 71.5K 0.06W 1%	AAC CR05-7152FM
13	1	R5	Res., Chip 10.0K 0.06W 1%	AAC CR05-1002FM
14	1	R6	Res., Chip 1.00K 0.06W 1%	AAC CR05-1001FM
15	1	U1	I.C., Volt. Reg.	Linear Tech. Corp. LTC4089EDJC#PBF
ADDITIONAL DEMO BOARD CIRCUIT COMPONENTS				
1	1	C7	Cap., X7R 1000pF 50V 10%	AVX 04025C102KAT2A
2	1	C8	Cap., X5R 4.7uF 6.3V 20%	TDK C1608X5R0J475M
3	1	C9	Cap., Alum 22uF 50V 10%	OSCON 50CV22BS
4	1	D3	LED, RED	Panasonic LN1251-C-TR
5	1	D4	LED, GRN	Panasonic LN1351-C-TR
6	1	Q2	Mosfet P-Chan., 12V	Vishay Siliconix Si2333DS
7	1	R1	Res., Chip 1M 0.06W 1%	AAC CR05-1004FM
8	2	R7,R8	Res., Chip 680 0.06W 5%	AAC CR05-681JM
9	1	R9	Res., Chip 1 Ohm 0.06W 5%	AAC CR05-1R0JM
10	1	R10	Res., Chip 10.0K 0.06W 1%	AAC CR05-1002FM
HARDWARE FOR DEMO BOARD ONLY				
1	10	E1-E7,E14-E16	Turret, Testpoint	Mill Max 2501-2
2	7	E8-E13,E17	Turret, Testpoint	Mill Max 2308-2
3	4	JP1,JP2,JP3,JP4	Headers, 3 Pins 2mm Ctrs.	CommConn Con Inc. 2802S-03G2
4	1	J1	Connector, USB Mini-A	Tyco Electronics 440247-1
5	4	XJP1,XJP2,XJP3,XJP4	Shunt, 2mm Ctrs.	CommConn Con Inc. CCIJ2MM-138G

QUICK START GUIDE FOR DEMONSTRATION CIRCUIT DC929A-A/B

USB POWER SOLUTION IN DFN 6X3

DEMO CIRCUIT 929A-B				
REQUIRED CIRCUIT COMPONENTS				
1	1	C1	Cap., X5R 1uF 50V 20%	TDK C3216X5R1H105M
2	2	C2,C4	Cap., X5R 0.1uF 10V 10%	AVX 0402ZD104KAT2A
3	1	C3	Cap., X5R 22uF 6.3V 20%	TDK C2012X5R0J226M
4	2	C5,C6	Cap., X5R 4.7uF 6.3V 20%	TDK C1608X5R0J475M
5	1	C10	Cap., NPO 10pF 25V 10%	AVX 04023A100KAT2A
6	1	D1	Schottky Rect., 60V/1Amp	DIODES INC. DLFS160-7
7	1	D2	Schottky Diode, 60V/15mA	DIODES Inc. SD101AWS-7
8	1	L1	Inductor, 10uH	TDK SLF6028T-100M1R3
9	1	Q1	Mosfet P-Chan., 12V	Vishay Siliconix Si2333DS
10	1	R2	Res., Chip 1 Ohm 0.06W 5%	AAC CR05-1R0JM
11	1	R3	Res., Chip 2.10K 1/16W 1%	AAC CR05-2101FM
12	1	R4	Res., Chip 71.5K 0.06W 1%	AAC CR05-7152FM
13	1	R5	Res., Chip 10.0K 0.06W 1%	AAC CR05-1002FM
14	1	R6	Res., Chip 1.00K 0.06W 1%	AAC CR05-1001FM
15	1	U1	I.C., Volt. Reg.	Linear Tech. Corp. LTC4089EDJC-5#PBF
ADDITIONAL DEMO BOARD CIRCUIT COMPONENTS				
1	1	C7	Cap., X7R 1000pF 50V 10%	AVX 04025C102KAT2A
2	1	C8	Cap., X5R 4.7uF 6.3V 20%	TDK C1608X5R0J475M
3	1	C9	Cap., Alum 22uF 50V 10%	OSCON 50CV22BS
4	1	D3	LED, RED	Panasonic LN1251-C-TR
5	1	D4	LED, GRN	Panasonic LN1351-C-TR
6	1	Q2	Mosfet P-Chan., 12V	Vishay Siliconix Si2333DS
7	1	R1	Res., Chip 1M 0.06W 1%	AAC CR05-1004FM
8	2	R7,R8	Res., Chip 680 0.06W 5%	AAC CR05-681JM
9	1	R9	Res., Chip 1 Ohm 0.06W 5%	AAC CR05-1R0JM
10	1	R10	Res., Chip 10.0K 0.06W 1%	AAC CR05-1002FM
HARDWARE FOR DEMO BOARD ONLY				
1	10	E1-E7,E14-E16	Turret, Testpoint	Mill Max 2501-2
2	7	E8-E13,E17	Turret, Testpoint	Mill Max 2308-2
3	4	JP1,JP2,JP3,JP4	Headers, 3 Pins 2mm Ctrs.	CommConn Con Inc. 2802S-03G2
4	1	J1	Connector, USB Mini-A	Tyco Electronics 440247-1
5	4	XJP1,XJP2,XJP3,XJP4	Shunt, 2mm Ctrs.	CommConn Con Inc. CCIJ2MM-138G

X-ON Electronics

Largest Supplier of Electrical and Electronic Components

Click to view similar products for [Power Management IC Development Tools](#) category:

Click to view products by [Analog Devices](#) manufacturer:

Other Similar products are found below :

[EVAL-ADM1168LQEBZ](#) [EVB-EP5348UI](#) [MIC23451-AAAYFL EV](#) [MIC5281YMME EV](#) [DA9063-EVAL](#) [ADP122-3.3-EVALZ](#) [ADP130-0.8-EVALZ](#) [ADP130-1.2-EVALZ](#) [ADP130-1.5-EVALZ](#) [ADP130-1.8-EVALZ](#) [ADP1714-3.3-EVALZ](#) [ADP1716-2.5-EVALZ](#) [ADP1740-1.5-EVALZ](#) [ADP1752-1.5-EVALZ](#) [ADP1828LC-EVALZ](#) [ADP1870-0.3-EVALZ](#) [ADP1871-0.6-EVALZ](#) [ADP1873-0.6-EVALZ](#) [ADP1874-0.3-EVALZ](#) [ADP1882-1.0-EVALZ](#) [ADP199CB-EVALZ](#) [ADP2102-1.25-EVALZ](#) [ADP2102-1.875EVALZ](#) [ADP2102-1.8-EVALZ](#) [ADP2102-2-EVALZ](#) [ADP2102-3-EVALZ](#) [ADP2102-4-EVALZ](#) [ADP2106-1.8-EVALZ](#) [ADP2147CB-110EVALZ](#) [AS3606-DB](#) [BQ24010EVM](#) [BQ24075TEVM](#) [BQ24155EVM](#) [BQ24157EVM-697](#) [BQ24160EVM-742](#) [BQ24296MEVM-655](#) [BQ25010EVM](#) [BQ3055EVM](#) [NCV891330PD50GEVB](#) [ISLUSBI2CKIT1Z](#) [LM2744EVAL](#) [LM2854EVAL](#) [LM3658SD-AEV/NOPB](#) [LM3658SDEV/NOPB](#) [LM3691TL-1.8EV/NOPB](#) [LM4510SDEV/NOPB](#) [LM5033SD-EVAL](#) [LP38512TS-1.8EV](#) [EVAL-ADM1186-1MBZ](#) [EVAL-ADM1186-2MBZ](#)