

## DESCRIPTION

Demonstration circuit 975A is a DC/DC Converter for APD Bias featuring the LT3482 in a 3mm x 3mm QFN package. This demo circuit is designed to convert a 3V-12V source to 80V at 2mA. The circuit runs at 1.1MHz but can be easily programmed to run at 650KHz (inductor and other components might need to change for such case). The LT3482 features a 48V, 260mA switch, integrated Schottky diodes and a high side current monitor which provides a current proportional to the APD current. This current can be used as a reference to digitally program the output via the CTRL pin.

This circuit is specifically designed for APD bias and is optimized for performance, solution size and profile. To further reduce the solution size, inductors such as Taiyo Yuden BRL2012B type can be used though efficiency will suffer about 10%. Typical applications include APD bias, PIN Diode Bias, Optical Receivers and Modules, Fiber Optic Network Equipment etc.

**Design files for this circuit board are available. Call the LTC factory.**

LT is a registered trademark of Linear Technology Corporation.

## PERFORMANCE SUMMARY DC975A Specifications are at TA = 25°C

SYMBOL	PARAMETER	CONDITIONS	MIN	TYP	MAX	UNITS
V <sub>IN</sub>	Input Supply Range		3		12	V
V <sub>OUT</sub>	Output Voltage Range	V <sub>IN</sub> = 3V, I <sub>LOAD</sub> = 2mA	75	80	85	V
V <sub>OUT</sub>	Output Voltage Range	V <sub>IN</sub> = 12V, I <sub>LOAD</sub> = 2mA	75	80	85	V
RIPPLE		V <sub>IN</sub> = 3.6V, I <sub>LOAD</sub> = 2mA		500		μV
FS	Switching frequency			1.1		MHz

## QUICK START PROCEDURE

Demonstration circuit 975 is easy to set up to evaluate the performance of the LT3482. Refer to Figure 1. for proper measurement equipment setup and follow the procedure below:

**NOTE.** When measuring the output voltage ripple, use a BNC cable to connect J1 to the oscilloscope. Set the oscilloscope to AC couple, 2mV/division. That should yield the results shown in Figure 2 (Make sure there are no test cables connected to the APD node).

1. Place jumper in the following position:

**JP1** Run

2. With power off, connect the input power supply to Vin and GND.

3. Connect a 40K resistor from APD to GND.

4. Turn on the power at the input.

5. Check for the proper output voltage. Vout1 = 75V to 85V.

**NOTE.** If there is no output, temporarily disconnect the load to make sure that the load is not set too high.

6. Once the proper output voltage is established, adjust the load within the operating range and observe the output voltage regulation, ripple voltage, efficiency and other parameters.

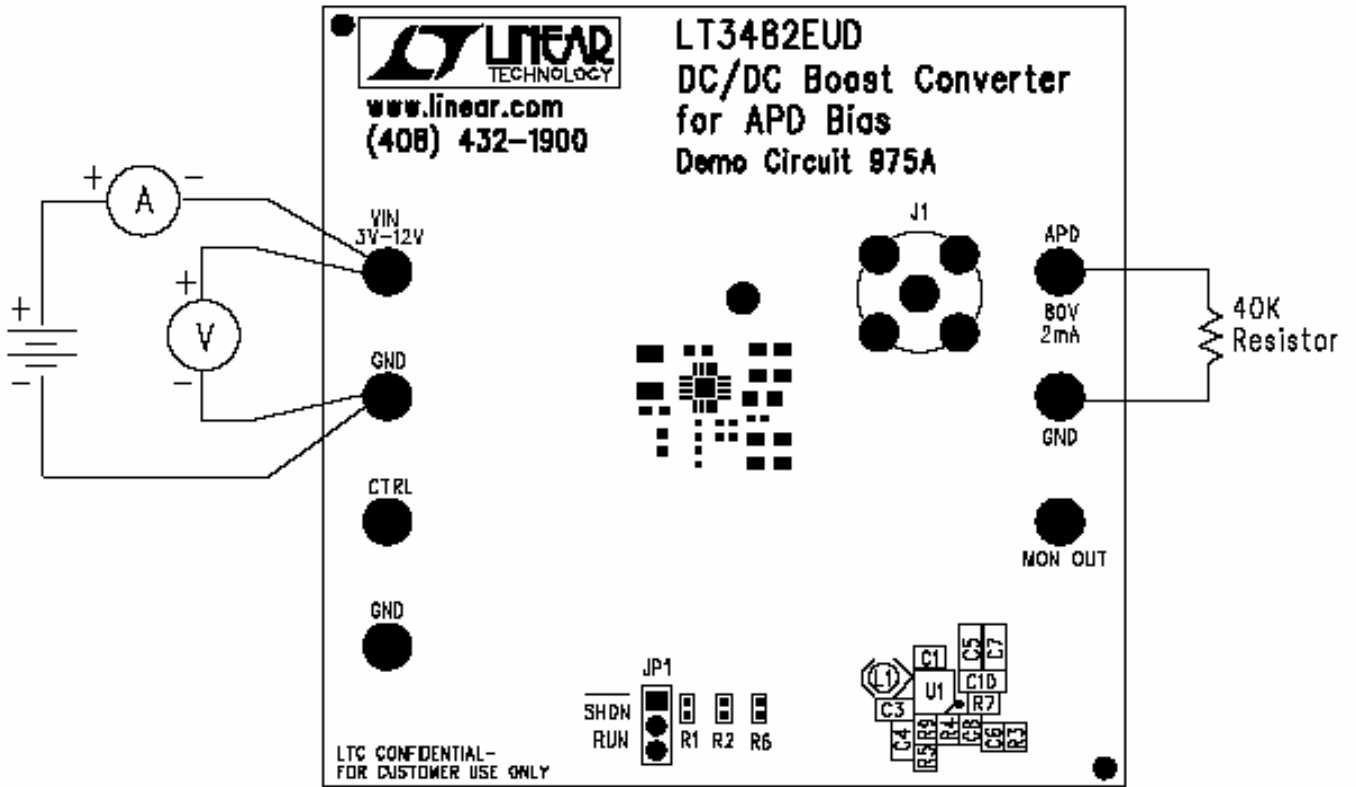

Figure 1. Proper Measurement Equipment Setup

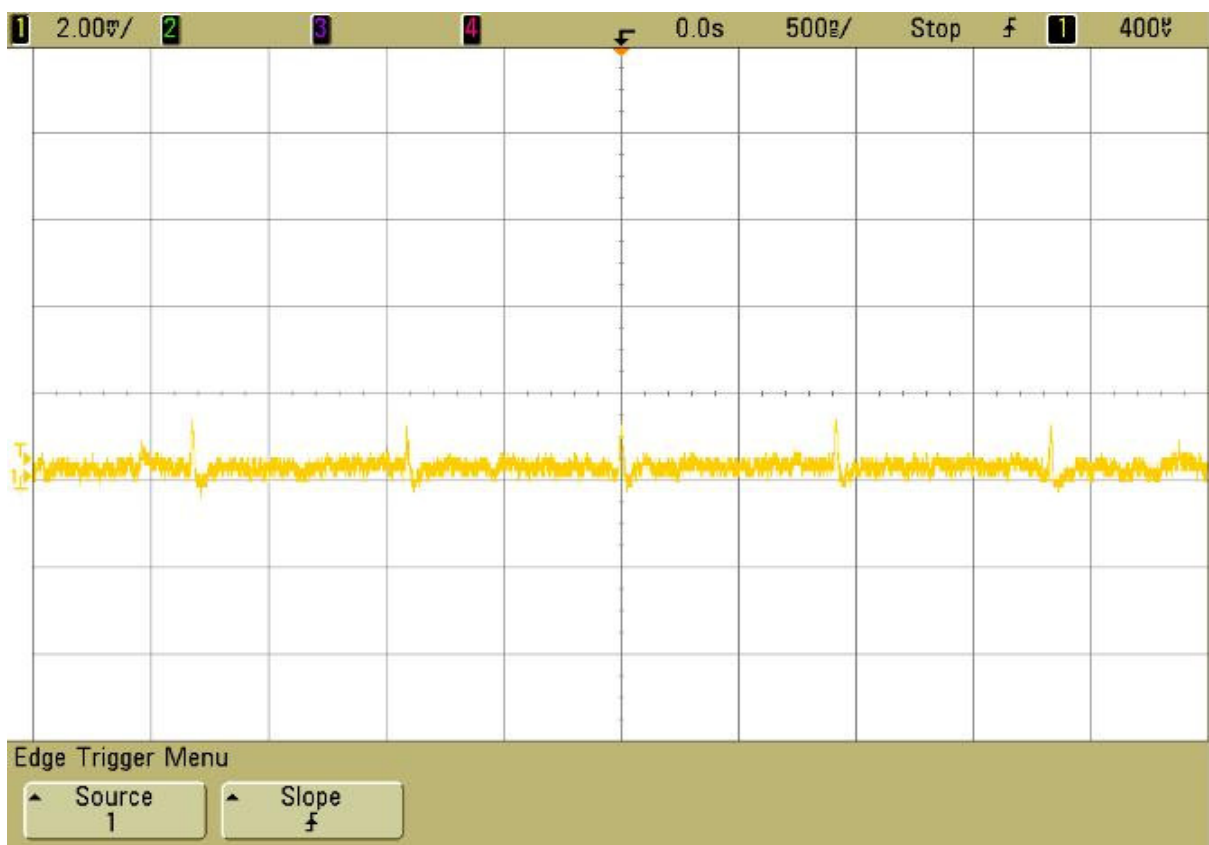
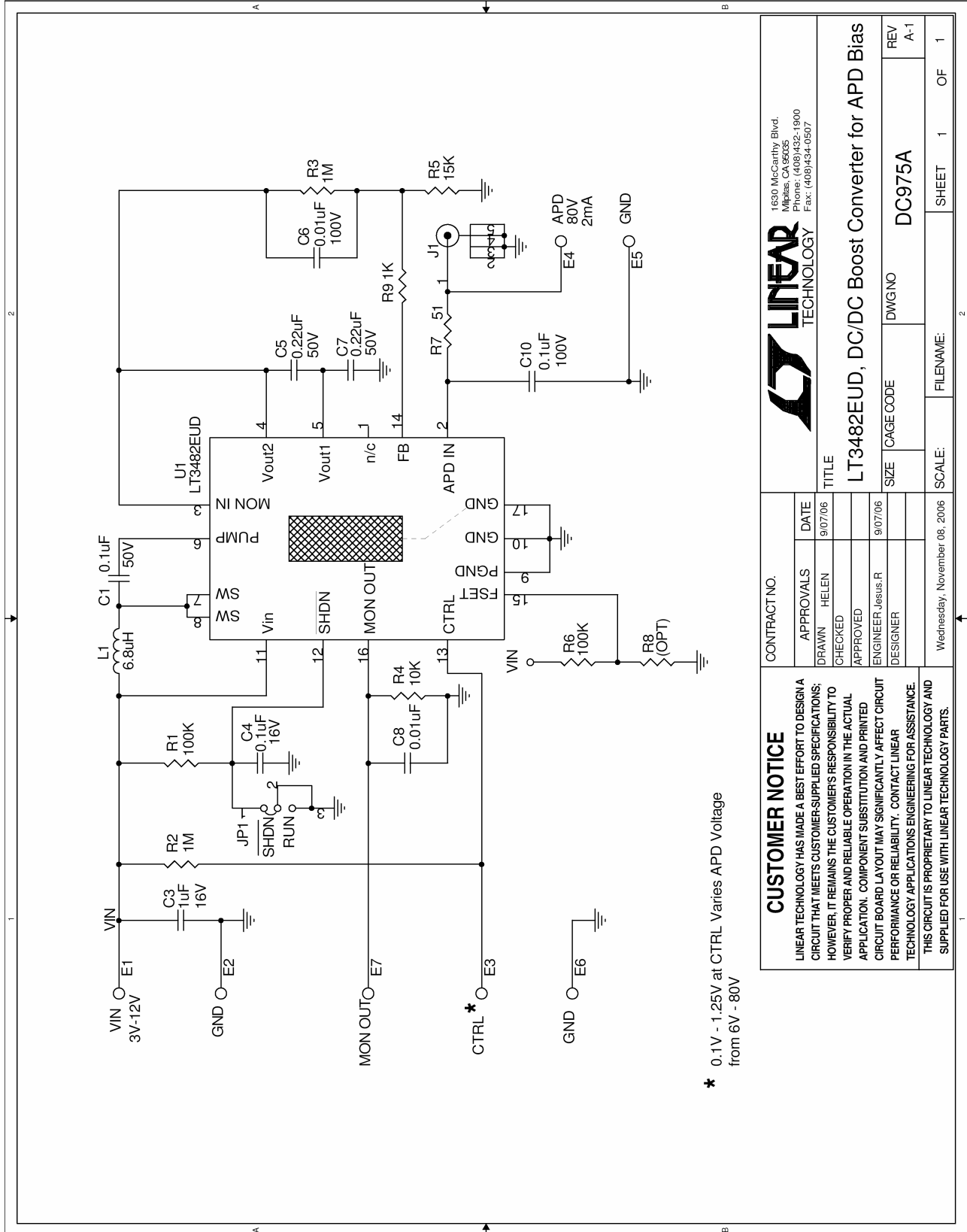

Figure 2. Output Ripple measured with BNC cable directly connected to oscilloscope. BW=20MHz. 2mV/div



<b>CUSTOMER NOTICE</b>		<b>CONTRACT NO.</b>					
LINEAR TECHNOLOGY HAS MADE A BEST EFFORT TO DESIGN A CIRCUIT THAT MEETS CUSTOMER-SUPPLIED SPECIFICATIONS; HOWEVER, IT REMAINS THE CUSTOMER'S RESPONSIBILITY TO VERIFY PROPER AND RELIABLE OPERATION IN THE ACTUAL APPLICATION. COMPONENT SUBSTITUTION AND PRINTED CIRCUIT BOARD LAYOUT MAY SIGNIFICANTLY AFFECT CIRCUIT PERFORMANCE OR RELIABILITY. CONTACT LINEAR TECHNOLOGY APPLICATIONS ENGINEERING FOR ASSISTANCE. THIS CIRCUIT IS PROPRIETARY TO LINEAR TECHNOLOGY AND SUPPLIED FOR USE WITH LINEAR TECHNOLOGY PARTS.							
APPROVALS	DATE	1630 McCarthy Blvd. Milpitas, CA 95035 Phone: (408)432-1900 Fax: (408)434-0507					
DRAWN HELEN	9/07/06	<b>LINEAR TECHNOLOGY</b>					
CHECKED							
APPROVED		TITLE <b>LT3482EUD, DC/DC Boost Converter for APD Bias</b>					
ENGINEER Jesus.R	9/07/06						
DESIGNER		SIZE	CAGE CODE	DWGNO	DC975A	REV	A-1
Wednesday, November 08, 2006	SCALE:	FILENAME:	SHEET	1	OF	1	

Item	Qty	Reference	Part Description	Manufacturer / Part #
<b>REQUIRED CIRCUIT COMPONENTS:</b>				
1	1	C1	CAP., X7R, 0.1uF, 50V, 10%, 0603	TDK, C1608X7R1H104K
2	1	C3	CAP., X7R, 1uF, 16V, 20%, 0603	TDK, C1608X7R1C105M
3	1	C4	CAP., X7R, 0.1uF, 16V, 10%, 0603	AVX, 0603YC104KAT2A
4	2	C5,C7	CAP., X7R, 0.22uF, 50V, 10%, 0805	TAIYO YUDEN, UMK212BJ224MG
5	1	C6	CAP., X7R, 0.01uF, 100V, 10%, 0805	AVX, 08051C103KAT
6	1	C8	CAP., X7R, 0.01uF, 16V, 20%, 0402	AVX, 0402YC103MAT2A
7	1	C10	CAP., X7R, 0.1uF, 100V, 20%, 0805	TDK, C2012X7R2A104M
8	1	L1	INDUCTOR., 6.8uH	COILTRONICS, SD3110-6R8-R
9	2	R1,R6	RES., CHIP, 100K, 1/16W, 5%, 0402	VISHAY, CRCW0402104JRT6
10	1	R2	RES., CHIP, 1M, 1/16W, 1%, 0402	VISHAY, CRCW04021004FRT6
11	1	R3	RES., CHIP, 1M, 1/10W, 1%, 0805	VISHAY, CRCW08051004FRT6
12	1	R4	RES., CHIP, 10K, 1/16W, 1%, 0402	VISHAY, CRCW040210K0FKED
13	1	R5	RES., CHIP, 15.8K, 1/16W, 1%, 0402	VISHAY, CRCW040215K8FKED
14	1	R7	RES., CHIP, 51, 1/16W, 5%, 0402	VISHAY, CRCW040251R0JNED
15	1	R9	RES., CHIP, 1K, 1/16W, 5%, 0402	VISHAY, CRCW04021K00JNED
16	1	U1	I.C., LT3482EUD#PBF, 3X3mm, QFN	LINEAR TECH, LT3482EUD#PBF
<b>ADDITIONAL DEMO BOARD CIRCUIT COMPONENTS:</b>				
1	1	R8(OPT)	RES., 0402	
<b>HARDWARE-FOR DEMO BOARD ONLY:</b>				
1	7	E1-E7	TESTPOINT, TURRET, .095"	MILL-MAX, 2501-2-00-80-00-00-70-0
2	1	J1	CONN, BNC, 5PINS	CONNEX, 112404
3	1	JP1	0.079 SINGLE ROW HEADER, 3 PIN	SAMTEC, TMM-103-02-L-S
4	1	JP1	SHUNT	SAMTEC, 2SN-BK-G

## X-ON Electronics

Largest Supplier of Electrical and Electronic Components

*Click to view similar products for [Power Management IC Development Tools](#) category:*

*Click to view products by [Analog Devices](#) manufacturer:*

Other Similar products are found below :

[EVAL-ADM1168LQEBZ](#) [EVB-EP5348UI](#) [MIC23451-AAAYFL EV](#) [MIC5281YMME EV](#) [DA9063-EVAL](#) [ADP122-3.3-EVALZ](#) [ADP130-0.8-EVALZ](#) [ADP130-1.2-EVALZ](#) [ADP130-1.5-EVALZ](#) [ADP130-1.8-EVALZ](#) [ADP1714-3.3-EVALZ](#) [ADP1716-2.5-EVALZ](#) [ADP1740-1.5-EVALZ](#) [ADP1752-1.5-EVALZ](#) [ADP1828LC-EVALZ](#) [ADP1870-0.3-EVALZ](#) [ADP1871-0.6-EVALZ](#) [ADP1873-0.6-EVALZ](#) [ADP1874-0.3-EVALZ](#) [ADP1882-1.0-EVALZ](#) [ADP199CB-EVALZ](#) [ADP2102-1.25-EVALZ](#) [ADP2102-1.875EVALZ](#) [ADP2102-1.8-EVALZ](#) [ADP2102-2-EVALZ](#) [ADP2102-3-EVALZ](#) [ADP2102-4-EVALZ](#) [ADP2106-1.8-EVALZ](#) [ADP2147CB-110EVALZ](#) [AS3606-DB](#) [BQ24010EVM](#) [BQ24075TEVM](#) [BQ24155EVM](#) [BQ24157EVM-697](#) [BQ24160EVM-742](#) [BQ24296MEVM-655](#) [BQ25010EVM](#) [BQ3055EVM](#) [NCV891330PD50GEVB](#) [ISLUSBI2CKIT1Z](#) [LM2744EVAL](#) [LM2854EVAL](#) [LM3658SD-AEV/NOPB](#) [LM3658SDEV/NOPB](#) [LM3691TL-1.8EV/NOPB](#) [LM4510SDEV/NOPB](#) [LM5033SD-EVAL](#) [LP38512TS-1.8EV](#) [EVAL-ADM1186-1MBZ](#) [EVAL-ADM1186-2MBZ](#)