

QUICK START GUIDE FOR DC989B-A

TINY NO R_{SENSE} BOOST CONVERTER

LTC3872

DESCRIPTION

Demonstration circuit 989B-A is a single-output boost converter, it features tiny, boost controller LTC3872. The input voltage is from 3.0V to 4.5V without output de-rating. The supply has one output: 5V/2A_{MAX}. Minimum input voltage is 2.75V. When input voltage is lower than 3V, output current should be de-rated. The design employs the LTC3872, the small footprint NO R_{SENSE} boost regulator. The switching frequency is fixed at 550 kHz. With current mode control and OPTI-LOOP compensation, DC989B-A can be optimized to provide fast transient response. NO R_{SENSE} technique reduces both: size of the converter and power dissipation. However, care should be taken

to MOSFET selection, it's not only switching element, but also its R_{DS(ON)} represents the current sensing element for the control loop, see LTC3872 datasheet for details. LTC3872 allows design small size and high efficiency step-up DC/DC solutions.

Design files for this circuit board are available. Call the LTC factory.

TM-NO R_{SENSE} is trademark of Linear Technology Corporation

Table 1. Performance Summary (T_A = 25°C)

PARAMETER	CONDITION	VALUE
Minimum Input Voltage	If the input voltage must be lower than 3V, degrade output load current.	2.75V
Maximum Input Voltage		4.5V
Output Voltage V _{OUT}		5V +/- 2%
Maximum Continuous output Current	V _{IN} = 3V to 4.5V	2A
Typical Operating Frequency	Fixed	550kHz
Typical Output Ripple (V _{OUT})	20MHz BW, 2A load, V _{IN} = 3V, frequency = 550kHz	30mV _{P-P}
Efficiency	V _{IN} =3V, V _{OUT} =5V I _{OUT} =2A	90%

QUICK START PROCEDURE

Demonstration circuit 989B-A is easy to set up to evaluate the performance of the LTC3872. Please refer to Figure 1 for proper measurement equipment setup and follow the procedure below:

1. Place RUN in ON position for normal operation.

Connect the desired loads between 5V output terminal and the GND terminal on the board.

NOTE: The maximum load is 2A.

2. Connect the input power supply to the VIN and GND terminals on the right, center of the board.

NOTE: Do not increase V_{IN} over 5V.

3. Vary the input voltage from 3.0V to 4.5V and adjust the load current from 0 to 2A. Measure the output voltages. V_{OUT} should read between 5.0V ±0.1V within specified maximum load current.
4. Measure the output ripple voltage at maximum output current level and minimum in-

QUICK START GUIDE FOR DC989B-A

TINY NO R_{SENSE} BOOST CONVERTER

put voltage; it usually will measure less than 30mV.

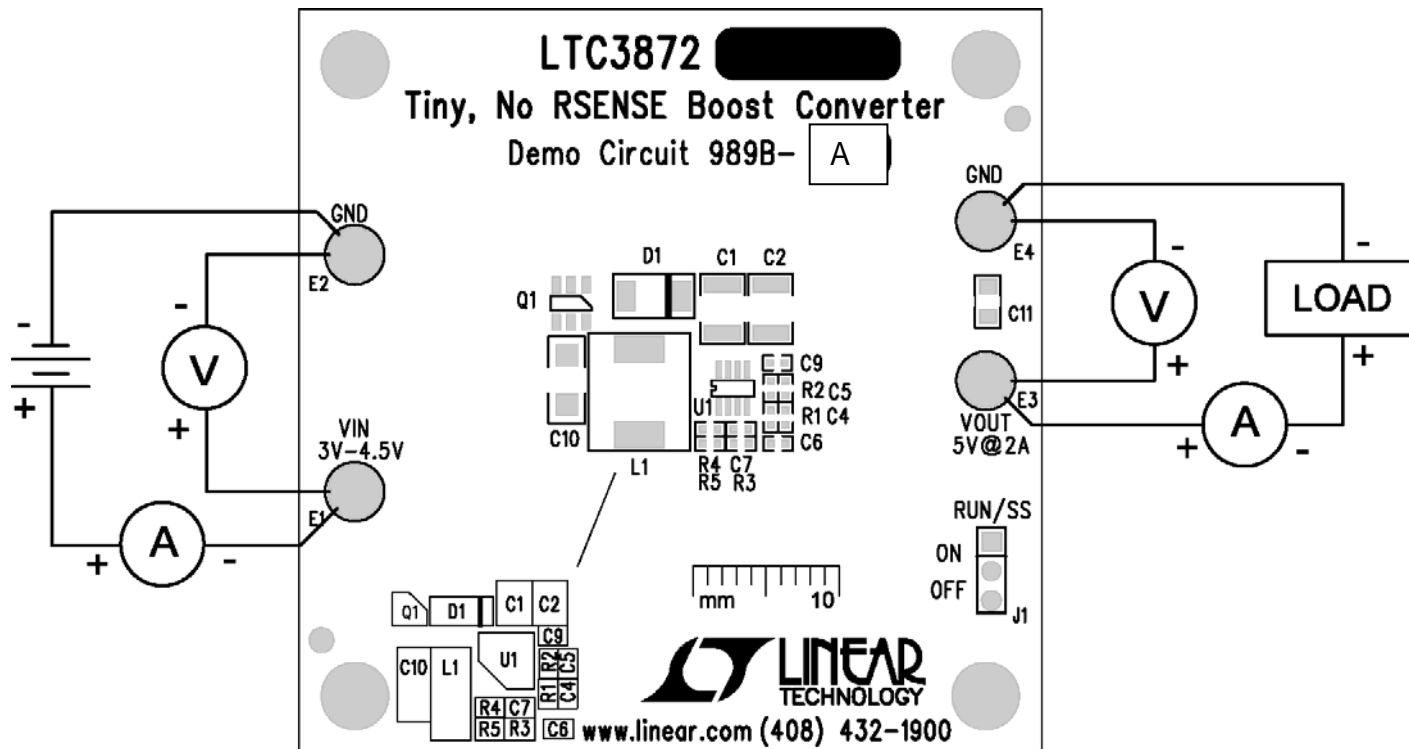

Figure 1. Proper Measurement Equipment Setup

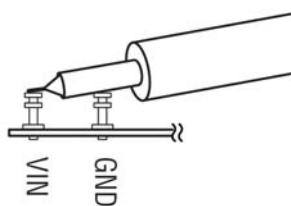

Figure 2. Scope Probe Placements for Measuring Input or Output Ripple.

QUICK START GUIDE FOR DC989B-A

TINY NO R_{SENSE} BOOST CONVERTER

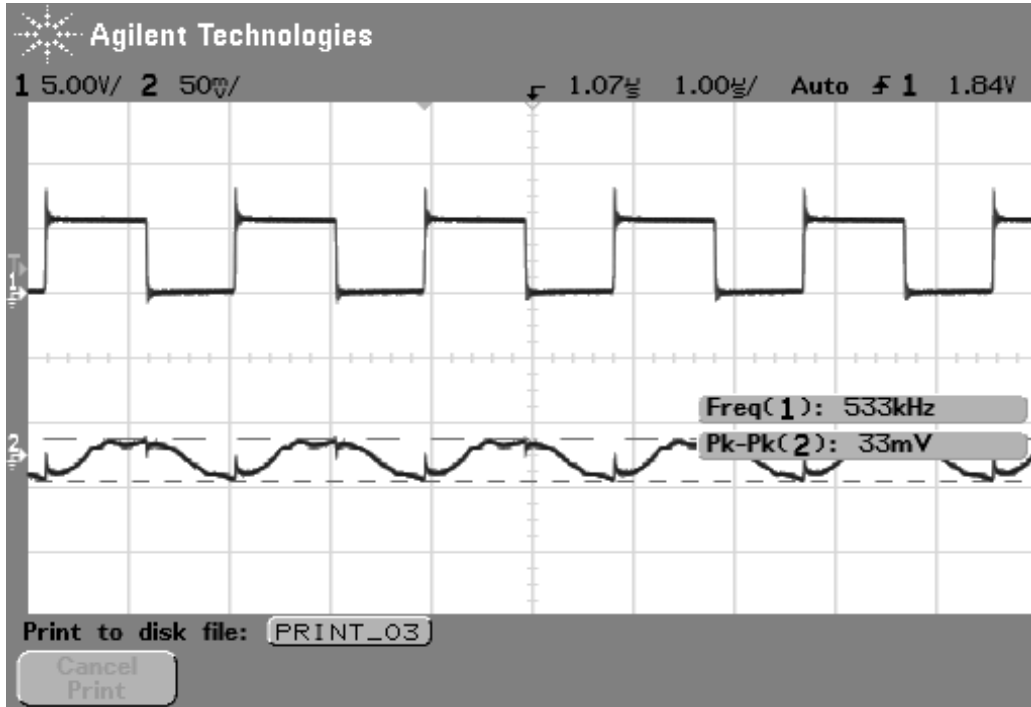

Figure 3. Typical Switch Node and Output Ripple Waveform

$V_{IN}=3.0V, V_{OUT}=5V, I_{OUT}=2A$

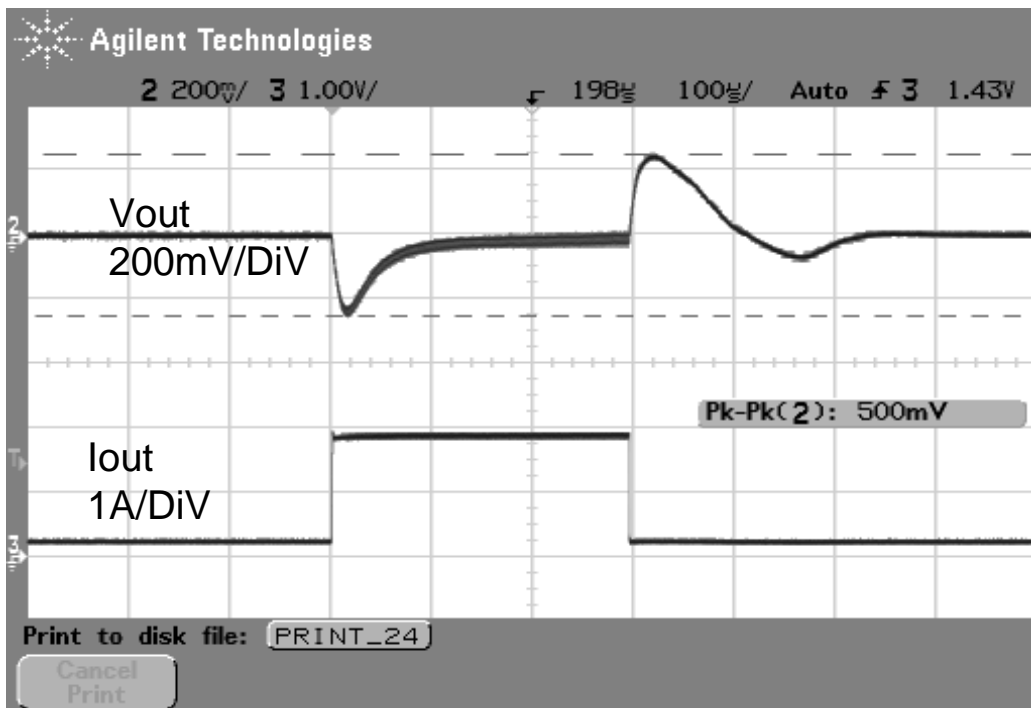
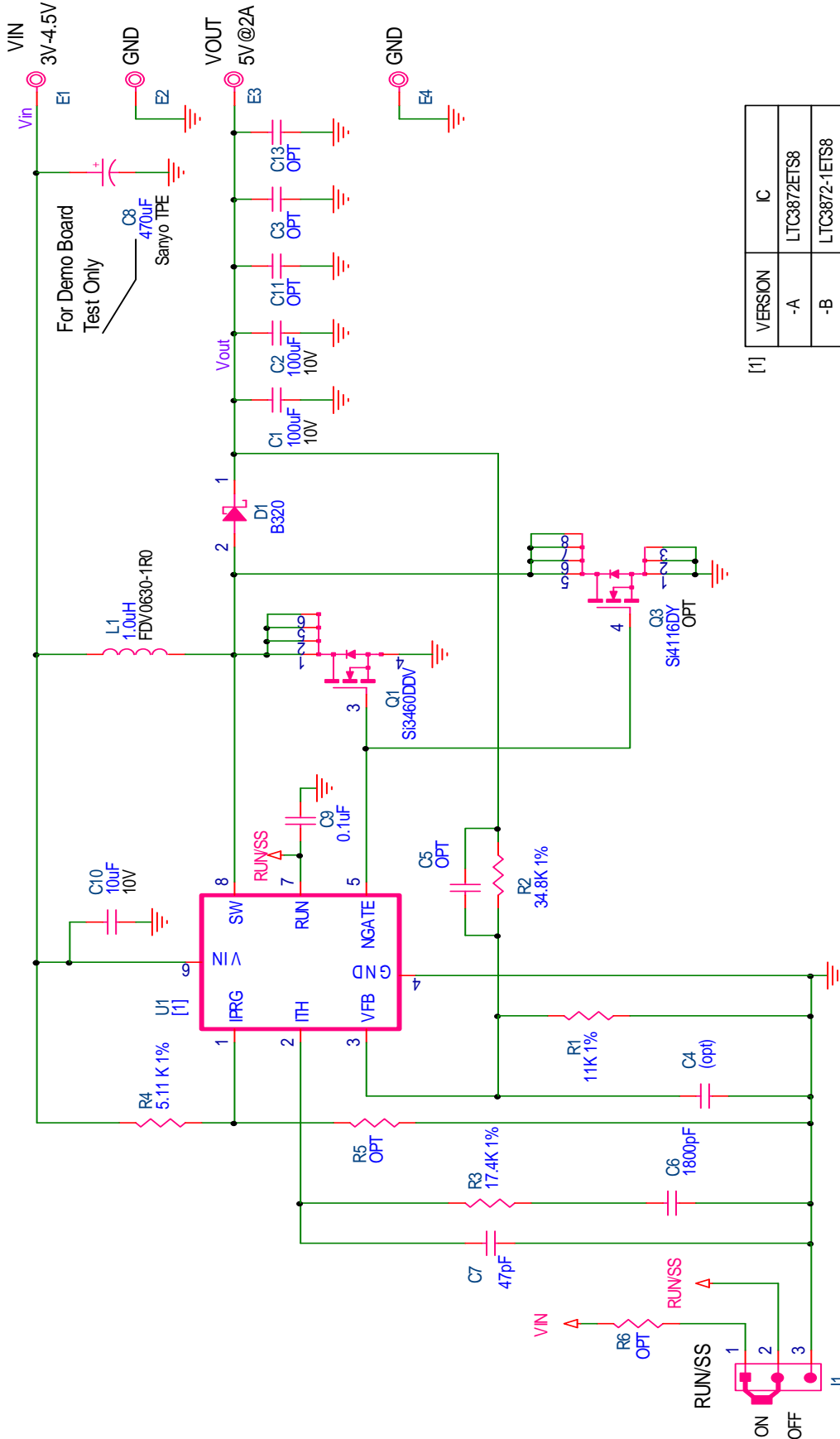

Figure 4. Load Step Response

$V_{IN} = 3.3V, V_{OUT} = 5V$ & 1.6A Load Step

QUICK START GUIDE FOR DC989B-A

TINY NO R_{SENSE} BOOST CONVERTER



VERSION	IC
-A	LTC3872ETS8
-B	LTC3872-1ETS8

[1]

QUICK START GUIDE FOR DC989B-A

TINY NO R_{SENSE} BOOST CONVERTER

Item	Qty	Ref-Des	Part Description	Manufacturer's Part Number
REQUIRED CIRCUIT COMPONENTS:				
1	2	C1,C2	CAP 1210 100uF 20% 10V X5R	TAIYO YUDEN LMK325ABJ107MM-T
2	1	C6	CAP 0402 1800pF 5% 50V X7R	AVX 04025C182JAT
3	1	C7	CAP 0402 47pF 5% 25V NPO	AVX 0603YC104KAT
4	1	C8	CAP 7343 470uF 20% 6.3V POSCAP	SANYO 6TPE470M
5	1	C9	CAP 0402 0.1uF 10% 16V X5R	TDK C1005X5R1C104K
6	1	C10	CAP1206 10uF 10% 10V X5R	TAIYO YUDEN LMK316BJ106KD-T
7	1	D1	DIODE, B320A-13	DIODES INC. B320A-13
8	1	L1	IND 1.0uH	TOYO FDV0630-1R0M-P3
9	1	Q1	XSTR MOSFET N-CHANNEL 20v	VISHAY SI3460DDV
10	1	R1	RES 0402 11k OHMS 1% 1/16W	VISHAY CRCW040211K0FKED
11	1	R2	RES 0402 34.8k OHMS 1% 1/16W	VISHAY CRCW040234K8FKED
12	1	R3	RES 0402 17.4k OHMS 1% 1/10W	VISHAY CRCW040217K4FKED
13	1	R4	RES 0402 5.11k OHMS 1% 1/16W	VISHAY CRCW04025K11FKED
14	1	U1	IC, CURRENT MODE BOOST DC/DC CONTROLLER	LINEAR TECH. LTC3872ETS8#TRPBF
ADDITIONAL DEMO BOARD CIRCUIT COMPONENTS:				
1		C3,C4,C5,C11,C13		OPT
2		Q3		VISHAY SI4116DY OPTION
3		R5,R6		OPT
HARDWARE				
1	4	E1,E2,E3,E4	TURRET	MILL MAX 2501-2-00-80-00-00-07-0
2	1	J1	HEADER 3PIN 2mm	SULLINS NRPN031PAEN-RC
3	1	JP1	SHUNT	SAMTEC 2SN-BK-C

X-ON Electronics

Largest Supplier of Electrical and Electronic Components

Click to view similar products for [Power Management IC Development Tools](#) category:

Click to view products by [Analog Devices](#) manufacturer:

Other Similar products are found below :

[EVAL-ADM1168LQEBZ](#) [EVB-EP5348UI](#) [MIC23451-AAAYFL EV](#) [MIC5281YMME EV](#) [DA9063-EVAL](#) [ADP122-3.3-EVALZ](#) [ADP130-0.8-EVALZ](#) [ADP130-1.2-EVALZ](#) [ADP130-1.5-EVALZ](#) [ADP130-1.8-EVALZ](#) [ADP1714-3.3-EVALZ](#) [ADP1716-2.5-EVALZ](#) [ADP1740-1.5-EVALZ](#) [ADP1752-1.5-EVALZ](#) [ADP1828LC-EVALZ](#) [ADP1870-0.3-EVALZ](#) [ADP1871-0.6-EVALZ](#) [ADP1873-0.6-EVALZ](#) [ADP1874-0.3-EVALZ](#) [ADP1882-1.0-EVALZ](#) [ADP199CB-EVALZ](#) [ADP2102-1.25-EVALZ](#) [ADP2102-1.875EVALZ](#) [ADP2102-1.8-EVALZ](#) [ADP2102-2-EVALZ](#) [ADP2102-3-EVALZ](#) [ADP2102-4-EVALZ](#) [ADP2106-1.8-EVALZ](#) [ADP2147CB-110EVALZ](#) [AS3606-DB](#) [BQ24010EVM](#) [BQ24075TEVM](#) [BQ24155EVM](#) [BQ24157EVM-697](#) [BQ24160EVM-742](#) [BQ24296MEVM-655](#) [BQ25010EVM](#) [BQ3055EVM](#) [NCV891330PD50GEVB](#) [ISLUSBI2CKIT1Z](#) [LM2744EVAL](#) [LM2854EVAL](#) [LM3658SD-AEV/NOPB](#) [LM3658SDEV/NOPB](#) [LM3691TL-1.8EV/NOPB](#) [LM4510SDEV/NOPB](#) [LM5033SD-EVAL](#) [LP38512TS-1.8EV](#) [EVAL-ADM1186-1MBZ](#) [EVAL-ADM1186-2MBZ](#)