

DESCRIPTION

Demonstration circuit 994 features the LT3003 three channel LED ballaster with PWM in a 10-lead MSOP thermally enhanced MSE package. The demonstration circuit is designed to ballast three channels of LED current from 100mA to 350mA per channel. The PWM dimming function of the LT3003 eliminates the need for discrete MOSFETs. The LT3003 internally performs the level-shift required for non-ground referred PWM dimming in the buck mode and buck-boost mode topologies allowing PWM dimming input requirements to remain at logic-level. PWM dimming capabilities reach 3000:1 at 100Hz. Over temperature protection provides two open-collector pull-down outputs for direct interface with the compensation pin of most LT LED drivers and for use with a microcontroller. Additional thermal shutdown prevents the LT3003 from getting too hot.

The LT3003 can be configured in all LED driver topologies as long as there are three strings of LEDs

and the pin voltage requirements are met. The boost, buck mode, buck-boost mode, SEPIC, and buck LED driver topologies can all use the LT3003 three channel ballaster with PWM. The shutdown pin can be tied to the switcher shutdown pin or in buck-boost mode it must be tied to the PWM pin.

When a single LED channel is open and has no current, the other two channels cut back their current to zero or almost zero in order to protect themselves. The LED current per string rating is between 100mA and 350mA. The maximum voltage on VMAX pin is 48V and the maximum voltage on VIN pin is 40V.

For more details, please read the datasheet.

Design files for this circuit board are available. Call the LTC factory.

LT is a registered trademark of Linear Technology Corporation

QUICK START PROCEDURE

Follow the test procedure outlined below and see Figure1 to setup and test the LT3003 in the boost LED driver topology. The LT3003 needs to run with three strings of LEDs and an LED driver. The LEDs and LED driver do not come with DC994A, it is a standalone demonstration circuit that is meant to be used with different LED drivers in different topologies for evaluation.

1. Connect the three strings of LEDs from the LED+ terminal of the boost LED driver to the three LED terminals of the DC994A.
2. Connect the VEE terminal of the DC994A to the LED- (GND) terminal of the boost LED driver.
3. Connect the shutdown terminal of the DC994A to the shutdown terminal of the LED

driver or to the VIN terminal of the DC994A if the shutdown function is not being used.

4. Connect the VMAX terminal of the DC994A to the output voltage at the output capacitor of the boost LED driver. The DC841A shown in Figure 1 does not have a terminal for this node, so a wire has to be soldered to the output capacitor.
5. Connect a 3.3V or 5V bench supply with power OFF to the VIN and GND terminals of DC994A.
6. Connect a 3V to 10V bench supply with power OFF to the VIN and GND terminals of DC841A.
7. Turn on the input power supply for the DC994A.

QUICK START GUIDE FOR DEMONSTRATION CIRCUIT 994 THREE CHANNEL LED BALLASTER WITH PWM

8. Turn on the input power supply for the boost LED driver and set the voltage.
9. Observe the LEDs working properly at 100mA to 350mA per string without looking straight at the LEDs. The extreme brightness may be harmful to the eye.
10. For PWM dimming, tie the PWM terminal of the DC994A to the PWM dimming input of the boost LED driver if the driver has a PWM dim input. Attach a logic-level PWM dimming pulse waveform to the PWM terminal of the DC994A at 100Hz with as high as 3000:1 PWM dimming ratio determined by the boost LED driver. Observe the PWM dimming brightness of the LEDs without looking straight at them.

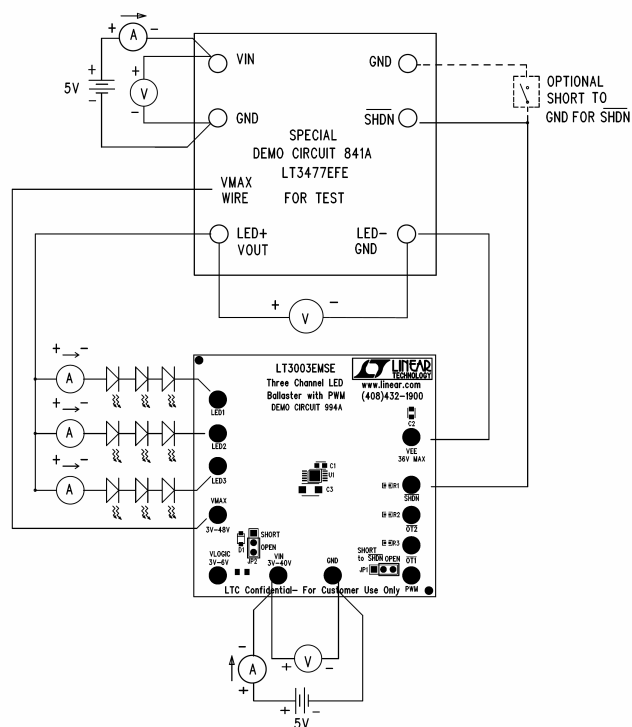

Figure 1 Proper Measurement Equipment Setup with DC841A in Boost Mode JP1=JP2=open

DC994A OPTIONS

VIN PIN VOLTAGE RANGE

The operating pin voltage range for VIN pin on the LT3003 is 3V to 40V. In most cases, it is not desirable to tie VIN to the highest rail available due to both excessive IC power consumption and to LED string current matching accuracy. It is most optimal to tie the VIN pin to a voltage that is between 3V and 7V higher than the VEE pin voltage. In the cases of boost LED driver and buck LED driver (LT3474 / LT3475), when the VEE pin is tied to ground, a 3.3V or 5V supply on the VIN pin of the LT3003 is optimal for best LED string current matching. In buck-boost mode and buck mode LED topologies, the VIN pin of the LT3003 should be tied to the VMAX pin rail (Vout and Vin of the LED driver respectively) through a zener diode that has a breakdown voltage of $V_f = V_{fLED} - 5V$ approximately. This makes the VIN pin voltage about 4V above the VEE pin voltage that is not ground-referred.

PWM DIMMING

DC994A is designed to provide LED PWM dimming in every LED driver topology with a logic-level PWM dimming input directly tied into the PWM pin of the LT3003. The necessary level-shifting of the PWM dimming signal is designed into the IC, eliminating extra level-shifting discrete components from the circuit in certain topologies and replacing the PWM dimming MOSFET in all topologies.

Some LED drivers have a PWM pin that can be tied to the PWM pin of the LT3003 and to the same PWM signal as shown in Figures 2, 3, and 4. The LT3003 PWM function also works with LED drivers that do not have a PWM pin. Please refer to the datasheet for details.

When not in use, the PWM pin of the LT3003 can be left floating. There is an internal pull-up on the PWM dimming pin that eliminates the need to tie this pin high. In

QUICK START GUIDE FOR DEMONSTRATION CIRCUIT 994

THREE CHANNEL LED BALLASTER WITH PWM

buck-boost mode, the LT3003 PWM pin is shown to be tied to the shutdown pin of the LT3003. This is needed when PWM dimming is being used so that the VIN pin current does not drain the output capacitor during PWM off time by putting the IC in shutdown. If this is not an issue, the shutdown pin can be released from the PWM pin and should be tied high or to the system shutdown signal instead. When the two pins PWM and /SHDN are not tied together and PWM dimming is being used, the maximum PWM dimming ratio is reduced when compared with the case where the two pins are tied together.

BOOST, BUCK, BUCK MODE, AND BUCK-BOOST MODE TOPOLOGIES

The LT3003 can be configured to work with any LED driver topology. The different topologies such as boost, buck, buck mode, and buck-boost mode are shown in the LT3003 datasheet and below. The different topologies accommodate the different relationships between the input voltage range and the LED string voltage range. The LT3003 datasheet covers the different topologies as shown in the figure below. Although these topology schematics are shown in the LT3003 datasheet, the VIN pin should not generally be tied directly to VIN or VOUT of the LED driver circuit. A zener diode or other supply should be used with the VIN pin to keep the VIN – VEE pin voltage between 3V and 7V for minimal IC heating and for optimal LED string current matching.

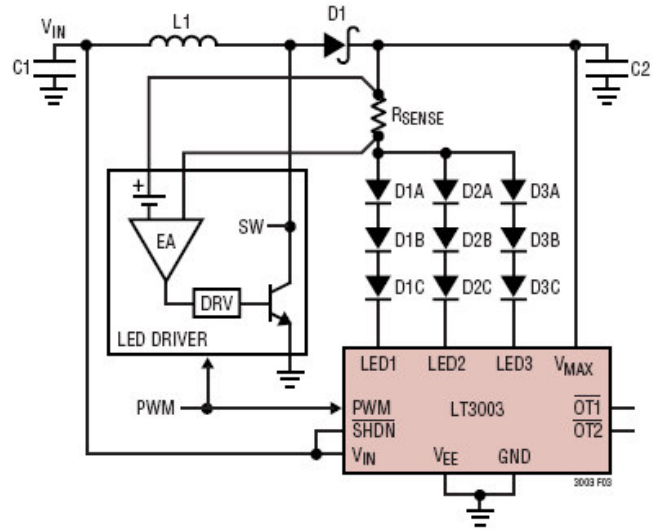

Figure 2 Boost LED driver topology

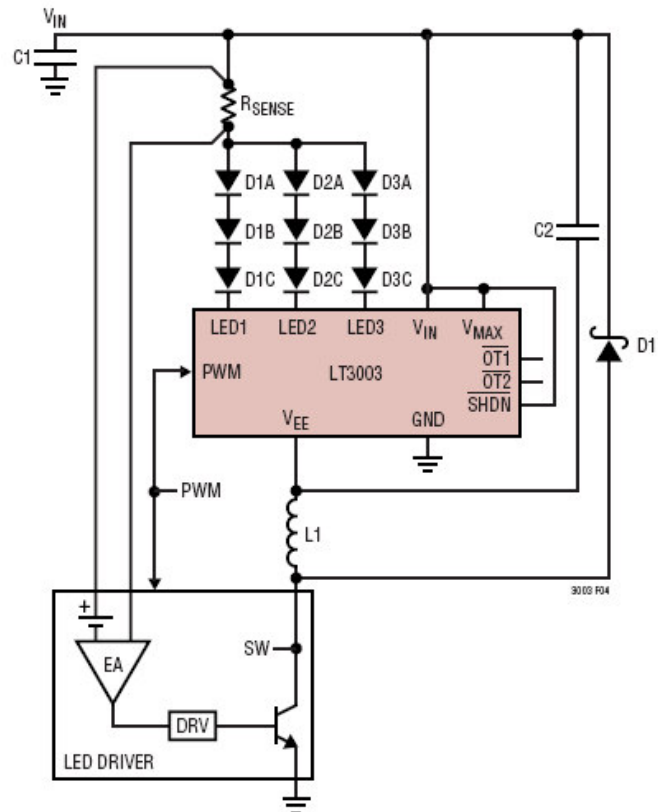

Figure 3 Buck mode LED driver topology

QUICK START GUIDE FOR DEMONSTRATION CIRCUIT 994

THREE CHANNEL LED BALLASTER WITH PWM

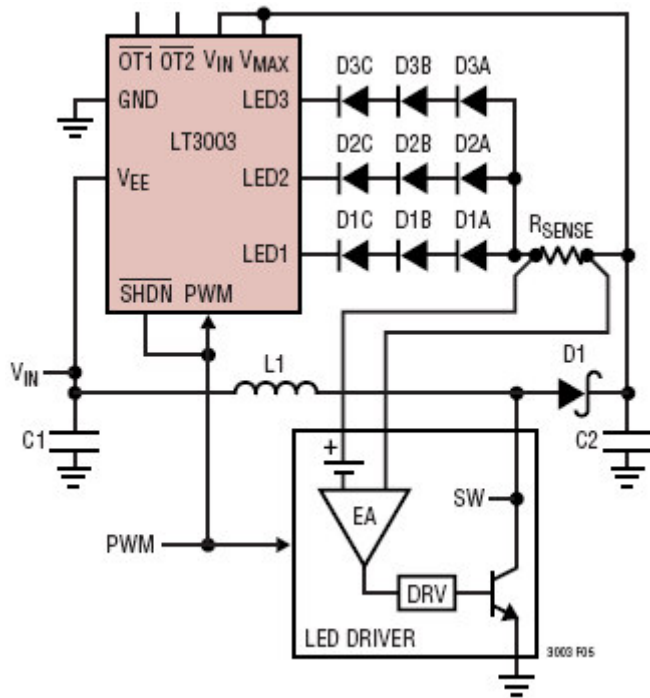

Figure 4 Buck-boost mode LED driver topology

QUICK START GUIDE FOR DEMONSTRATION CIRCUIT 994

THREE CHANNEL LED BALLASTER WITH PWM

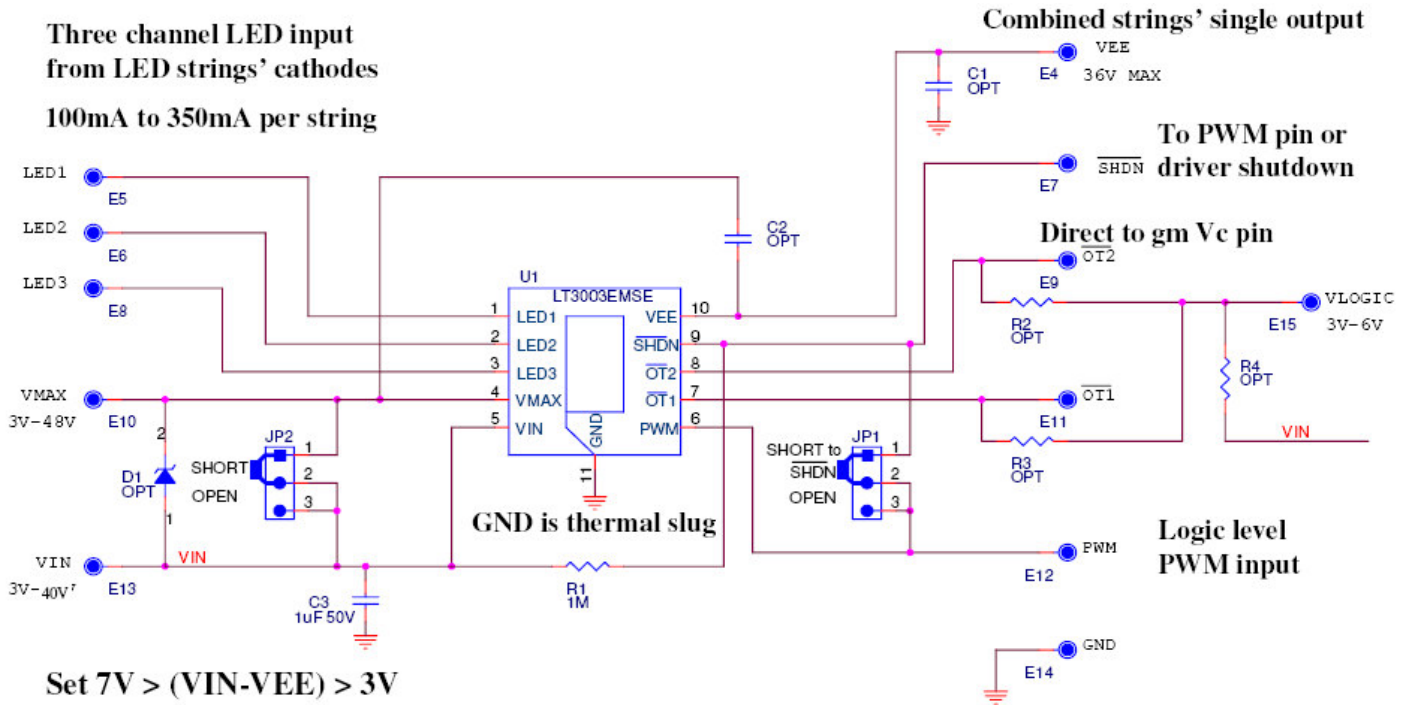

Figure 5 DC994A schematic with features

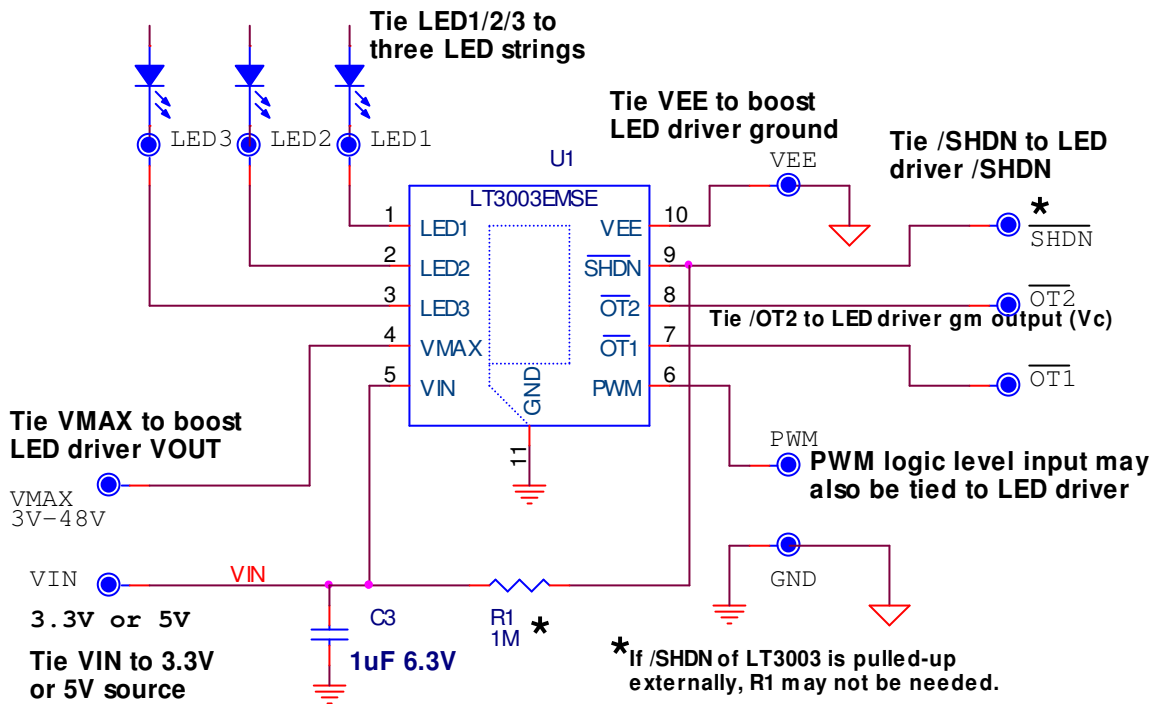

Figure 6 DC994A **boost** LED driver setup - /OT1 & /OT2 terminals, /SHDN terminal*, PWM terminal float is okay (JP1, JP2 = OPEN)

QUICK START GUIDE FOR DEMONSTRATION CIRCUIT 994

THREE CHANNEL LED BALLASTER WITH PWM

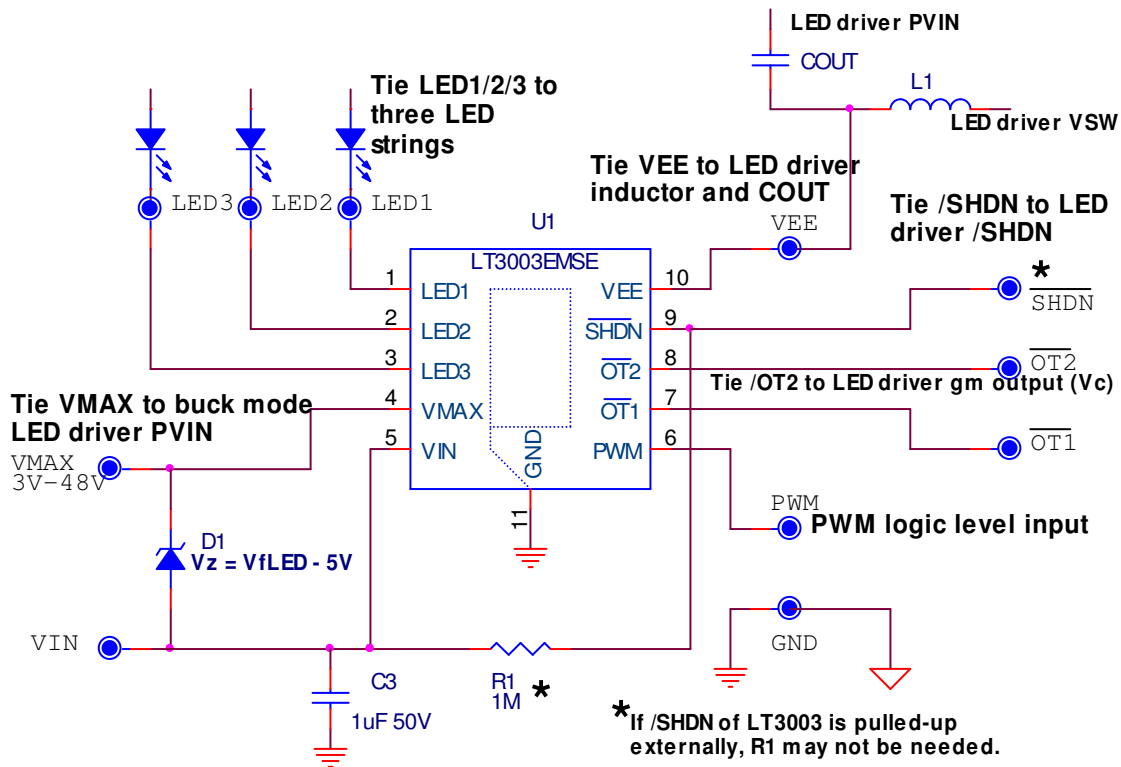

Figure 7 DC994A **buck mode** LED driver setup – VIN terminal, /OT1 & /OT2 terminals, PWM terminal, /SHDN terminal* float is okay (JP1, JP2 = OPEN)

QUICK START GUIDE FOR DEMONSTRATION CIRCUIT 994

THREE CHANNEL LED BALLASTER WITH PWM

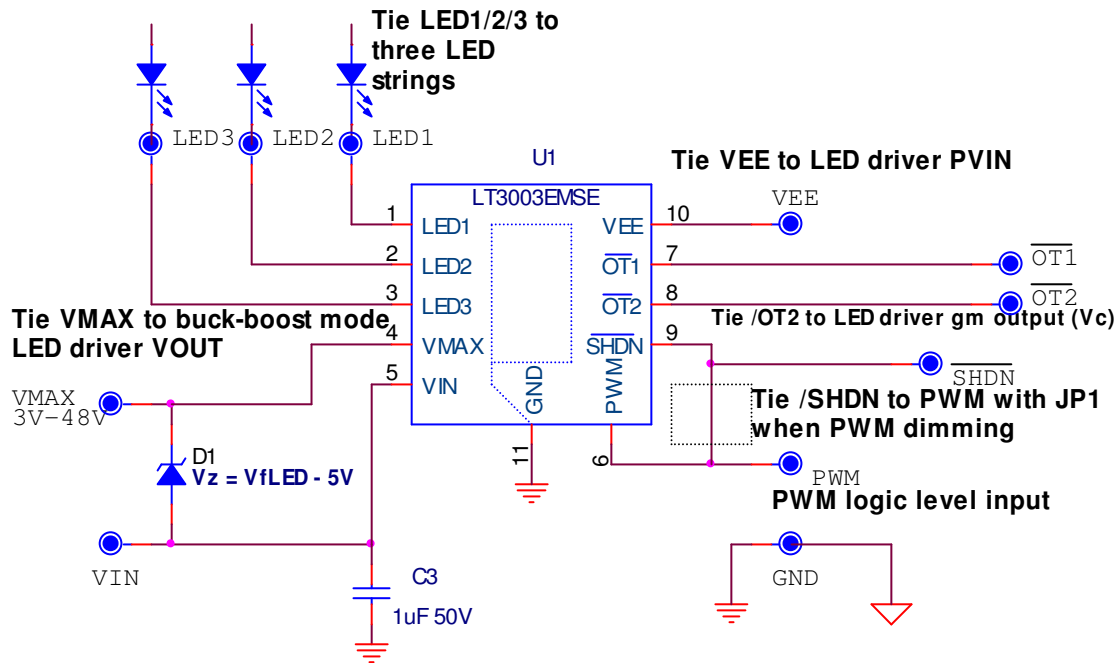

Figure 8 DC994A LT3003 **buck-boost mode** LED driver setup – VIN terminal, /OT1 & /OT2 terminals float is okay – PWM pin float is okay, but when not PWM dimming /SHDN must be connected to system shutdown signal or VIN (JP2 = OPEN, JP1 = OPEN when not PWM dimming)

QUICK START GUIDE FOR DEMONSTRATION CIRCUIT 994

THREE CHANNEL LED BALLASTER WITH PWM

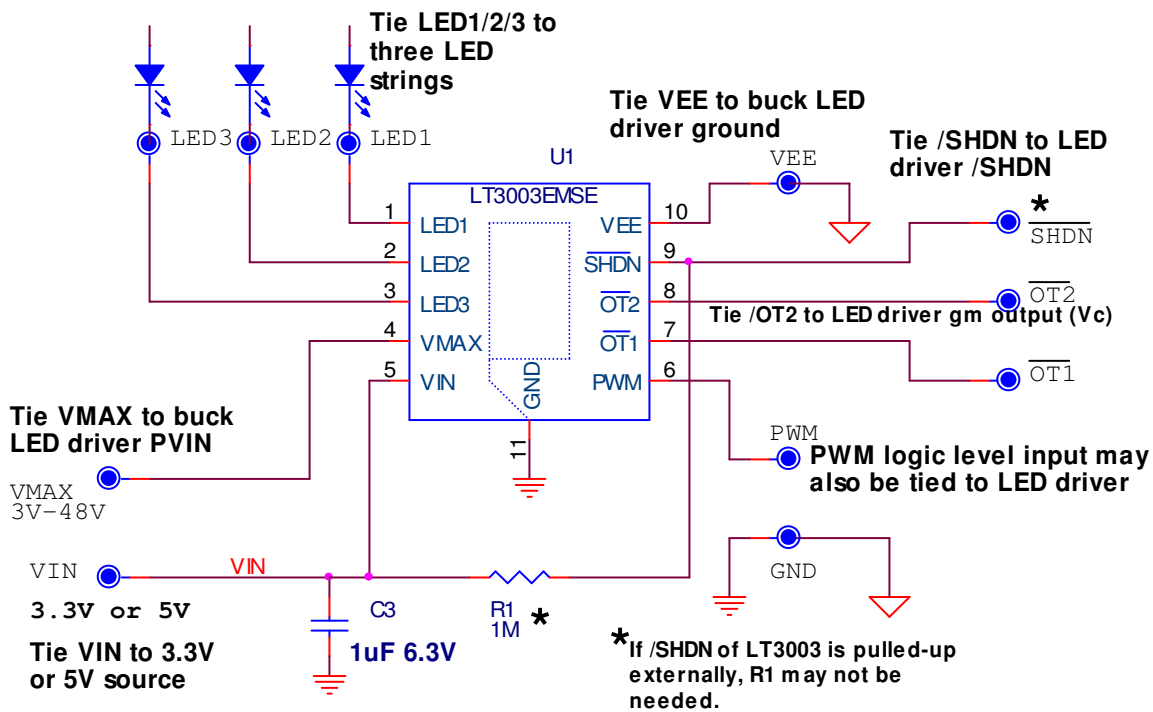
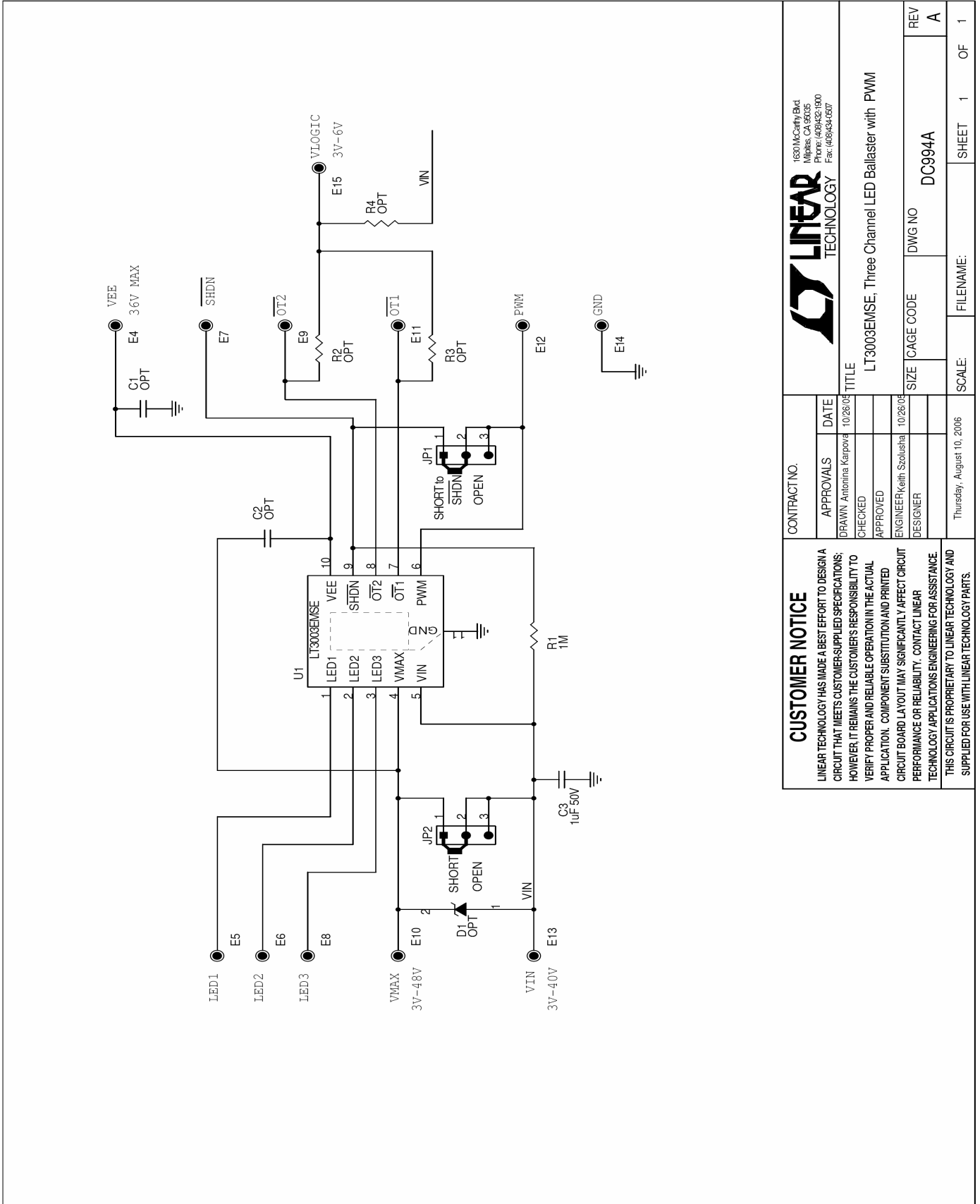

Figure 9 DC994A LT3003 **buck** LED driver setup with ICs such as the LT3474/LT3475 – PWM terminal, /SHDN terminal*, /OT2 & /OT1 terminals float is okay (JP1, JP2 = OPEN)

QUICK START GUIDE FOR DEMONSTRATION CIRCUIT 994

THREE CHANNEL LED BALLASTER WITH PWM



CUSTOMER NOTICE		CONTRACT NO.	
LINEAR TECHNOLOGY HAS MADE A BEST EFFORT TO DESIGN A CIRCUIT THAT MEETS CUSTOMER-SUPPLIED SPECIFICATIONS; HOWEVER, IT REMAINS THE CUSTOMER'S RESPONSIBILITY TO VERIFY PROPER AND RELIABLE OPERATION IN THE ACTUAL APPLICATION. COMPONENT SUBSTITUTION AND PRINTED CIRCUIT BOARD LAYOUT MAY SIGNIFICANTLY AFFECT CIRCUIT PERFORMANCE OR RELIABILITY. CONTACT LINEAR TECHNOLOGY APPLICATIONS ENGINEERING FOR ASSISTANCE. THIS CIRCUIT IS PROPRIETARY TO LINEAR TECHNOLOGY AND SUPPLIED FOR USE WITH LINEAR TECHNOLOGY PARTS.		DRAWN: Antonina Karпова	
		DATE: 10/26/04	
		CHECKED: APPROVED	
		ENGINEER: Keith Szolusha	
		DESIGNER:	
		Thursday, August 10, 2006	
		SCALE:	
		FILENAME:	
		DWG NO: DC994A	
		REV: A	
		SHEET: 1 OF 1	

LINEAR TECHNOLOGY

1680 McCarthy Blvd
Milpitas, CA 95035
Phone: (415) 961-8000
Fax: (415) 964-6507

LINEAR TECHNOLOGY

TITLE: LT3003EMSE, Three Channel LED Ballaster with PWM

X-ON Electronics

Largest Supplier of Electrical and Electronic Components

Click to view similar products for [LED Lighting Development Tools](#) category:

Click to view products by [Analog Devices](#) manufacturer:

Other Similar products are found below :

[MIC2870YFT EV](#) [ADP8860DBCP-EVALZ](#) [LM3404MREVAL](#) [ADM8843EB-EVALZ](#) [TDGL014](#) [ISL97682IRTZEVALZ](#) [LM3508TLEV](#)
[EA6358NH](#) [MAX16826EVKIT](#) [MAX16839EVKIT+](#) [TPS92315EVM-516](#) [MAX1698EVKIT](#) [MAX6956EVKIT+](#) [OM13321,598](#) [DC986A](#)
[DC909A](#) [DC824A](#) [STEVAL-LLL006V1](#) [IS31LT3948-GRLS4-EB](#) [104PW03F](#) [PIM526](#) [PIM527](#) [MAX6946EVKIT+](#) [MAX20070EVKIT#](#)
[MAX21610EVKIT#](#) [MAX20090BEVKIT#](#) [MAX20092EVSYS#](#) [PIM498](#) [AP8800EV1](#) [ZXLD1370/1EV4](#) [MAX6964EVKIT](#)
[MAX25240EVKIT#](#) [MAX25500TEVKITC#](#) [MAX77961BEVKIT06#](#) [1216.1013](#) [TPS61176EVM-566](#) [TPS61197EVM](#) [TPS92001EVM-628](#)
[1270](#) [1271.2004](#) [1272.1030](#) [1273.1010](#) [1278.1010](#) [1279.1002](#) [1279.1001](#) [1282.1000](#) [1293.1900](#) [1293.1800](#) [1293.1700](#) [1293.1500](#)