

3.3V, 1.5A Synchronous Buck-Boost Converter

DESCRIPTION

Demonstration circuit 999A is a wide input range, 3.3V, 1.5A Synchronous Buck-Boost Converter featuring the LTC3533.

This circuit was designed to demonstrate the high levels of performance, efficiency, and small solution size attainable using this part in a buck-boost power supply. It operates at 1.0MHz and produces a regulated 3.3V, 1.5A output from an input voltage range of 2.4 to 5.5V, and operates down to 1.8V with de-rated output current. It is suitable for portable applications, and has a footprint area that is 0.25 square inches.

Synchronous rectification helps to attain efficiency up to 94%, depending on line and load. The LTC3533 provides current limit and shutdown disconnect. It offers Burst Mode operation for high efficiency at light loads.

Design files for this circuit board are available. Call the LTC factory.

LT, LTC, LTM, LT, Burst Mode, OPTI-LOOP, Over-The-Top and PolyPhase are registered trademarks of Linear Technology Corporation. Adaptive Power, C-Load, DirectSense, Easy Drive, FilterCAD, Hot Swap, LinearView, μ Module, Micropower SwitcherCAD, Multimode Dimming, No Latency $\Delta\Sigma$, No Latency Delta-Sigma, No R_{SENSE} , Operational Filter, PanelProtect, PowerPath, PowerSOT, SmartStart, SoftSpan, Stage Shedding, SwitcherCAD, ThinSOT, UltraFast and VLDO are trademarks of Linear Technology Corporation. Other product names may be trademarks of the companies that manufacture the products.

PERFORMANCE SUMMARY Specifications are at TA = 25°C

SYMBOL	PARAMETER	CONDITIONS	MIN	TYP	MAX	UNITS
V_{IN}	Input Supply Range		1.8		5.5	V
V_{OUT}	Output Voltage			3.3		V
I_{OUT}	Output Current Range	$V_{IN} = 2.4 - 5.5V$	0		1.5	A
I_{OUT}	Maximum Output Current	$V_{IN} = 0.8V$ (linear interpolation from 0.8 – 2.4V)			0.8	A
F_{SW}	Switching (Clock) Frequency			1.0		MHz
$V_{OUT\ P-P}$	Output Ripple	$V_{IN} = 4.2V, I_{OUT} = 1.5A$ (20MHz BW)		20		mV _{P-P}
I_{REG}	Output Regulation	Line and Load (1.8-5.5V, 0-1.5A)		± 0.4		%
P_{OUT}/P_{IN}	Efficiency (see Figure 2)	$V_{IN} = 4.2V, I_{OUT} = 1.5A$		89		%

OPERATING PRINCIPLES

The LTC3533 Synchronous Buck-Boost Converter is employed to produce a 3.3V output from an input ranging from 1.8V to 5.5V.

The converter utilizes a proprietary 4-switch topology to provide an output that is within the input voltage

range. It seamlessly transitions from buck, to buck-boost, to boost modes of operation to maintain the output as the input voltage goes from maximum to minimum values.

QUICK START PROCEDURE

Demonstration circuit 999 is easy to set up to evaluate the performance of the LTC3533. Refer to Figure 1 for proper measurement equipment setup and follow the procedure below:

NOTE. When measuring the output voltage ripple, care must be taken to avoid a long ground lead on the oscilloscope probe. Measure the output voltage ripple by touching the probe tip and ground ring directly across the last output capacitor (COUT) as shown in Figure 1.

1. Set an input power supply that is capable of 1.8V to 5.5V to 4.2V. Turn off the supply.
2. With power off, connect the supply to the input terminals +Vin and –Vin.
 - a. Input voltages lower than 1.8V can keep the converter from turning on due to the undervoltage lockout feature of the LTC3533.
 - b. If efficiency measurements are desired, an ammeter capable of measuring 3Adc or a resistor shunt can be put in series with the input supply in order to measure the DC999A's input current.
 - c. A voltmeter with a capability of measuring at least 5.5V can be placed across the input terminals in order to get an accurate input voltage measurement.
3. Turn on the power at the input.

NOTE. Make sure that the input voltage never exceeds 5.5V.

4. Check for the proper output voltage of 3.3V. Turn off the power at the input.
5. Once the proper output voltages are established, connect a variable load capable of sinking 1.5A at 3.3V to the output terminals +Vout and –Vout. Set the current for 0A.
 - a. If efficiency measurements are desired, an ammeter or a resistor shunt that is capable of handling 1.5Adc can be put in series with the output load in order to measure the DC999A's output current.
 - b. A voltmeter with a capability of measuring at least 3.3V can be placed across the output terminals in order to get an accurate output voltage measurement.
6. Turn on the power at the input.

NOTE. If there is no output, temporarily disconnect the load to make sure that the load is not set too high.
7. Once the proper output voltage is again established, adjust the load within the operating range and observe the output voltage regulation, ripple voltage, efficiency and other desired parameters.

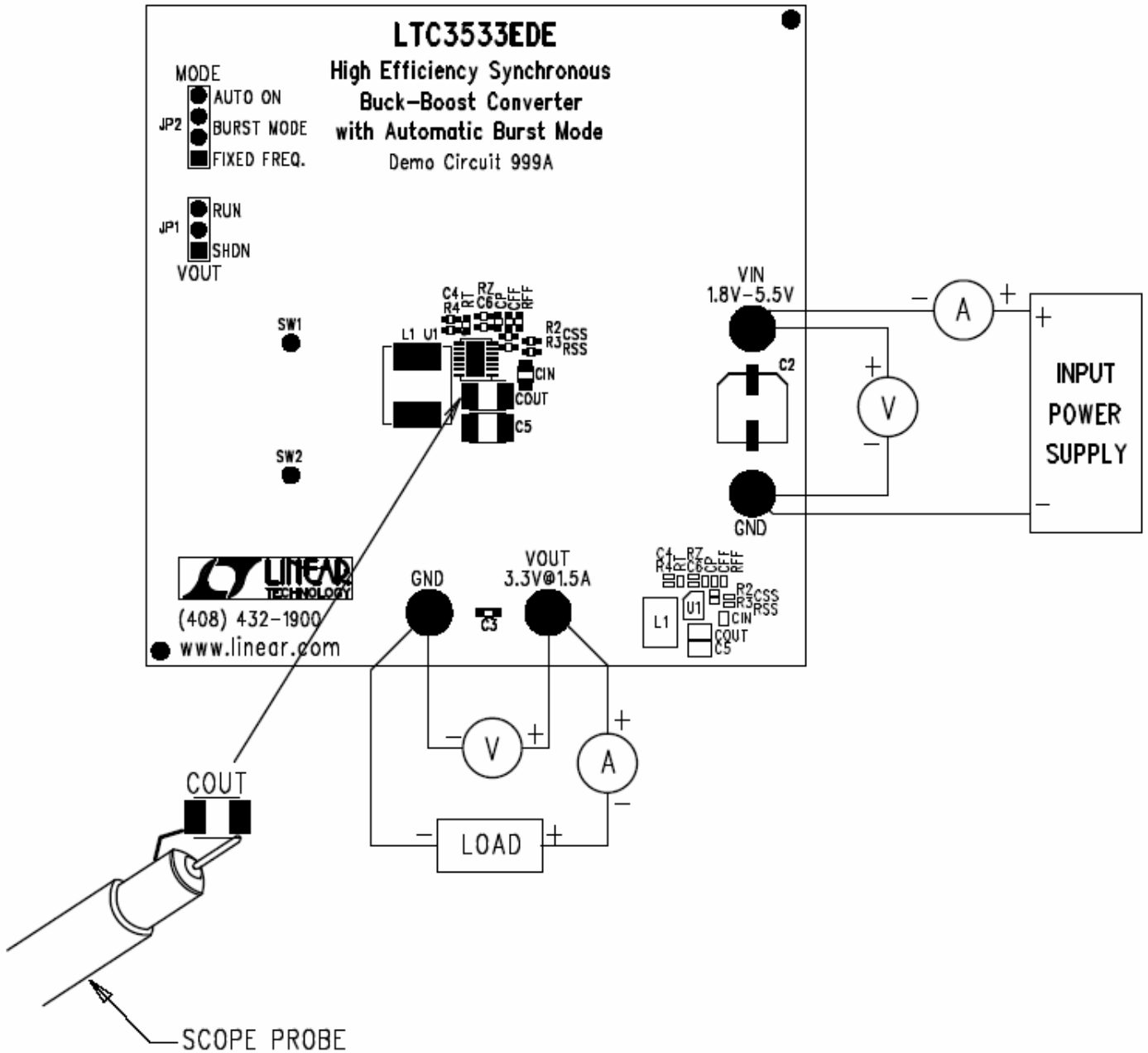

Figure 1. Proper Measurement Equipment Setup

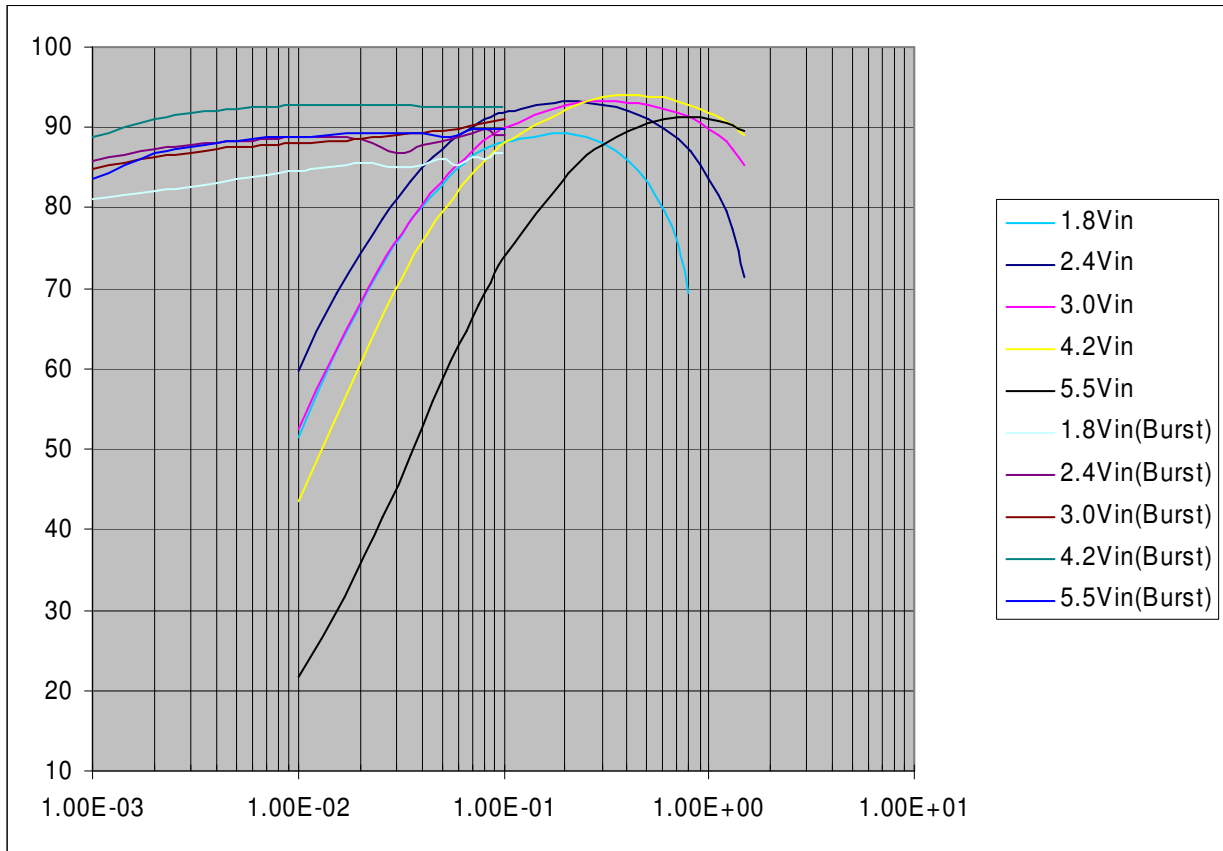

Figure 2. Efficiency – Note 90%+ efficiency over a wide current range.

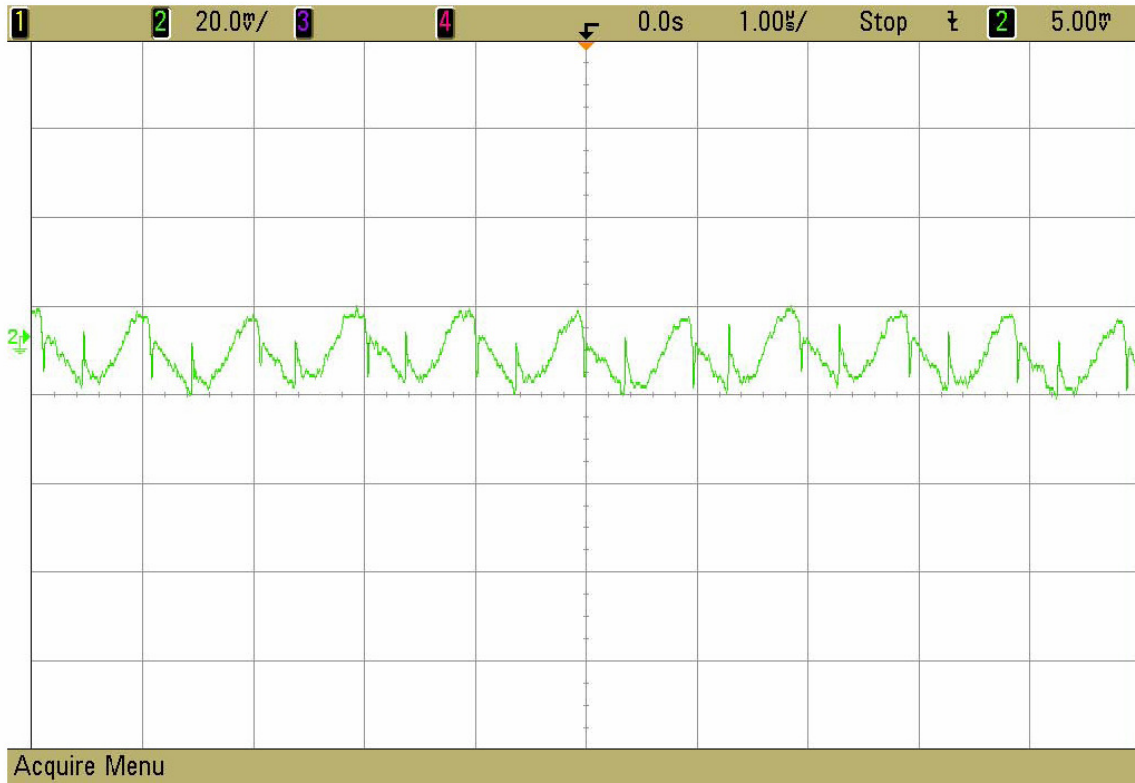

Figure 3. Output Ripple at 2.6V_{in} and 1.5A_{out} (20MHz) - 1µs and 20mV / div

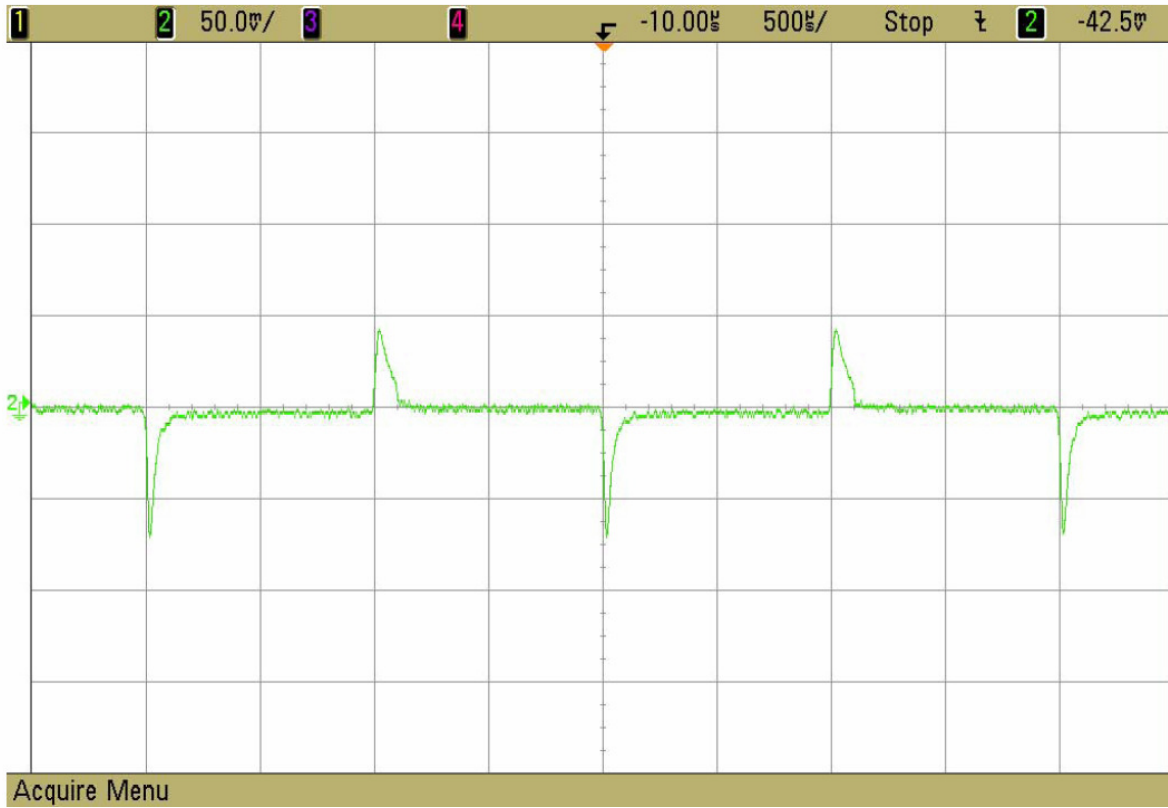
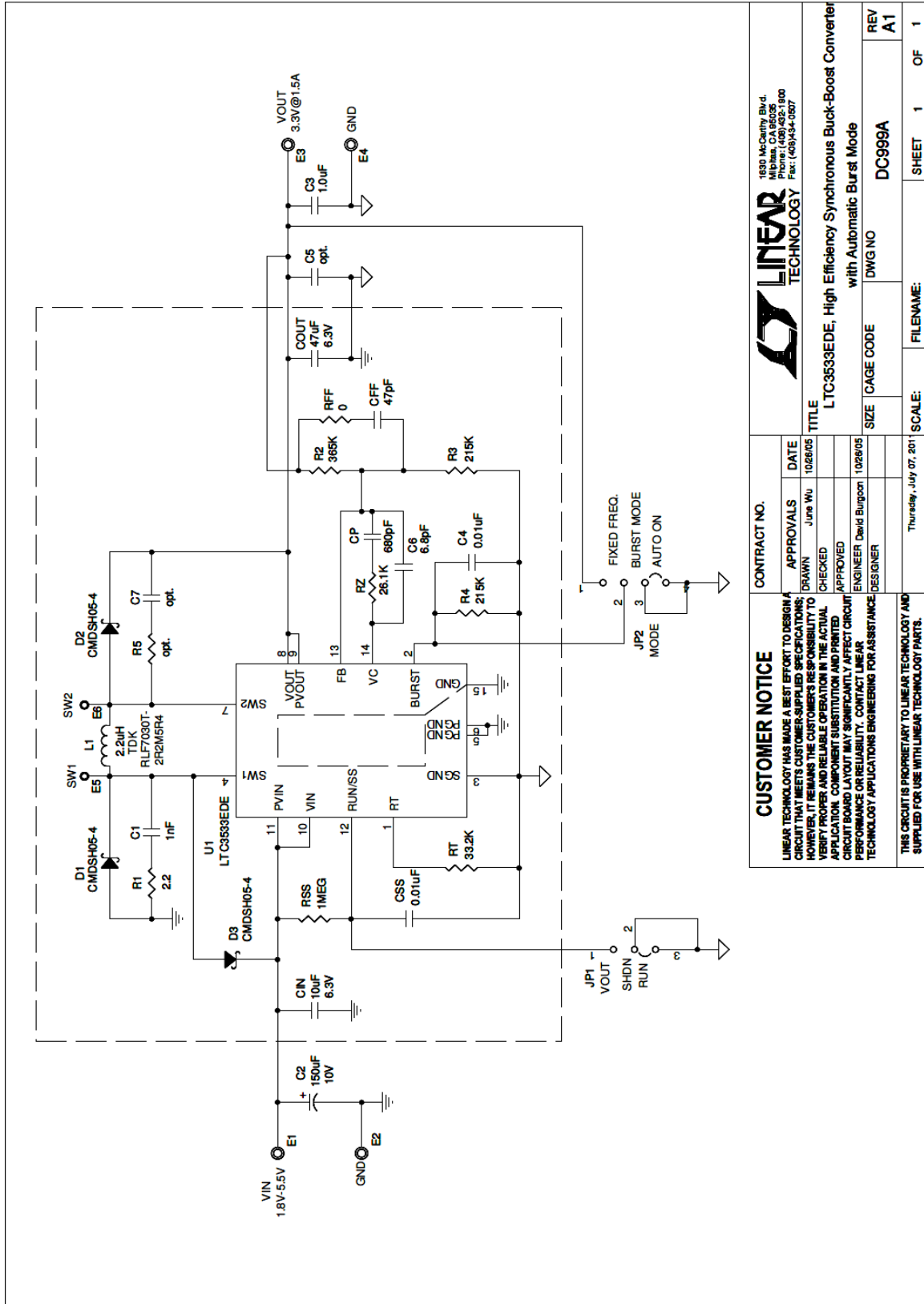

Figure 4. Transient Response Waveform at 4.2Vin and 0.75 - 1.5Aout – 500uS and 50mV / div



CUSTOMER NOTICE		CONTRACT NO.	
LINEAR TECHNOLOGY HAS MADE A BEST EFFORT TO DESIGN A CIRCUIT THAT MEETS CUSTOMER-SUPPLIED SPECIFICATIONS; HOWEVER, IT REMAINS THE CUSTOMER'S RESPONSIBILITY TO VERIFY PROPER AND RELIABLE OPERATION IN THE ACTUAL APPLICATION. COMPONENT SUBSTITUTION AND PRINTED CIRCUIT BOARD LAYOUT MAY SIGNIFICANTLY AFFECT CIRCUIT PERFORMANCE OR RELIABILITY. CONTACT LINEAR TECHNOLOGY APPLICATIONS ENGINEERING FOR ASSISTANCE.		APPROVALS	DATE
THIS CIRCUIT IS PROPRIETARY TO LINEAR TECHNOLOGY AND SUPPLIED FOR USE WITH LINEAR TECHNOLOGY PARTS.		DRAWN	JUNE WU
		CHECKED	10/26/05
		APPROVED	
		ENGINEER	DAVID BURGMAN
		DESIGNER	10/26/05
		SIZE	CAGE CODE
		DWG NO	DC9999A
		SCALE:	FILENAME:
		Thursday, July 07, 2011	
REV	A1	SHEET	1 OF 1

1630 McCarthy Blvd.
 Milpitas, CA 95035
 Phone: (408) 432-1900
 Fax: (408) 432-0307

LINEAR TECHNOLOGY

TITLE
 LTC3533EDE, High Efficiency Synchronous Buck-Boost Converter with Automatic Burst Mode

APPROVALS

DRAWN: JUNE WU

CHECKED: 10/26/05

APPROVED:

ENGINEER: DAVID BURGMAN

DESIGNER: 10/26/05

CONTRACT NO.

DATE

SIZE

CAGE CODE

DWG NO

DC9999A

SCALE:

FILENAME:

Thursday, July 07, 2011

REV

A1

SHEET

1 OF 1

X-ON Electronics

Largest Supplier of Electrical and Electronic Components

Click to view similar products for [Power Management IC Development Tools](#) *category:*

Click to view products by [Analog Devices](#) *manufacturer:*

Other Similar products are found below :

[EVAL-ADM1168LQEBZ](#) [EVB-EP5348UI](#) [MIC23451-AAAYFL EV](#) [MIC5281YMME EV](#) [DA9063-EVAL](#) [ADP122-3.3-EVALZ](#) [ADP130-0.8-EVALZ](#) [ADP130-1.2-EVALZ](#) [ADP130-1.5-EVALZ](#) [ADP130-1.8-EVALZ](#) [ADP1714-3.3-EVALZ](#) [ADP1716-2.5-EVALZ](#) [ADP1740-1.5-EVALZ](#) [ADP1752-1.5-EVALZ](#) [ADP1828LC-EVALZ](#) [ADP1870-0.3-EVALZ](#) [ADP1871-0.6-EVALZ](#) [ADP1873-0.6-EVALZ](#) [ADP1874-0.3-EVALZ](#) [ADP1882-1.0-EVALZ](#) [ADP199CB-EVALZ](#) [ADP2102-1.25-EVALZ](#) [ADP2102-1.875EVALZ](#) [ADP2102-1.8-EVALZ](#) [ADP2102-2-EVALZ](#) [ADP2102-3-EVALZ](#) [ADP2102-4-EVALZ](#) [ADP2106-1.8-EVALZ](#) [ADP2147CB-110EVALZ](#) [AS3606-DB](#) [BQ24010EVM](#) [BQ24075TEVM](#) [BQ24155EVM](#) [BQ24157EVM-697](#) [BQ24160EVM-742](#) [BQ24296MEVM-655](#) [BQ25010EVM](#) [BQ3055EVM](#) [NCV891330PD50GEVB](#) [ISLUSBI2CKIT1Z](#) [LM2744EVAL](#) [LM2854EVAL](#) [LM3658SD-AEV/NOPB](#) [LM3658SDEV/NOPB](#) [LM3691TL-1.8EV/NOPB](#) [LM4510SDEV/NOPB](#) [LM5033SD-EVAL](#) [LP38512TS-1.8EV](#) [EVAL-ADM1186-1MBZ](#) [EVAL-ADM1186-2MBZ](#)