



Typical Applications

The HMC988LP3E is ideal for:

- Basestation Digital Pre-Distortion Paths(DPD)
- High Performance Automated Test Equipment(ATE)
- Backplane clock skew management
- Phase Coherence of multiple clock paths
- Clock Delay management to improve setup & hold time margins
- PCB signal flight time offset circuits
- Track and hold circuits for ADC/DACs

Functional Diagram

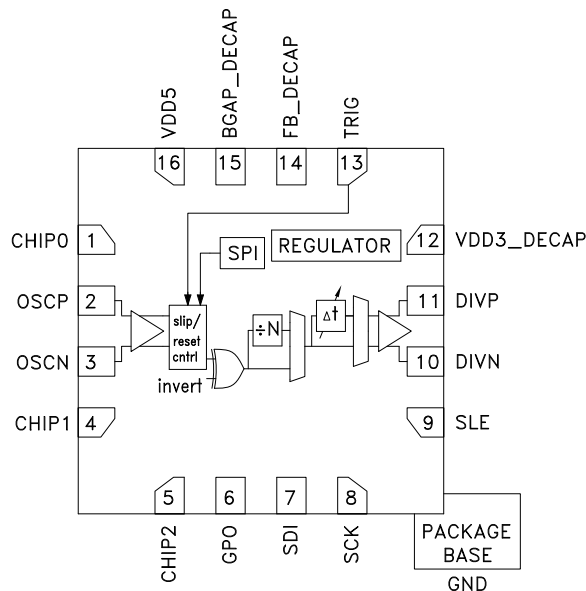

Features

- DC - 4 GHz
- 170 dBc/Hz floor @ 100 MHz output
- 164 dBc/Hz floor @ 2 GHz output
- Integrated Jitter 35 fs_{RMS} @ 100 MHz output
- 13 fs_{RMS} (calculated) @ 2 GHz output
- Adjustable output phase with soft/hard reset sync
- Adjustable output delay in 60 steps of 20 ps
- Flexible Input Interface:
 - LVPECL, LVDS, CML, CMOS Compatible
 - AC or DC Coupling
 - On - Chip Termination 50 Ω (100 Ω Differential)
- Output Driver (LVPECL):
 - 800 mVpp LVPECL into 50 Ω Single-Ended (+3 dBm Fo)
- Up to 8 addressable dividers per SPI bus
- 3.3 V operation or 5 V operation with Optional on-chip regulator for best performance
- 3 x 3 QFN Leadless SMT Package

General Description

The HMC988LP3E is an ultra low noise clock divider capable of dividing by 1/2/4/8/16/32. It is a versatile device with additional functionality including adjustable output phase, adjustable delay in 60 steps of ~ 20 ps, a clock synchronization function, and a clock invert option.

Housed in a compact 3x3 mm SMT QFN package, the clock divider offers a high level of functionality. The device works with 3.3 V supply or may be connected to 5 V supply and utilize the optional on-chip regulator. This on-chip regulator may be bypassed.

Up to 8 addressable HMC988LP3E devices can be used together on the SPI bus.

The HMC988LP3E is ideally suited for data converter applications with extremely low phase noise requirements.

PROGRAMMABLE CLOCK DIVIDER AND DELAY DC - 4 GHz

Table 1. Electrical Specifications

Unless otherwise specified: T = +25 °C. Current consumptions assumes fine adjustable delay is disabled. Phase noise degrades approximately 15 dB if using fine delay adjustment.

Parameter	Conditions	Min	Typ.	Max	Units
OSCP/N Input Frequency Range		DC		4	GHz
DIVP/N Output Frequency Range		DC		4	GHz
Divide Ratios			1/2/4/8/16/32		
Maximum Fine Delay Adjust Frequency		DC		1	GHz
VDD	with on-chip regulator	+3.7	+4.5	+5.5	V
VDD	bypass on-chip regulator	+3.1	+3.3	+3.5	V
Input Swing (LVPECL or AC)			0.800 See Figure 9		V _{pp}
Output Swing (LVPECL) [1]	Measured into a 50ohm Load		0.8 (single ended)		V _{pp}
	Measured into a 50ohm Load		1.6 (differential)		V _{ppd}
Rise/Fall Time (LVPECL OUT)	20%/80%		90		ps
OSCP/N Input Common Mode DC Bias [2]		+1.6	+2	+2.5	V
DIVP/N Output Common Mode Voltage [1]			+2		V
Phase Noise (@100 MHz offset) [3]	@ 100 MHz output		-170		dBc/Hz
	@ 500 MHz output		-168		
	@ 1 GHz output		-166		
	@ 2 GHz output		-164		
Jitter Density [4]	@ 100 MHz output		7.1		asec/√Hz
	@ 500 MHz output		1.8		
	@ 1 GHz output		1.1		
	@ 2 GHz output		0.7		
Integrated Jitter (12k - 20MHz) [5]	@ 100 MHz output		32		fsec
	@ 500 MHz output [6]		8		
	@ 1 GHz output [6]		5		
	@ 2 GHz output [6]		3.2		
FOM (Figure of Merit) Noise Floor	Noise Floor = FOM+10Log(Fout)		-254		dBc/Hz
Coarse Delay Adjustment Range			1/2 to ∞ *T _{INPUT}		Input Cycles
Fine Delay Adjustment Range [7]	60 steps of ~ 20 ps; Delay compresses with increasing frequency. See Figure 6. With divider bypassed maximum frequency limited to 650MHz	300		1500	ps
Fine Delay Adjustment Resolution			20		ps
Fine Delay Adjustment Step Count			60		
PSRR [8]					
	With Regulator	AM	-70	-80	dBc
		PM	-80	-92	dBc



Table 1. Electrical Specifications					
Unless otherwise specified: T = +25 °C. Current consumptions assumes fine adjustable delay is disabled. Phase noise degrades approximately 15 dB if using fine delay adjustment.					
Parameter	Conditions	Min	Typ.	Max	Units
Bypass Regulator	AM	-40		-50	dBc
	PM	-50		-70	dBc
Current Consumption					
Stand-by Current - Chip Disabled	using Regulator case		0.7		mA
	bypass Regulator case		0.01		mA
Minimum Current [9]			68		mA
Additive Divider			16	21	mA
Delay Line Current			12	44	mA
LVPECL Termination Load Current			26	40	mA
Propagation Delay	Delay Line Disabled		210		ps
Delay vs Temp	250 MHz (Setpoint 15)			350	fs/ °C
	1 GHz (Setpoint 15)			150	fs/ °C
Logic Inputs: CHIP0, CHIP1, CHIP 2, SLE,SDI, SCK, TRIG					
Input Logic Low, Vil				0.9	V
Input Logic High, Vih		2.1			V

[1] Using standard LVPECL termination as shown in Figure 9

[2] When Reg04[03]=1, Default Setting=0

[3] Phase noise performance is characterized using the HMC1034 as a source at ~2 GHz, 9 dBm differential. For sinusoidal low-frequency inputs, the phase noise may degrade. For example, a single-ended 100 MHz 9 dBm sin-wave in bypass mode produces a phase noise floor of -164 dBc/Hz as opposed to -170 dBc/Hz.

[4] To calculate Jitter Density, $(\sqrt{2} \cdot 10^{-(\text{Floor phase noise}/20)/2\pi}) \cdot (1/\text{frequency})$ i.e jitter density @ 500 MHz = $(\sqrt{2} \cdot 10^{-(168/20)/2\pi}) \cdot (1/500000000)$

[5] Integrated Bandwidth start from 12 KHz to 20 MHz, Jitter Density x $\sqrt{\text{Desired customized BW}}$ i.e integrated jitter @ 2 GHz over a 6 GHz BW = $0.7 \text{ asec}/\sqrt{\text{Hz}} \times \sqrt{6 \text{ GHz}}$ 1asec = 1/1000 of a femtosecond. Only 100 MHz number is measured with 100 MHz Wenzel and HMC988 in bypass mode

[6] These integrated jitter number are based on calculation.

[7] The fine delay adjustment is valid up to a 1 GHz output frequency. Maximum frequency is 650MHz with divider bypassed (divide-by-1).

[8] Spur caused by 100 mVpp Aggressor tone on input supply. This specification is the level of the SSB spur which appears symmetrically around the output frequency when the input supply stimulated by a 100 mVpp aggressive tone @ 30 kHz. The spur level is linearly proportional to the aggressor tone amplitude. It is relatively independent of input and output frequencies, and input power level. When regulated, at least 3.7 V must be applied to the input power supply to provide sufficient PSRR. The spur level is not appreciably different for single ended or differential operation. The frequency response to the aggressive tone is flat from 1 kHz to 50 kHz offset. Above 50 kHz the solution PSRR improves strongly, but is largely dependant on board decoupling capacitance and is not a direct indication of the raw part performance.

[9] When Divider is bypassed, no termination loads and delay line disabled case.

**PROGRAMMABLE CLOCK DIVIDER AND DELAY
DC - 4 GHz**



TYPICAL PERFORMANCE CHARACTERISTICS

Unless otherwise specified: T = 27 °C, Regulated VDD = 3.3 V, 1.5 GHz, 6 dBm in, AC coupled single ended input and output, 120 Ω/leg DC termination, AC coupled into 50 Ω measuring load.

Figure 1. Phase Noise Performance vs Divider Ratio at 1.5 GHz Div 1/2/4/8/16

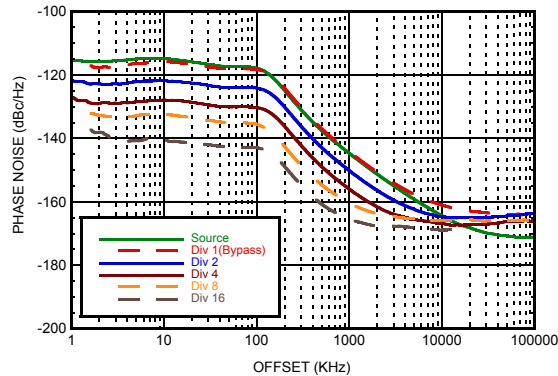

Figure 2. Phase Noise Performance vs Temperature at 1.5 GHz Div 2

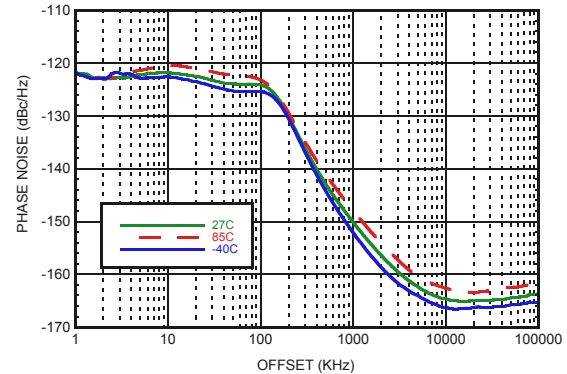

Figure 3. Phase Noise Floor Performance Vs Input Swing

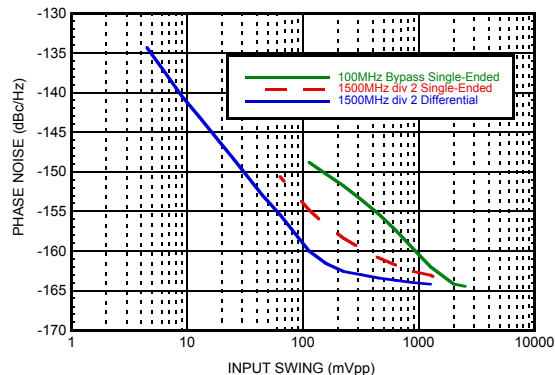

Figure 4. Phase Noise Floor Performance Vs Output Frequency [1]

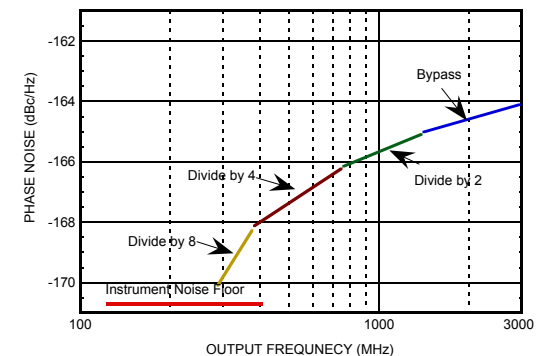

Figure 5. VOUT Vs Frequency over Temperature [2]

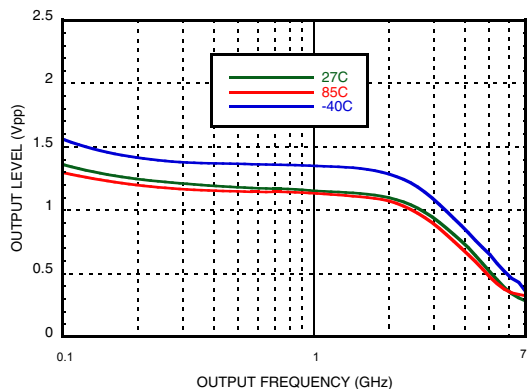
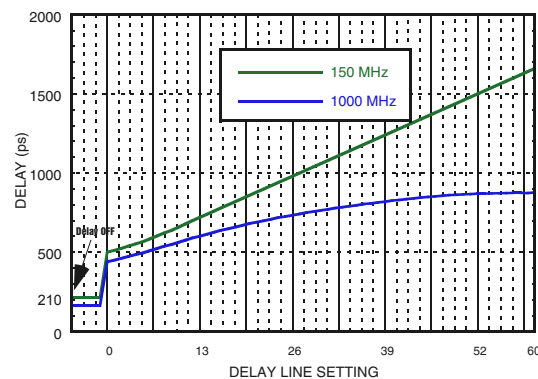

Figure 6. Delay Vs Delay line Setpoint [3]



[1] Measured Differential input and out at various frequencies. Under 300 MHz, the measurement is restricted by the instrument.

[2] Measured single-ended. 120 Ω DC termination, 3.3 V 1 +6 dBm single-ended input. HMC988LP3E AC coupled to 50 Ω instrument with divider bypass

[3] Corrected for board delay 210 ps

**PROGRAMMABLE CLOCK DIVIDER AND DELAY
DC - 4 GHz**



Figure 7. S-Parameters-S22 [4]

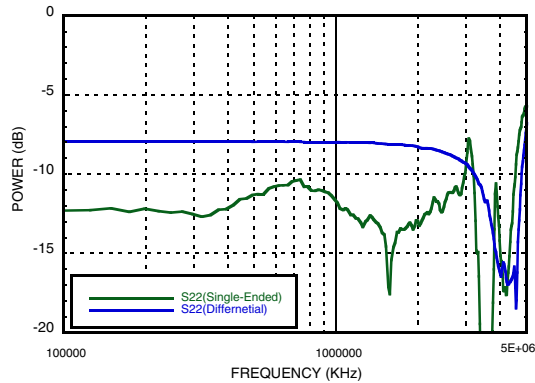

Figure 8. S-Parameters-S11 [4]

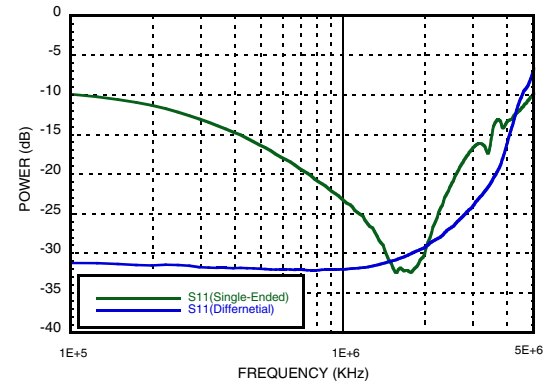

Figure 9. Input Sensitivity [5]

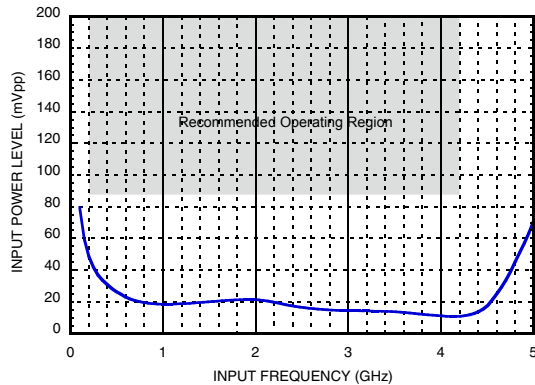

Figure 10. Supply Voltage vs input Voltage [6]

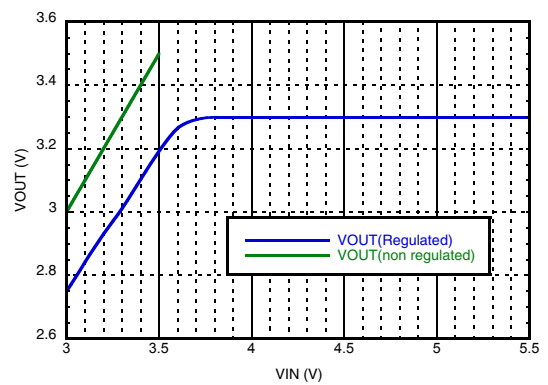
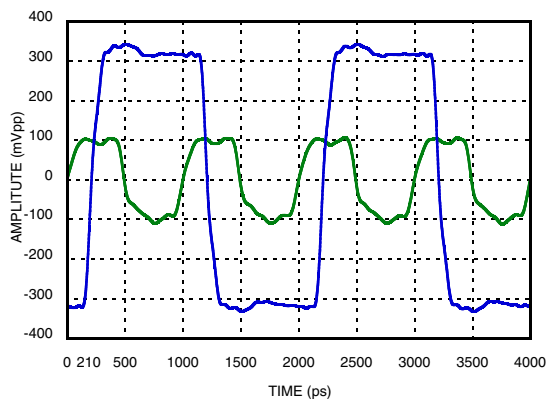

Figure 11. Time Domain 1 GHz input, 500 MHz Output [7]



[4] Measured with 200 Ω DC termination, 10 Ω series resistor in front, AC couple 1 nF 3.3 V

[5] Measured single-ended. 120 Ω DC termination, 3.3 V HMC988LP5E AC coupled to 50 Ω instrument(DSO8104B) with divider bypass. ESD diode will start to turn on if maximum input power exceeds 12 dBm.

[6] On Chip regulator enable mode measured at PIN CAP_3V Vs regulator bypass mode

[7] Measured with 1 GHz 400 mVpp source as single ended input, HMC988LP3E div 2. Board delay 210 ps

**PROGRAMMABLE CLOCK DIVIDER AND DELAY
DC - 4 GHz**

Table 2. Pin Descriptions

Pin Number	Function	Description
1,4,5	CHIP0, CHIP1, CHIP2	Chip SPI Address
2,3	OSCP, OSCN	Differential Signal Input
6	GPO	General Purpose Output Pin & Serial Data Out
7	SDI	Serial Data Input
8	SCK	Serial Data Clock
9	SLE	Serial Data Latch Enable
10,11	DIVN, DIVP	Differential Output Signal
12	VDD3_DECAP	Decoupling point for internally generated supply
13	TRIG	External SYNC or SLIP Control Pin for slip/synchronization start
14	FB_DECAP	Decoupling point for regulator
15	BGAP_DECAP	Decoupling point for regulator
16	VDD5	Regulator Input Supply Voltage

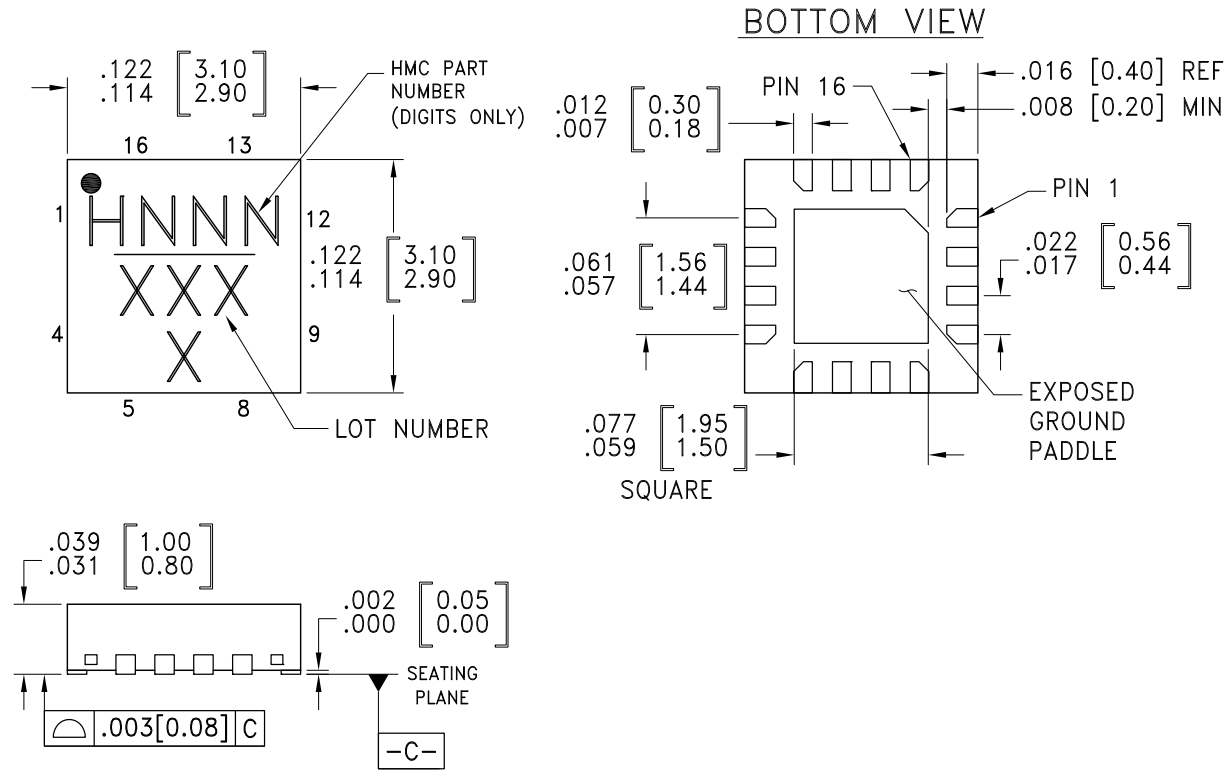

Table 3. Absolute Maximum Ratings

Parameter	Rating
Max Vdd to paddle on suply pin	-0.3 V to +5.5 V
OSCP, OSCN Max RF Power	13 dBm
OSCP, OSCN Differential DC	-0.3 V to 3.6 V
LVPECL Min Output Load Resistor	100 Ω to GND
LVPECL Output Load Current	40 mA/leg
Digital Load	1 k Ω min
Digital Input Voltage Range	-0.3 V to 3.6 V
Thermal Resistance (Jxn to Gnd Paddle)	25 $^{\circ}\text{C}/\text{W}$
Operating Temperature Range	-40 $^{\circ}\text{C}$ to +85 $^{\circ}\text{C}$
Storage Temperature Range	-65 $^{\circ}\text{C}$ to + 125 $^{\circ}\text{C}$
Maximum Junction Temperature	+125 $^{\circ}\text{C}$
Reflow Soldering	
Peak Temperature	260 $^{\circ}\text{C}$
Time at Peak Temperature	40 sec
ESD Sensitivity HBM	Class 1C

Stresses above those listed under Absolute Maximum Ratings may cause permanent damage to the device. This is a stress rating only; functional operation of the device at these or any other conditions above those indicated in the operational section of this specification is not implied. Exposure to absolute maximum rating conditions for extended periods may affect device reliability.



Outline Drawing



NOTES:

- [1] PACKAGE BODY MATERIAL: LOW STRESS INJECTION MOLDED PLASTIC SILICA AND SILICON IMPREGNATED.
- [2] LEAD AND GROUND PADDLE MATERIAL: COPPER ALLOY.
- [3] LEAD AND GROUND PADDLE PLATING: 100% MATTE TIN.
- [4] DIMENSIONS ARE IN INCHES [MILLIMETERS].
- [5] LEAD SPACING TOLERANCE IS NON-CUMULATIVE.
- [6] PAD BURR LENGTH SHALL BE 0.15 mm MAX. PAD BURR HEIGHT SHALL BE 0.05 mm MAX.
- [7] PACKAGE WARP SHALL NOT EXCEED 0.05 mm
- [8] ALL GROUND LEADS AND GROUND PADDLE MUST BE SOLDERED TO PCB RF GROUND.
- [9] REFER TO HITTITE APPLICATION NOTE FOR SUGGESTED PCB LAND PATTERN.

Table 4. Package Information

Part Number	Package Body Material	Lead Finish	MSL Rating	Package Marking ^[1]
HMC988LP3E	RoHS-compliant Low Stress Injection Molded Plastic	100% matte Sn	MSL1 ^[2]	H988 XXXX

[1] 4-Digit lot number XXXX

[2] Max peak reflow temperature of 260 °C



Evaluation PCB

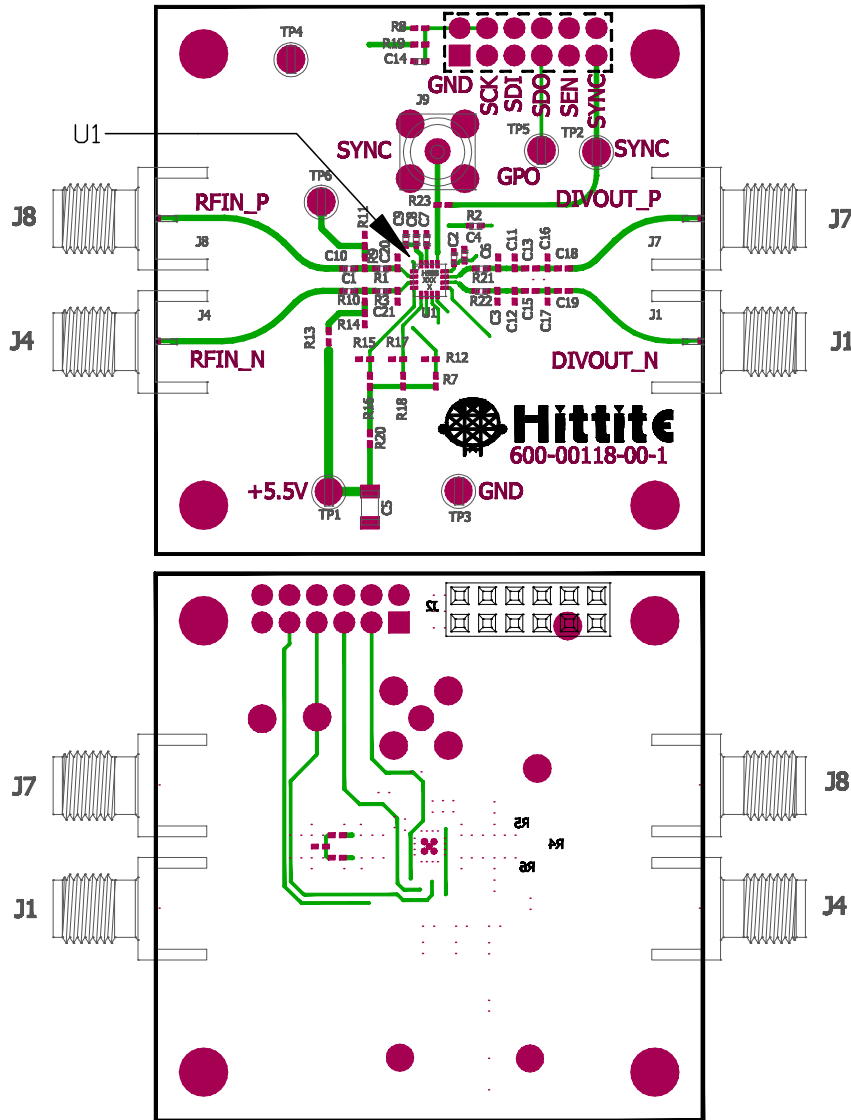

The circuit board used in the application should use RF circuit design techniques. Signal lines should have 50 Ω impedance while the package ground leads and exposed paddle should be connected directly to the ground plane similar to that shown. A sufficient number of via holes should be used to connect the top and bottom ground planes. The evaluation circuit board shown is available from Hittite upon request.

Evaluation PCB Schematic

To view this [Evaluation PCB Schematic](http://www.hittite.com) please visit www.hittite.com and choose HMC988LP3E from the "Search by Part Number" pull down menu to view the product splash page.

**PROGRAMMABLE CLOCK DIVIDER AND DELAY
DC - 4 GHz**

Table 5. Evaluation Order Information

Item	Contents	Part Number
Evaluation PCB Only	HMC988LP3E Evaluation PCB	EVAL01-HMC988LP3E
Evaluation Kit	HMC988LP3E Evaluation PCB USB Interface Board 6' USB A Male to USB B Female Cable CD ROM (Contains User Manual, Evaluation PCB Schematic, Evaluation Software, Hittite PLL Design Software)	EKIT01-HMC988LP3E



Theory of Operation

In addition to HMC988LP3E excellent low noise performance, the device offers additional functionality including:

- Modular Configuration
- Synchronization Function
- Adjustable Fine Delay
- Adjustable Coarse Delay
- Trigger Options
- Optional On-Chip Regulator
- GPO

Modular Configuration

The HMC988LP3E has been designed so that up to 8 devices can be placed on one SPI bus. The part has a 3-bit addressable chip addresses (CHIP0 pin, CHIP1 pin, CHIP2 pin) so that each chip can be controlled individually. In addition, HMC988LP3E has a broadcast mode which allows up to 8 HMC988LP3E devices to be simultaneously controlled, or triggered. In Broadcast mode each HMC988LP3E device will listen to the same chip address, namely "111." Typical application of HMC988LP3E is shown in [Figure 1](#).

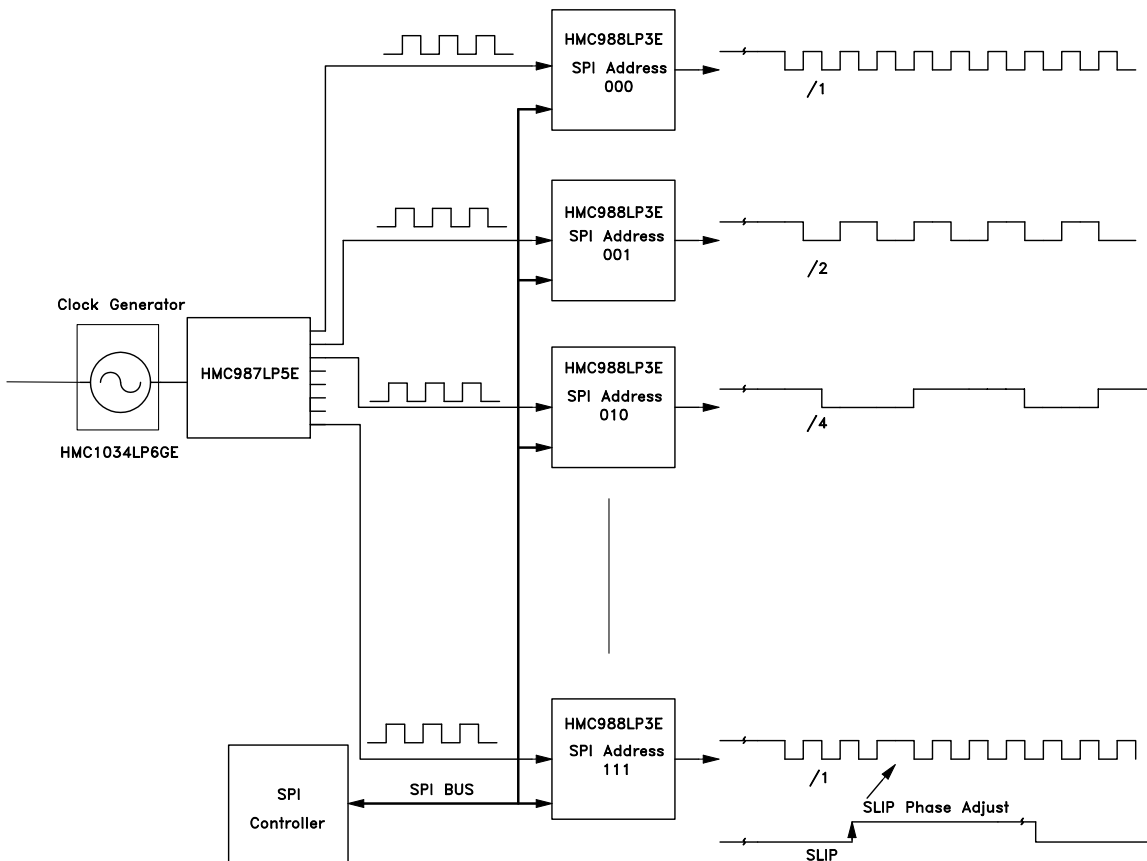

Figure 1. Typical application of HMC988LP3E



Although the HMC988LP3E has only 8 SPI chip addresses, one of which (“111”) is used in the broadcast mode, it is still possible to use broadcast mode and control 8 HMC988LP3E devices on one SPI bus, according to the following procedure:

Communicate with first 7 HMC988LP3E devices in a standard SPI mode. Select their chip addresses and write to the registers of interest.

1. After communicating with first 7 devices, with chip addresses ranging from (“000” to “110”), ensure that Broadcast Mode for all of them is disabled by writing to [Reg04h\[0\]](#) = “0” to each device.
2. Communicate with the 8th device, with Chip addresses (“111”) in standard mode. The rest of the devices will not be listening because their Broadcast Mode is disabled ([Reg04h\[0\]](#) = “0”).
3. If a broadcast to all devices on the SPI bus is required, Broadcast Mode needs to be enabled ([Reg04h\[0\]](#) = “1”) for each device separately. After the Broadcast Mode is enabled in each device, the SPI controller can write to the SPI bus in a standard way while selecting chip address (“111”). All of the HMC988LP3E devices will be listening.

Synchronization Function

If the HMC988LP3E is used in a typical application as shown in [Figure 1](#), it may be advantageous for some or all of the outputs to be synchronized. The HMC988LP3E can accomplish this using its SYNC functionality. The SYNC feature is limited to low frequency (100MHz maximum) input clocks due to the internal rise time and delay on the internal trigger signal path.

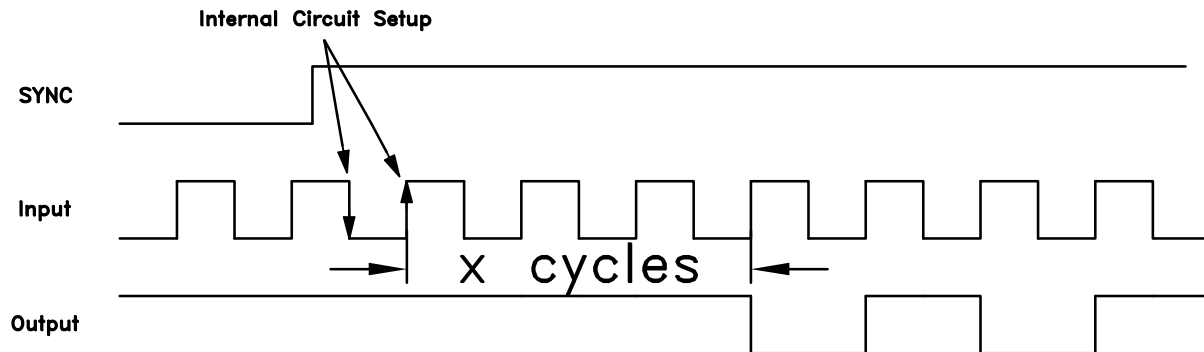

Figure 2. HMC988LP3E SYNC Function Timing Diagram

As shown in [Figure 2](#), the Sync function ensures that all outputs launch synchronously, a number of input cycles after the the SYNC function is triggered. The delay, measured in the number of input cycles, is governed by equation 1 where x is the number of input cycles and N is the divide ratio selection ([Reg02h\[2:0\]](#)) of HMC988LP3E.

$$x = \begin{cases} \text{NA: Output disabled} & \text{if } N = 1 \\ \left(\frac{N}{2}\right) + 1 & \text{if } N > 1 \text{ and } \text{Reg06h}[2]=0 \\ \left(\frac{N}{2}\right) + 2 & \text{if } N > 1 \text{ and } \text{Reg06h}[2]=1 \end{cases}$$



Adjustable Coarse Delay

The HMC988LP3E provides the option to delay the output one cycle of the input signal using its SLIP function. This function in essence prevents the input signal from cycling for 1 period and causes a corresponding phase shift in the output signal. Timing diagram of the execution of the Slip function is show in [Figure 3](#).

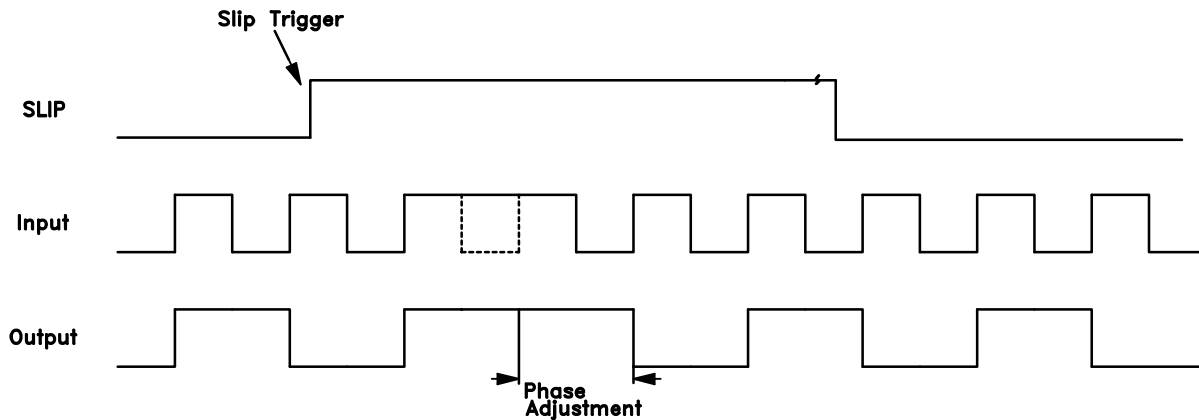

Figure 3. HMC988LP3E's SLIP Function Timing Diagram

In addition, the HMC988LP3E allows the user to select the launch phase of the output signal relative to the input signal by programming [Reg06h\[2\]](#). When this functionality is used in conjunction with the Slip function, it allows the user to adjust the delay/phase of the output signal, in increments of half period of the input signal. Example of a half period delay is shown in [Figure 4](#). In order to achieve the half period delay, the HMC988LP3E delays the output by one full period of the input signal, by using the SLIP function, then [Reg06h\[2\]](#) value is changed from "1" (rising edge) to "0" (falling edge) and the output is effectively sped up by half cycle of the input, resulting in a total delay of one half of the period of the input signal. Similar methodology can be deployed to delay the output signal by X.5 or more cycles, in effect the user would deploy the Slip function to X+1 times and then switch the trigger from rising edge to falling edge to achieve a total delay of X.5.

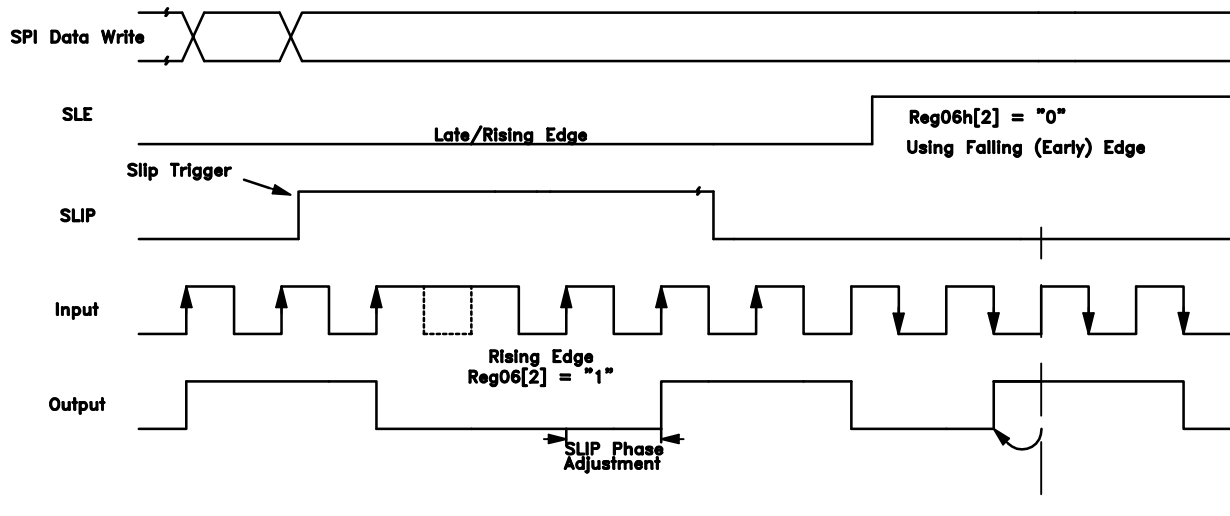

Figure 4. Delay by 1/2 of Input Clock Cycle Timing Diagram

Adjustable Fine Delay

In addition to the 1/2 cycle delay offered by the slip function, the output of the HMC988LP3E can be delayed in ~20 ps steps, by programming [Reg07h\[5:0\]](#), anywhere from 0 to 60. The delay function follows Equation 2.

$$\text{Delay} \cong (\text{Reg07h}) \times 20\text{ps} + 300\text{ps} \quad \text{EQ (2)}$$

At higher frequencies (> 200 MHz), the step size compresses near the high end of the range when using the Fine Delay. See [Figure 6](#). If Fine Delay is used when the divider is bypassed (divide-by-1) the maximum frequency is limited to 650MHz. As the frequency is increased beyond 650MHz the output amplitude will decrease when the divider is bypassed.

Please note that the phase noise can degrade by 15 dB when using Fine Delay mode.

Trigger Details

In HMC988LP3E, the Sync and the Slip functions can both be implemented using the external "TRIG" pin or by using the SPI interface. The circuit diagram for SYNC and SLIP controls pins is shown in Figure 5. Note that the SYNC and SLIP should not be applied at the same time.

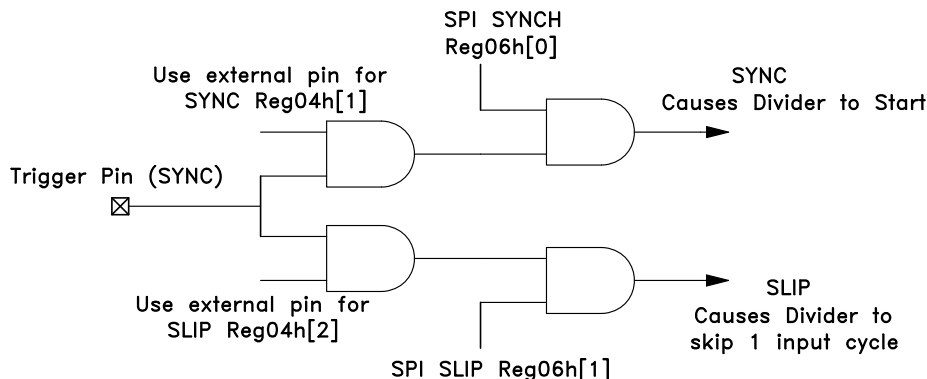

Figure 5. SYNC/SLIP Circuit Diagram



Executing SYNC/SLIP Using External Pin

In order to execute SYNC or SLIP function using the external pin, simply assert the external “TRIG” pin of the HMC988LP3E. The functions will trigger on the rising edge of the external SYNC or SLIP pin. Note that the corresponding SYNC or SLIP external trigger awareness function needs to be enabled in the HMC988LP3E.

Note that [Reg04h\[1\]](#) and [Reg04h\[2\]](#) should never be equal to “1” at the same time. If “1” is written to [Reg04h\[1\]](#), then “0” needs to be written to [Reg04h\[2\]](#), and vice-versa.

Execute SYNC/SLIP Using the SPI Interface

Pin 9, Serial Latch Enable (SLE), of the HMC988LP3E causes SPI bits to change states and therefore acts as a trigger if the SYNC and SLIP functions are chosen to be executed using the SPI interface. Note that the SYNC signal is level sensitive, and must remain 1 in order to keep the internal divider running. The slip signal is rising-edge sensitive, and must be returned low at some point before the next trigger.

Optional On-Chip Regulator

The HMC988LP3E has an optional on-chip regulator that can be used or bypassed. The regulator requires an input voltage ≥ 3.8 V. The on-chip regulator circuit is shown in [Figure 6](#). The regulator can be bypassed by programming [Reg04h\[5\]](#) = “1”. In that case identical voltage should be applied to input of the regulator (VDD5) and VDD3_DECAP.

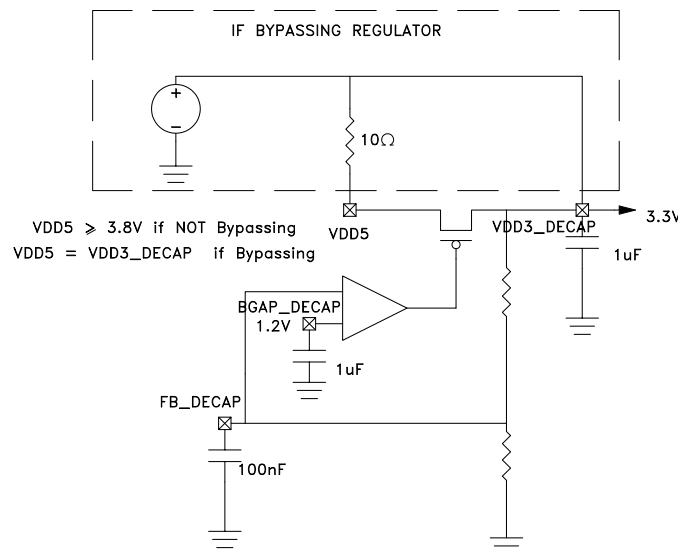

Figure 6. Regulator Circuit Diagram

GPO

The HMC988LP3E has a GPO (General Purpose Output) pin that can be used for obtaining various internal states of the device (many of which are only used for internal testing), or as an SPI output. The function of the GPO pin is configured in [Reg05h](#).



HMC988LP3E Input Stage

The HMC988LP3E input stage, [Figure 7](#), is flexible. It can be driven single-ended or differential, with LVPECL, LVDS, or CML signals. If driven single-ended, a large AC coupling cap to ground should be used on the undriven input. The input impedance is 50 Ω single-ended (100 Ω differential). The DC bias level of 2.0 V can be generated internally by programming [Reg04h\[3\]](#) = 1, supplied externally, or generated via an LVPECL termination network inside the part. When [Reg04h\[3\]](#) = 0 internal DC bias is disabled and LVPECL termination enabled.

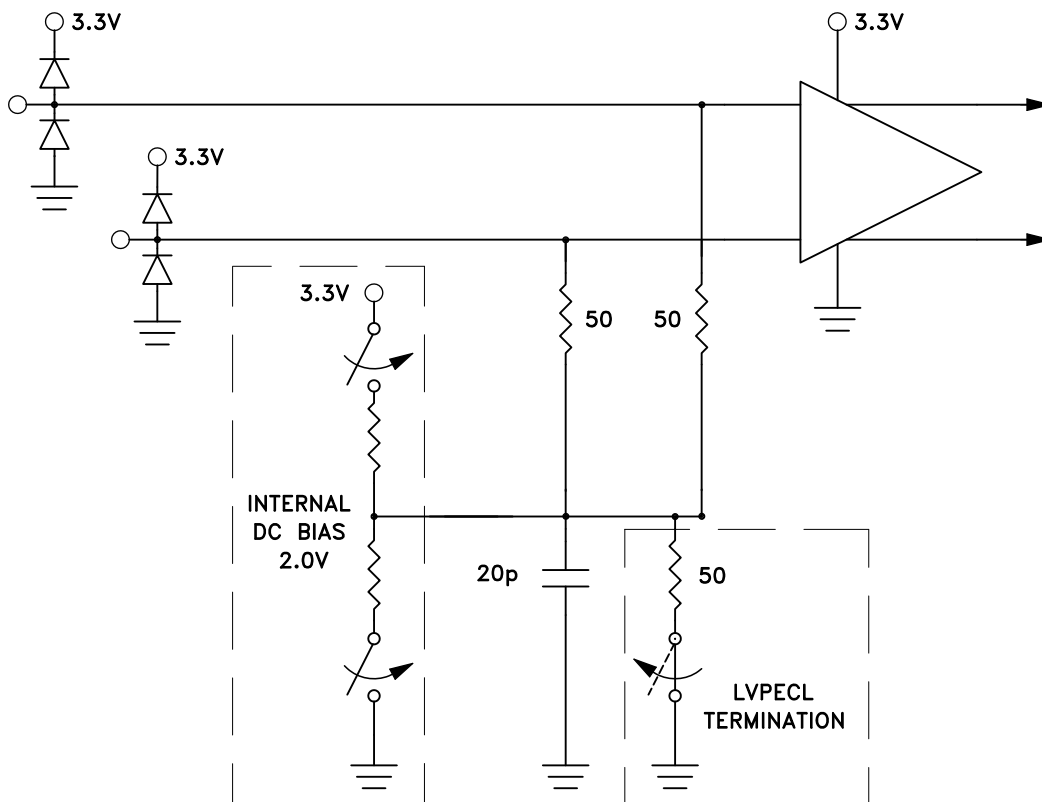

Figure 7. HMC988LP3E Input Stage

HMC988LP3E Output Stage

The LVPECL output driver produces up to 1.6 Vppd swing into 50 Ω loads. LVPECL drivers are terminated with off-chip resistors that provide the DC current through the emitter-follower output stage. The output stage has a switch which disconnects the output driver from the load when not used. The switch series resistor significantly improves the output match when driving into 50 Ω transmission lines. The switch series resistor causes a small DC level shift and swing degradation, depending on the termination current.

If unused, disabled LVPECL outputs can be left floating, terminated, or grounded.

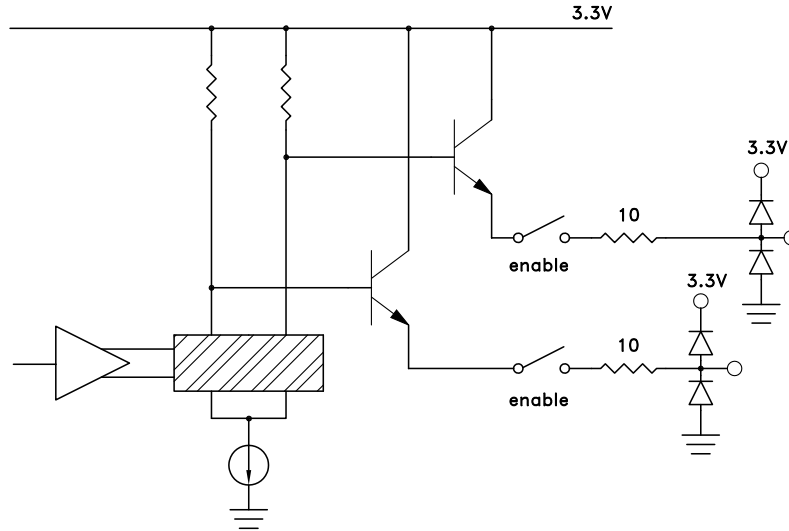

Figure 8. HMC988LP3E Output Stage

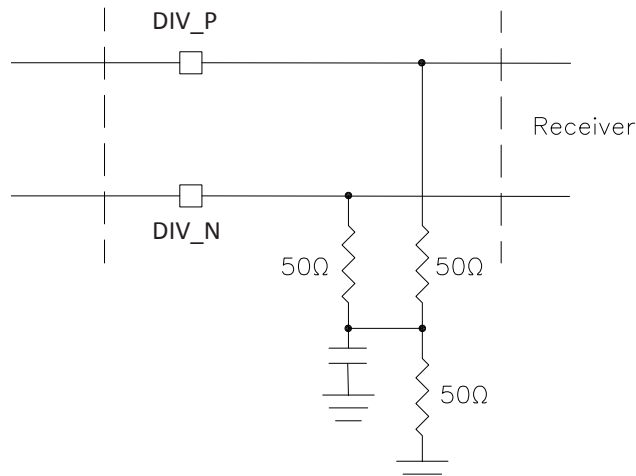

Figure 9. Typical LVPECL Termination



Serial Port Write Operation

Parameter	Conditions	Min.	Typ.	Max.	Units
t ₁	SDI setup time	3			ns
t ₂	SDI hold time	3			ns
t ₃	SLE low duration	10			ns
t ₄	SLE high duration	10			ns
t ₅	SCLK 9 Rising Edge to SLE Rising Edge	10			ns
	Serial port Clock Speed	DC	50		MHz
t ₆	SLE to SCLK Recovery Time	10			ns

A typical WRITE cycle is shown in [Figure 10](#).

- The Master (host) places 9 bit data, d8:d0, MSB first, on SDI on the first 9 falling edges of SCLK.
- The slave () shifts in data on SDI on the first 9 rising edges of SCLK
- Master places 4 bit register address to be written to, r3:r0, MSB first, on the next 4 falling edges of SCLK (10-13)
- Slave shifts the register address bits on the next 4 rising edges of SCLK (10-13).
- Master places 3 bit chip address, a2:a0, MSB first, on the next 3 falling edges of SCLK (14-16).
- Slave shifts the chip address bits on the 3 rising edges of SCLK (14-16).
- Master asserts SLE after the 16th rising edge of SCLK.
- Slave registers the SDI data on the rising edge of SLE.

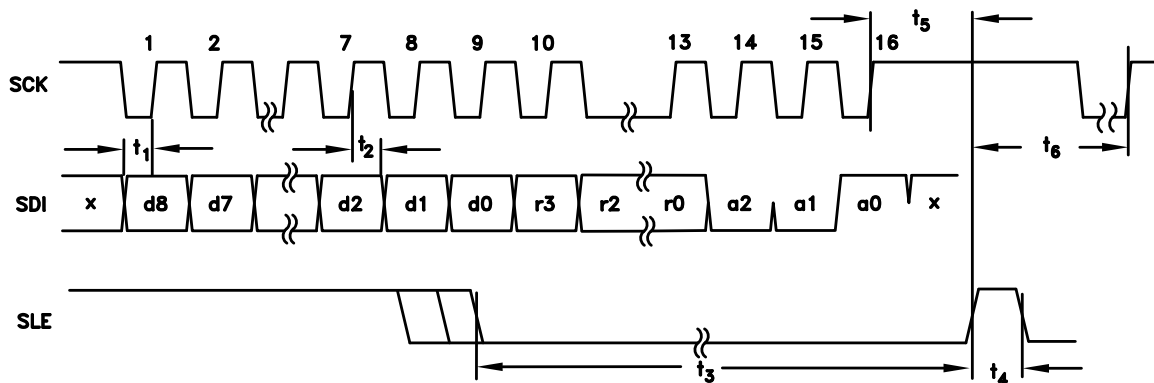

Figure 10. SPI Timing Diagram, Write Operation

Serial Port Read Operation

A typical READ cycle is shown in [Figure 11](#). In general, SDO line is always active during the WRITE cycle. SDO will contain the data from the addresses pointed to by [Reg00h](#). If [Reg00h](#) is not changed, the same data will always be present on the SDO. If it is desired to READ from a specific address, it is necessary in the first SPI cycle to write the desired address to [Reg00h](#), then in the next SPI cycle the desired data will be available on the SDO.

An example of the two cycle procedure to read from any random address is as follows:

PROGRAMMABLE CLOCK DIVIDER AND DELAY DC - 4 GHz



The Master (host), on the first 9 falling edges of SCLK places 9 bit data, d8:d0, MSB first, on SDI as shown in [Figure 11](#). d8:d0 should be set to zero. d3:d0 = address of the register to be READ on the next cycle.

- a. The slave () shifts in data on SDI on the first 9 rising edges of SCLK
- b. Master places 4 bit register address , r3:r0, (the address the WRITE ADDRESS register), MSB first, on the next 4 falling edges of SCLK (10-13). r3:r0=0000.
- c. Slave shifts the register bits on the next 4 rising edges of SCLK (10-13).
- d. Master places 3 bit chip address, a2:a0, MSB first, on the next 3 falling edges of SCLK (14-16).
- e. Slave shifts the chip address bits on the next 3 rising edges of SCLK (14-16).
- f. Master asserts SLE after the 16th rising edge of SCLK.
- g. Slave registers the SDI data on the rising edge of SLE.
- h. Master clears SLE to complete the address transfer of the two part READ cycle.
- i. If we do not wish to write data to the chip at the same time as we do the second cycle , then it is recommended to simply rewrite the same contents on SDI to Register zero on the READ back part of the cycle.
- j. Master places the same SDI data as the previous cycle on the next 16 falling edges of SCLK.
- k. Slave () shifts the SDI data on the next 16 rising edges of SCLK.
- l. Slave places the desired data (i.e. data from address in [Reg00h\[3:0\]](#)) on SDO on the next 16 rising edges of SCLK.
- m. Master asserts SLE after the 16th rising edge of SCLK to complete the cycle.

Note that if the chip address bits are unrecognized (a2:a0), the slave will tri-state the SDO output to prevent a possible bus contention issue.

Table 7. SPI Open Mode - Read Timing Characteristics

Parameter	Conditions	Min.	Typ.	Max.	Units
t ₁	SDI setup time	3			ns
t ₂	SDI hold time	3			ns
t ₃	SLE low duration	10			ns
t ₄	SLE high duration	10			ns
t ₅	SCLK Rising Edge to SDO time		8.2+0.2ns/ pF		ns
t ₆	SLE to SCLK Recovery Time	10			ns
t ₇	SCLK 16 Rising Edge to SLE Rising Edge	10			ns

**PROGRAMMABLE CLOCK DIVIDER AND DELAY
DC - 4 GHz**

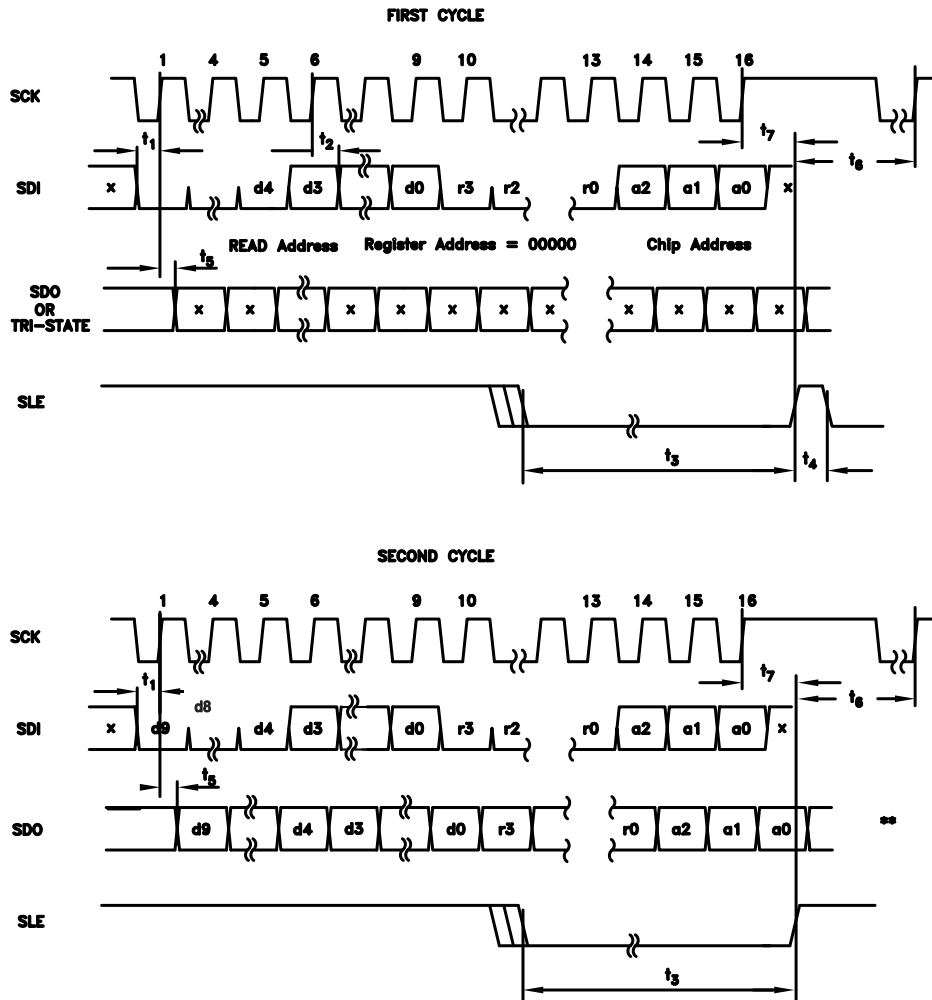

Figure 11. SPI Diagram, Read Operation 2- Cycles



Register Map

Table 8. Reg 00h - ID and Read Register

Bit	Name	Width	Default	Description
[3:0]	Read Control	4		Enter Register Address to be Read From
[4]	Soft Reset	1	0	1: Reset
[8:0]	Chip ID	9		Register 00 Contains the Chip ID (406 decimal)

Table 9. Reg 01h - Enables

Bit	Name	Width	Default	Description
[0]	Master Chip Enable	1	1	1 Enables the Chip
[1]	Rx Buffer Enable	1	1	1 Enables the Rx Buffer
[2]	Divider Core Enable	1	1	1 Enables the Divider Core
[3]	Output buffer enable	1	1	1 Enables the Output Buffer
[8:4]	Reserved	5	0	

Table 10. Reg 02h - Divide/Delay select

Bit	Name	Width	Default	Description
[2:0]	Divide Ratio Select	2	2	0: /1 1: /2 2: /4 3: /8 4: /16 5: /32 6: N/A 7: N/A
[8:3]	Reserved	6	0	

Table 11. Reg 03h - Bias

Bit	Name	Width	Default	Description
[1:0]	Reserved	2	2	
[3:2]	Reserved	2	2	
[5:4]	Transmit Buffer Swing Select	2	2	0: 600mVpp Single Ended 1: 700mVpp Single Ended 2: 800mVpp Single Ended 3: 900mVpp Single Ended
[8:6]	SYNC Delay Adjustment	3	3	Can be used to equalize SYNC delay between dividers. $1000+(0-7)*80$ ps



Table 12. Reg 04h - Configuration

Bit	Name	Width	Default	Description
[0]	Broadcast Mode	1	0	if 1, a write to Chip Addr "111" will be listened to by all slaves. Useful for synchronizing multiple dividers
[1]	External SYNC Pin EN	1	1	External pin can be used to start-up divider synchronously.
[2]	External SLIP Pin EN	1	0	External pin can be used to slip divider synchronously Both ExtSLIP and ExtSYNC bits should not be '1' at the same time
[3]	RX Buffer DC Bias Select	1	0	Use 1 for sinusoidal / non-LVPECL AC coupled inputs
[4]	Delay Line Enable	1	0	Use 0 for natural low-noise path, 1 enables the fine delay
[5]	On-Chip Regulator Bypass	1	0	1 bypass the on-chip regulator, 0 enable the on-chip regulator
[8:6]	Reserved	3	0	

Table 13. Reg 05h - General Purpose Output

Bit	Name	Width	Default	Description
[2:0]	GPO Select	2	0	0: 0 1: 1 2: slip req 3: 0 4: sync req 5: sync delayed 6: waiting for clock pulse (post sync) 7: spare
[3]	Force GPO Pin on GPO only	1	0	no automux to serial data output
[4]	Force GPO Pin on SDO only	1	0	no automux to GPO selected data PRIORITY
[5]	Force GPO Pin to HiZ	1	0	Force GPO pin to HiZ
[8:6]	Reserved	3	0	

Table 14. Reg 06h - SPI Triggers

Bit	Name	Width	Default	Description
[0]	SPI SYNC Signal	1	1	0 - holds divider in reset, 1 allows startup
[1]	SPI SLIP Signal	1	0	A 0 to 1 level change is sensed by the input clock, and causes a full input cycle-slip. The signal must be maintained for > 4 T _{vco} input clock cycles before brought low.
[2]	Output Launch Phase	1	0	0: Falling Edge (Early) 1: Rising Edge (Late) To delay the output by 1/2 cycle you can switch from early to late. To go back, you must force N-1 full cycle slips, and switch back from late to early.
[8:3]	Reserved	6	0	

Table 15. Reg 07 - Delay Lines

Bit	Name	Width	Default	Description
[5:0]	Delay Line Setpoint	6	4	Delay = Setpoint * 20 ps + 300 ps (Max of 300 -> 1500 ps)
[8:6]	Reserved	3	0	

X-ON Electronics

Largest Supplier of Electrical and Electronic Components

Click to view similar products for [RF Development Tools](#) category:

Click to view products by [Analog Devices](#) manufacturer:

Other Similar products are found below :

[MAAM-011117](#) [MAAP-015036-DIEEV2](#) [EV1HMC1113LP5](#) [EV1HMC6146BLC5A](#) [EV1HMC637ALP5](#) [EVAL-ADG919EBZ](#) [ADL5363-EVALZ](#) [LMV228SDEVAL](#) [SKYA21001-EVB](#) [SMP1331-085-EVB](#) [EV1HMC618ALP3](#) [EVAL01-HMC1041LC4](#) [MAAL-011111-000SMB](#)
[MAAM-009633-001SMB](#) [MASW-000936-001SMB](#) [107712-HMC369LP3](#) [107780-HMC322ALP4](#) [SP000416870](#) [EV1HMC470ALP3](#)
[EV1HMC520ALC4](#) [EV1HMC244AG16](#) [MAX2614EVKIT#](#) [124694-HMC742ALP5](#) [SC20ASATEA-8GB-STD](#) [MAX2837EVKIT+](#)
[MAX2612EVKIT#](#) [MAX2692EVKIT#](#) [EV1HMC629ALP4E](#) [SKY12343-364LF-EVB](#) [108703-HMC452QS16G](#) [EV1HMC863ALC4](#)
[EV1HMC427ALP3E](#) [119197-HMC658LP2](#) [EV1HMC647ALP6](#) [ADL5725-EVALZ](#) [106815-HMC441LM1](#) [EV1HMC1018ALP4](#)
[UXN14M9PE](#) [MAX2016EVKIT](#) [EV1HMC939ALP4](#) [MAX2410EVKIT](#) [MAX2204EVKIT+](#) [EV1HMC8073LP3D](#) [SIMSA868-DKL](#)
[SIMSA868C-DKL](#) [SKY65806-636EK1](#) [SKY68020-11EK1](#) [SKY67159-396EK1](#) [SKY66181-11-EK1](#) [SKY65804-696EK1](#)